

**MINNESOTA DEPARTMENT OF TRANSPORTATION**  
**TRAFFIC DATA COLLECTION - Metro**

Location: Hopkins Xrd and Fairfield Rd File Name : TMC\_#18 Hopkins Xrd & Fairfield Rd\_20181002  
 Data Prepared By: ACS Site Code :  
 TURNING MOVEMENT COUNT Start Date : 10/2/2018  
 Page No : 1

Groups Printed- Cars - Trucks

Start Time	Southbound				Westbound				Northbound				Eastbound				Int. Total
	Left	Thru	Right	Peds	Left	Thru	Right	Peds	Left	Thru	Right	Peds	Left	Thru	Right	Peds	
06:00	2	12	1	0	1	0	1	0	3	8	4	1	0	0	2	0	35
06:15	5	24	1	0	2	0	0	0	1	19	5	0	0	0	5	0	62
06:30	5	30	2	0	6	0	1	0	0	16	10	0	1	0	3	0	74
06:45	7	40	2	2	6	0	1	0	1	28	10	0	2	0	7	0	106
Total	19	106	6	2	15	0	3	0	5	71	29	1	3	0	17	0	277
07:00	13	61	2	0	12	1	2	0	1	32	10	0	4	2	11	0	151
07:15	12	91	6	1	9	0	0	0	1	43	15	1	3	0	7	1	190
07:30	18	108	6	0	9	1	2	0	4	52	28	0	0	0	12	0	240
07:45	30	106	7	0	8	2	0	1	8	46	24	1	1	1	11	0	246
Total	73	366	21	1	38	4	4	1	14	173	77	2	8	3	41	1	827
08:00	30	137	4	1	9	0	2	0	7	59	43	0	6	1	13	0	312
08:15	20	186	7	0	8	1	1	0	4	40	26	0	1	1	6	0	301
08:30	19	155	5	0	6	2	2	1	3	41	32	0	1	2	17	1	287
08:45	23	110	10	1	9	2	2	0	11	36	18	1	3	2	9	1	238
Total	92	588	26	2	32	5	7	1	25	176	119	1	11	6	45	2	1138
*** BREAK ***																	
11:00	3	44	1	1	6	2	2	0	11	34	8	0	7	0	10	0	129
11:15	2	34	6	0	10	0	6	0	12	48	6	4	6	0	10	0	144
11:30	1	49	5	0	22	1	6	1	18	40	6	1	6	0	18	0	174
11:45	4	42	11	0	10	4	8	0	34	42	11	3	3	0	8	0	180
Total	10	169	23	1	48	7	22	1	75	164	31	8	22	0	46	0	627
12:00	6	47	3	4	13	0	5	0	12	44	11	4	10	1	19	1	180
12:15	5	57	9	0	8	4	6	0	8	47	11	1	4	0	9	3	172
12:30	7	56	8	0	6	3	3	0	9	53	10	4	1	2	9	2	173
12:45	7	44	10	1	6	3	4	1	11	49	16	3	3	1	7	3	169
Total	25	204	30	5	33	10	18	1	40	193	48	12	18	4	44	9	694
*** BREAK ***																	
15:00	2	39	2	0	8	1	5	0	6	74	6	0	2	1	6	0	152
15:15	1	36	5	0	6	2	8	0	9	56	4	0	5	0	5	0	137
15:30	1	27	4	0	7	2	12	1	20	69	6	1	7	1	8	0	166
15:45	2	43	6	1	10	2	3	0	19	90	5	0	5	2	9	0	197
Total	6	145	17	1	31	7	28	1	54	289	21	1	19	4	28	0	652
16:00	1	60	9	1	20	2	23	0	11	111	6	0	2	2	8	3	259
16:15	0	69	7	0	21	1	16	0	10	132	7	1	7	1	6	1	279
16:30	2	76	5	0	21	6	11	0	12	102	3	1	6	3	7	1	256
16:45	2	76	7	0	17	3	16	1	6	104	7	0	2	1	11	0	253
Total	5	281	28	1	79	12	66	1	39	449	23	2	17	7	32	5	1047
17:00	0	76	4	0	24	11	19	0	10	121	9	0	4	1	11	1	291
17:15	1	98	6	0	14	5	22	0	10	122	7	0	4	1	10	1	301

**MINNESOTA DEPARTMENT OF TRANSPORTATION**  
**TRAFFIC DATA COLLECTION - Metro**

Location: Hopkins Xrd and Fairfield Rd File Name : TMC\_#18 Hopkins Xrd & Fairfield Rd\_20181002  
 Data Prepared By: ACS Site Code :  
 TURNING MOVEMENT COUNT Start Date : 10/2/2018  
 Page No : 2

Groups Printed- Cars - Trucks

Start Time	Southbound				Westbound				Northbound				Eastbound				Int. Total
	Left	Thru	Right	Peds	Left	Thru	Right	Peds	Left	Thru	Right	Peds	Left	Thru	Right	Peds	
17:30	0	80	9	1	10	2	12	0	16	95	7	1	3	5	7	2	250
17:45	0	58	5	2	17	2	13	0	19	83	10	0	9	0	9	1	228
Total	1	312	24	3	65	20	66	0	55	421	33	1	20	7	37	5	1070
Grand Total	231	2171	175	16	341	65	214	6	307	1936	381	28	118	31	290	22	6332
Apprch %	8.9	83.7	6.7	0.6	54.5	10.4	34.2	1	11.6	73	14.4	1.1	25.6	6.7	62.9	4.8	
Total %	3.6	34.3	2.8	0.3	5.4	1	3.4	0.1	4.8	30.6	6	0.4	1.9	0.5	4.6	0.3	
Cars	228	2110	167	16	325	63	213	6	289	1874	375	28	114	29	264	22	6123
% Cars	98.7	97.2	95.4	100	95.3	96.9	99.5	100	94.1	96.8	98.4	100	96.6	93.5	91	100	96.7
Trucks	3	61	8	0	16	2	1	0	18	62	6	0	4	2	26	0	209
% Trucks	1.3	2.8	4.6	0	4.7	3.1	0.5	0	5.9	3.2	1.6	0	3.4	6.5	9	0	3.3

# MINNESOTA DEPARTMENT OF TRANSPORTATION

## TRAFFIC DATA COLLECTION - Metro

Location: Hopkins Xrd and Fairfield Rd    File Name : TMC\_#18 Hopkins Xrd & Fairfield Rd\_20181002  
 Data Prepared By: ACS    Site Code :  
 TURNING MOVEMENT COUNT    Start Date : 10/2/2018  
 Page No : 3

Start Time	Southbound					Westbound					Northbound					Eastbound					Int. Total
	Left	Thru	Right	Peds	App. Total	Left	Thru	Right	Peds	App. Total	Left	Thru	Right	Peds	App. Total	Left	Thru	Right	Peds	App. Total	
Peak Hour Analysis From 06:00 to 08:45 - Peak 1 of 1																					
Peak Hour for Entire Intersection Begins at 07:45																					
07:45	30	106	7	0	143	8	2	0	1	11	8	46	24	1	79	1	1	11	0	13	246
08:00	30	137	4	1	172	9	0	2	0	11	7	59	43	0	109	6	1	13	0	20	312
08:15	20	186	7	0	213	8	1	1	0	10	4	40	26	0	70	1	1	6	0	8	301
08:30	19	155	5	0	179	6	2	2	1	11	3	41	32	0	76	1	2	17	1	21	287
Total Volume	99	584	23	1	707	31	5	5	2	43	22	186	125	1	334	9	5	47	1	62	1146
% App. Total	14	82.6	3.3	0.1		72.1	11.6	11.6	4.7		6.6	55.7	37.4	0.3		14.5	8.1	75.8	1.6		
PHF	.825	.785	.821	.250	.830	.861	.625	.625	.500	.977	.688	.788	.727	.250	.766	.375	.625	.691	.250	.738	.918

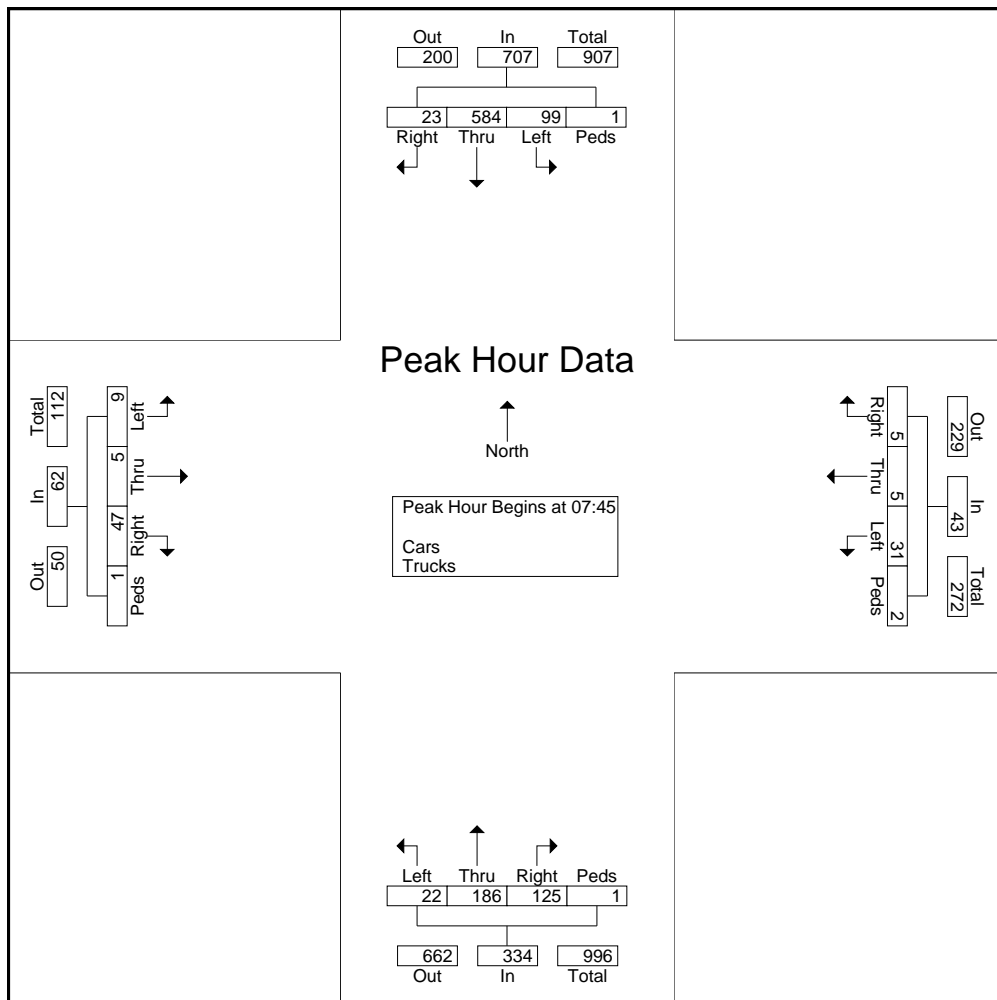

# MINNESOTA DEPARTMENT OF TRANSPORTATION

## TRAFFIC DATA COLLECTION - Metro

Location: Hopkins Xrd and Fairfield Rd    File Name : TMC\_#18 Hopkins Xrd & Fairfield Rd\_20181002  
 Data Prepared By: ACS    Site Code :  
 TURNING MOVEMENT COUNT    Start Date : 10/2/2018  
 Page No : 4

Start Time	Southbound					Westbound					Northbound					Eastbound					Int. Total
	Left	Thru	Right	Peds	App. Total	Left	Thru	Right	Peds	App. Total	Left	Thru	Right	Peds	App. Total	Left	Thru	Right	Peds	App. Total	
Peak Hour Analysis From 11:00 to 12:45 - Peak 1 of 1																					
Peak Hour for Entire Intersection Begins at 11:30																					
11:30	1	49	5	0	55	22	1	6	1	30	18	40	6	1	65	6	0	18	0	24	174
11:45	4	42	11	0	57	10	4	8	0	22	34	42	11	3	90	3	0	8	0	11	180
12:00	6	47	3	4	60	13	0	5	0	18	12	44	11	4	71	10	1	19	1	31	180
12:15	5	57	9	0	71	8	4	6	0	18	8	47	11	1	67	4	0	9	3	16	172
Total Volume	16	195	28	4	243	53	9	25	1	88	72	173	39	9	293	23	1	54	4	82	706
% App. Total	6.6	80.2	11.5	1.6		60.2	10.2	28.4	1.1		24.6	59	13.3	3.1		28	1.2	65.9	4.9		
PHF	.667	.855	.636	.250	.856	.602	.563	.781	.250	.733	.529	.920	.886	.563	.814	.575	.250	.711	.333	.661	.981

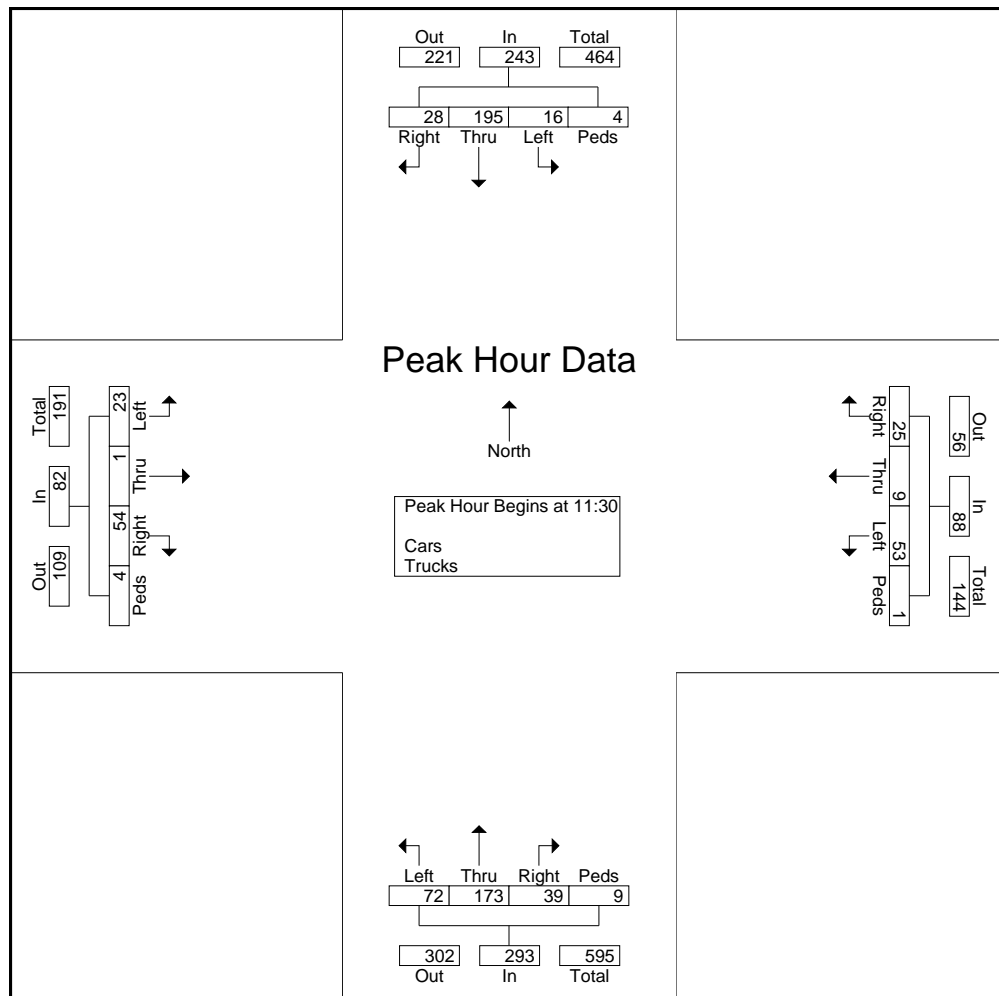

# MINNESOTA DEPARTMENT OF TRANSPORTATION

## TRAFFIC DATA COLLECTION - Metro

Location: Hopkins Xrd and Fairfield Rd    File Name : TMC\_#18 Hopkins Xrd & Fairfield Rd\_20181002  
 Data Prepared By: ACS    Site Code :  
 TURNING MOVEMENT COUNT    Start Date : 10/2/2018  
 Page No : 5

Start Time	Southbound					Westbound					Northbound					Eastbound					Int. Total
	Left	Thru	Right	Peds	App. Total	Left	Thru	Right	Peds	App. Total	Left	Thru	Right	Peds	App. Total	Left	Thru	Right	Peds	App. Total	
Peak Hour Analysis From 15:00 to 17:45 - Peak 1 of 1																					
Peak Hour for Entire Intersection Begins at 16:30																					
16:30	2	76	5	0	83	21	6	11	0	38	12	102	3	1	118	6	3	7	1	17	256
16:45	2	76	7	0	85	17	3	16	1	37	6	104	7	0	117	2	1	11	0	14	253
17:00	0	76	4	0	80	24	11	19	0	54	10	121	9	0	140	4	1	11	1	17	291
17:15	1	98	6	0	105	14	5	22	0	41	10	122	7	0	139	4	1	10	1	16	301
Total Volume	5	326	22	0	353	76	25	68	1	170	38	449	26	1	514	16	6	39	3	64	1101
% App. Total	1.4	92.4	6.2	0		44.7	14.7	40	0.6		7.4	87.4	5.1	0.2		25	9.4	60.9	4.7		
PHF	.625	.832	.786	.000	.840	.792	.568	.773	.250	.787	.792	.920	.722	.250	.918	.667	.500	.886	.750	.941	.914

