



Minnesota Dept. of Transportation

Traffic Data Collection -Metro

694-94 N RAMP AT SHINGLE CREEK PKWY
 Ref.Pt; 223.650 NORTH RAMP
 Jamar # T-2638 CAH
 TURN MOVEMENT COUNT

File Name : 694-94 N RAMP AT SHINGLE CREEK PKWY
 Site Code : 223.650
 Start Date : 11/7/2012
 Page No : 1

Groups Printed- Unshifted

Start Time	SHINGLE CREEK PKWY Southbound				694 / 94 North Ramp Westbound				SHINGLE CREEK PKWY Northbound				694 / 94 North Ramp Eastbound				Int. Total
	Right	Thru	Left	Peds	Right	Thru	Left	Peds	Right	Thru	Left	Peds	Right	Thru	Left	Peds	
06:00	26	41	0	0	0	0	0	0	0	28	5	0	3	0	48	0	151
06:15	37	35	0	0	0	0	0	0	0	32	2	0	9	0	27	0	142
06:30	33	49	0	0	0	0	0	0	0	28	10	0	16	0	62	0	198
06:45	31	54	0	0	0	0	0	0	0	57	13	0	51	0	53	0	259
Total	127	179	0	0	0	0	0	0	0	145	30	0	79	0	190	0	750
07:00	45	70	0	1	0	0	0	0	0	58	11	0	34	0	57	0	276
07:15	43	77	0	0	0	0	0	0	0	60	16	0	43	0	61	0	300
07:30	59	72	0	0	0	0	0	0	0	64	18	0	52	0	80	0	345
07:45	33	95	0	0	0	0	0	0	0	75	17	0	40	0	85	1	346
Total	180	314	0	1	0	0	0	0	0	257	62	0	169	0	283	1	1267
08:00	39	72	0	0	0	0	0	0	0	59	18	0	55	0	86	0	329
08:15	30	75	0	0	0	0	0	0	0	66	20	0	48	0	57	0	296
08:30	22	63	0	0	0	0	0	0	0	42	16	0	35	0	63	0	241
08:45	45	75	0	0	0	0	0	0	0	59	18	0	39	0	79	0	315
Total	136	285	0	0	0	0	0	0	0	226	72	0	177	0	285	0	1181
*** BREAK ***																	
15:00	62	111	0	0	0	0	0	0	0	86	43	0	33	0	46	0	381
15:15	62	107	0	0	0	0	0	0	0	89	46	0	48	0	54	0	406
15:30	68	120	0	1	0	0	0	0	0	79	46	0	36	0	55	0	405
15:45	62	102	0	5	0	0	0	0	0	132	38	0	29	0	55	0	423
Total	254	440	0	6	0	0	0	0	0	386	173	0	146	0	210	0	1615
16:00	67	143	0	0	0	0	0	0	0	108	78	0	34	0	39	0	469
16:15	97	134	0	4	0	0	0	0	0	119	48	0	41	0	43	0	486
16:30	103	120	0	1	0	0	0	0	0	111	71	0	36	0	67	0	509
16:45	61	103	0	0	0	0	0	0	0	129	60	0	55	0	62	0	470
Total	328	500	0	5	0	0	0	0	0	467	257	0	166	0	211	0	1934
17:00	79	120	0	0	0	0	0	0	0	134	72	0	38	0	60	1	504
17:15	59	99	0	1	0	0	0	0	0	110	44	0	39	0	60	0	412
17:30	63	88	0	1	0	0	0	0	0	100	36	0	45	0	58	0	391
17:45	53	70	0	2	0	0	0	0	0	106	46	0	36	0	61	0	374
Total	254	377	0	4	0	0	0	0	0	450	198	0	158	0	239	1	1681
Grand Total	1279	2095	0	16	0	0	0	0	0	1931	792	0	895	0	1418	2	8428
Apprch %	37.7	61.8	0	0.5	0	0	0	0	0	70.9	29.1	0	38.7	0	61.3	0.1	
Total %	15.2	24.9	0	0.2	0	0	0	0	0	22.9	9.4	0	10.6	0	16.8	0	



Minnesota Dept. of Transportation

Traffic Data Collection -Metro

694-94 N RAMP AT SHINGLE CREEK PKWY
 Ref.Pt; 223.650 NORTH RAMP
 Jamar # T-2638 CAH
 TURN MOVEMENT COUNT

File Name : 694-94 N RAMP AT SHINGLE CREEK PKWY
 Site Code : 223.650
 Start Date : 11/7/2012
 Page No : 2

Start Time	SHINGLE CREEK PKWY Southbound					694 / 94 North Ramp Westbound					SHINGLE CREEK PKWY Northbound					694 / 94 North Ramp Eastbound					Int. Total
	Right	Thru	Left	Peds	App. Total	Right	Thru	Left	Peds	App. Total	Right	Thru	Left	Peds	App. Total	Right	Thru	Left	Peds	App. Total	
Peak Hour Analysis From 06:00 to 08:45 - Peak 1 of 1																					
Peak Hour for Entire Intersection Begins at 07:15																					
07:15	43	77	0	0	120	0	0	0	0	0	0	60	16	0	76	43	0	61	0	104	300
07:30	59	72	0	0	131	0	0	0	0	0	0	64	18	0	82	52	0	80	0	132	345
07:45	33	95	0	0	128	0	0	0	0	0	0	75	17	0	92	40	0	85	1	126	346
08:00	39	72	0	0	111	0	0	0	0	0	0	59	18	0	77	55	0	86	0	141	329
Total Volume	174	316	0	0	490	0	0	0	0	0	0	258	69	0	327	190	0	312	1	503	1320
% App. Total	35.5	64.5	0	0		0	0	0	0		0	78.9	21.1	0		37.8	0	62	0.2		
PHF	.737	.832	.000	.000	.935	.000	.000	.000	.000	.000	.000	.860	.958	.000	.889	.864	.000	.907	.250	.892	.954

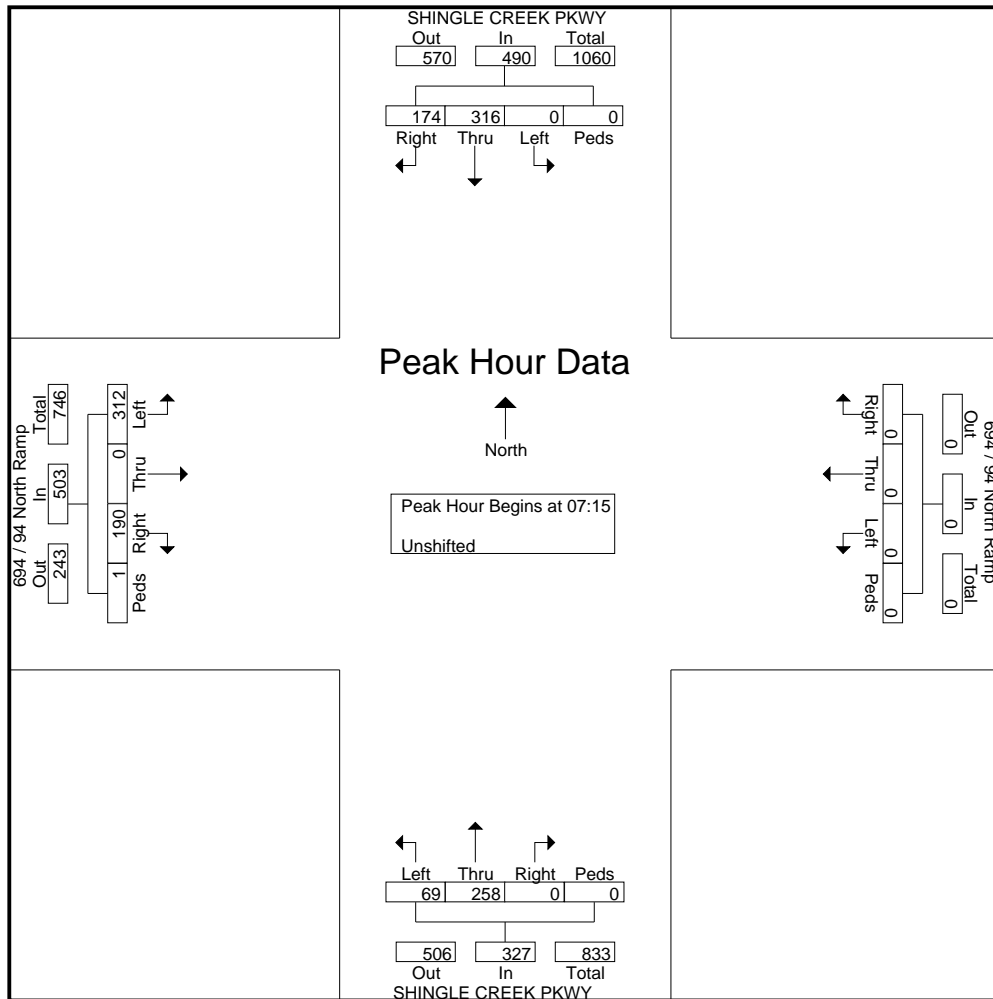



Minnesota Dept. of Transportation

Traffic Data Collection -Metro

694-94 N RAMP AT SHINGLE CREEK PKWY
 Ref.Pt; 223.650 NORTH RAMP
 Jamar # T-2638 CAH
 TURN MOVEMENT COUNT

File Name : 694-94 N RAMP AT SHINGLE CREEK PKWY
 Site Code : 223.650
 Start Date : 11/7/2012
 Page No : 3

Start Time	SHINGLE CREEK PKWY Southbound					694 / 94 North Ramp Westbound					SHINGLE CREEK PKWY Northbound					694 / 94 North Ramp Eastbound					Int. Total
	Rig ht	Thr u	Left	Ped s	App. Total	Rig ht	Thr u	Left	Ped s	App. Total	Right	Thr u	Left	Peds	App. Total	Right	Thr u	Left	Peds	App. Total	
16:15	97	134	0	4	235	0	0	0	0	0	0	119	48	0	167	41	0	43	0	84	486
16:30	103	120	0	1	224	0	0	0	0	0	0	111	71	0	182	36	0	67	0	103	509
16:45	61	103	0	0	164	0	0	0	0	0	0	129	60	0	189	55	0	62	0	117	470
17:00	79	120	0	0	199	0	0	0	0	0	0	134	72	0	206	38	0	60	1	99	504
Total Volume	340	477	0	5	822	0	0	0	0	0	0	493	251	0	744	170	0	232	1	403	1969
% App. Total	41.4	58	0	0.6		0	0	0	0		0	66.3	33.7	0		42.2	0	57.6	0.2		
PHF	.825	.890	.000	.313	.874	.000	.000	.000	.000	.000	.000	.920	.872	.000	.903	.773	.000	.866	.250	.861	.967

Peak Hour Analysis From 15:00 to 17:45 - Peak 1 of 1
 Peak Hour for Entire Intersection Begins at 16:15

