



MINNESOTA DEPT OF TRANSPORTATION

TRAFFIC COLLECTION - METRO

I-94 AT TH-95 / CSAH-15 , W JCT, N RAMP File Name : TH-95 AT I-94 W JCT NORTH RAMPS 2006
 REF.PT: 115.623 Site Code : 00000000
 JAMAR#631 RE Start Date : 7/19/2006
 TURN MOVEMENT COUNT Page No : 1

Groups Printed- Cars & Trucks

Start Time	CSAH-15 / MANNING AVE. Southbound				RAMP FROM I-94 WB Westbound				TH-95 / MANNING AVE. Northbound				RAMP TO I-94 WB Eastbound				Int. Total
	Right	Thru	Left	Peds	Right	Thru	Left	Peds	Right	Thru	Left	Peds	Right	Thru	Left	Peds	
06:00	50	21	0	0	7	0	32	0	0	34	47	0	0	0	0	0	191
06:15	79	33	0	0	24	1	49	0	0	58	66	0	0	0	0	0	310
06:30	65	55	0	0	17	0	43	0	0	72	77	0	0	0	0	0	329
06:45	69	35	0	0	17	0	46	0	0	72	62	0	0	0	0	0	301
Total	263	144	0	0	65	1	170	0	0	236	252	0	0	0	0	0	1131
07:00	92	36	0	0	38	1	39	0	0	68	77	0	0	0	0	0	351
07:15	101	44	0	0	15	0	35	0	0	71	76	0	0	0	0	0	342
07:30	64	58	0	0	31	0	45	0	0	99	68	0	0	0	0	0	365
07:45	67	60	0	0	33	0	24	0	0	90	56	0	0	0	0	0	330
Total	324	198	0	0	117	1	143	0	0	328	277	0	0	0	0	0	1388
08:00	77	55	0	0	21	0	26	0	0	92	50	0	0	0	0	0	321
08:15	60	71	0	0	16	0	32	0	0	84	50	0	0	0	0	0	313
08:30	53	34	0	0	21	0	33	0	0	62	55	0	0	0	0	0	258
08:45	48	55	0	0	14	0	30	0	0	73	59	0	0	0	0	0	279
Total	238	215	0	0	72	0	121	0	0	311	214	0	0	0	0	0	1171
15:00	38	77	0	0	13	0	28	0	0	97	43	0	0	0	0	0	296
15:15	46	72	0	0	14	1	30	0	0	108	40	0	0	0	0	0	311
15:30	60	77	0	0	10	0	45	0	0	117	54	0	0	0	0	0	363
15:45	53	81	0	0	19	1	48	0	0	122	43	0	0	0	0	0	367
Total	197	307	0	0	56	2	151	0	0	444	180	0	0	0	0	0	1337
16:00	41	90	0	0	14	1	37	0	0	121	41	0	0	0	0	0	345
16:15	50	90	0	0	18	0	41	0	0	118	30	0	0	0	0	0	347
16:30	53	104	0	0	24	1	38	0	0	118	29	0	0	0	0	0	367
16:45	48	116	0	0	17	1	44	0	0	128	42	0	0	0	0	0	396
Total	192	400	0	0	73	3	160	0	0	485	142	0	0	0	0	0	1455
17:00	58	99	0	0	20	0	56	0	0	116	43	0	0	0	0	0	392
17:15	55	100	0	0	24	0	34	0	0	131	30	0	0	0	0	0	374
17:30	51	88	0	0	19	0	44	0	0	125	40	0	0	0	0	0	367
17:45	49	80	0	0	17	0	39	0	0	140	37	0	0	0	0	0	362
Total	213	367	0	0	80	0	173	0	0	512	150	0	0	0	0	0	1495
Grand Total	1427	1631	0	0	463	7	918	0	0	2316	1215	0	0	0	0	0	7977
Apprch %	46.7	53.3	0	0	33.4	0.5	66.1	0	0	65.6	34.4	0	0	0	0	0	
Total %	17.9	20.4	0	0	5.8	0.1	11.5	0	0	29	15.2	0	0	0	0	0	



MINNESOTA DEPT OF TRANSPORTATION

TRAFFIC COLLECTION - METRO

I-94 AT TH-95 / CSAH-15 , W JCT, N RAMP File Name : TH-95 AT I-94 W JCT NORTH RAMPS 2006
 REF.PT: 115.623 Site Code : 00000000
 JAMAR#631 RE Start Date : 7/19/2006
 TURN MOVEMENT COUNT Page No : 2

Start Time	CSAH-15 / MANNING AVE. Southbound					RAMP FROM I-94 WB Westbound					TH-95 / MANNING AVE. Northbound					RAMP TO I-94 WB Eastbound					Int. Total
	Right	Thru	Left	Peds	App. Total	Right	Thru	Left	Peds	App. Total	Right	Thru	Left	Peds	App. Total	Right	Thru	Left	Peds	App. Total	
Peak Hour Analysis From 06:00 to 08:45 - Peak 1 of 1																					
Peak Hour for Entire Intersection Begins at 07:00																					
07:00	92	36	0	0	128	38	1	39	0	78	0	68	77	0	145	0	0	0	0	0	351
07:15	101	44	0	0	145	15	0	35	0	50	0	71	76	0	147	0	0	0	0	0	342
07:30	64	58	0	0	122	31	0	45	0	76	0	99	68	0	167	0	0	0	0	0	365
07:45	67	60	0	0	127	33	0	24	0	57	0	90	56	0	146	0	0	0	0	0	330
Total Volume	324	198	0	0	522	117	1	143	0	261	0	328	277	0	605	0	0	0	0	0	1388
% App. Total	62.1	37.9	0	0		44.8	0.4	54.8	0		0	54.2	45.8	0		0	0	0	0	0	
PHF	.802	.825	.000	.000	.900	.770	.250	.794	.000	.837	.000	.828	.899	.000	.906	.000	.000	.000	.000	.000	.951

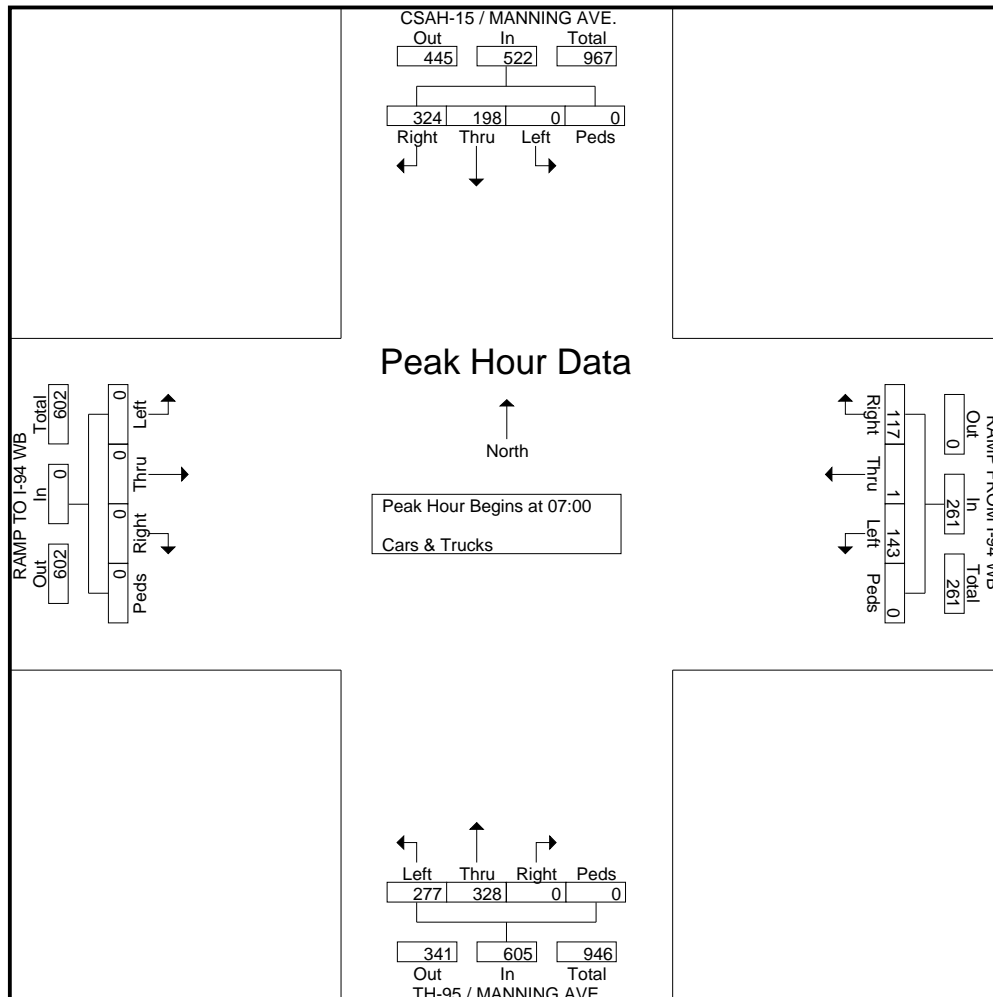



MINNESOTA DEPT OF TRANSPORTATION

TRAFFIC COLLECTION - METRO

I-94 AT TH-95 / CSAH-15 , W JCT, N RAMP File Name : TH-95 AT I-94 W JCT NORTH RAMPS 2006
 REF.PT: 115.623 Site Code : 00000000
 JAMAR#631 RE Start Date : 7/19/2006
 TURN MOVEMENT COUNT Page No : 3

Start Time	CSAH-15 / MANNING AVE. Southbound					RAMP FROM I-94 WB Westbound					TH-95 / MANNING AVE. Northbound					RAMP TO I-94 WB Eastbound					Int. Total
	Right	Thru	Left	Peds	App. Total	Right	Thru	Left	Peds	App. Total	Right	Thru	Left	Peds	App. Total	Right	Thru	Left	Peds	App. Total	
16:30	53	104	0	0	157	24	1	38	0	63	0	118	29	0	147	0	0	0	0	0	367
16:45	48	116	0	0	164	17	1	44	0	62	0	128	42	0	170	0	0	0	0	0	396
17:00	58	99	0	0	157	20	0	56	0	76	0	116	43	0	159	0	0	0	0	0	392
17:15	55	100	0	0	155	24	0	34	0	58	0	131	30	0	161	0	0	0	0	0	374
Total Volume	214	419	0	0	633	85	2	172	0	259	0	493	144	0	637	0	0	0	0	0	1529
% App. Total	33.8	66.2	0	0		32.8	0.8	66.4	0		0	77.4	22.6	0		0	0	0	0	0	
PHF	.922	.903	.000	.000	.965	.885	.500	.768	.000	.852	.000	.941	.837	.000	.937	.000	.000	.000	.000	.000	.965

Peak Hour Analysis From 15:00 to 17:45 - Peak 1 of 1
 Peak Hour for Entire Intersection Begins at 16:30

