



MINNESOTA DEPT OF TRANSPORTATION

TRAFFIC DATA COLLECTION - METRO

TH-100 AT 57TH AVE N, EAST RAMPS
 REF.PT.: 014.894
 JAMAR # D4-3358 KF
 TURN MOVEMENT COUNT

File Name : TH-100 at 57th Ave N east ramp 2007
 Site Code : 00000000
 Start Date : 5/17/2007
 Page No : 1

Groups Printed- Cars & Trucks

Start Time	NB FRT RD & RAMP TO TH-100 NB Southbound				57TH AVE N Westbound				RAMP FROM TH-100 NB Northbound				57TH AVE N Eastbound				Int. Total
	Left	Thru	Right	Peds	Left	Thru	Right	Peds	Left	Thru	Right	Peds	Left	Thru	Right	Peds	
06:00	0	0	0	0	0	64	20	0	2	3	11	0	11	23	0	0	134
06:15	0	0	0	0	0	72	27	1	2	6	15	0	20	31	0	0	174
06:30	0	0	0	0	0	83	38	0	4	11	14	0	25	36	0	0	211
06:45	0	0	0	0	0	69	28	0	4	31	17	0	18	48	0	0	215
Total	0	0	0	0	0	288	113	1	12	51	57	0	74	138	0	0	734
07:00	0	0	0	0	0	83	35	0	10	25	20	0	31	50	0	0	254
07:15	0	0	0	0	0	104	45	0	9	25	21	0	28	50	0	0	282
07:30	0	0	0	0	0	78	48	0	13	28	25	0	43	70	0	0	305
07:45	0	0	0	0	0	94	43	0	27	51	19	0	33	65	0	0	332
Total	0	0	0	0	0	359	171	0	59	129	85	0	135	235	0	0	1173
08:00	0	0	0	0	0	77	54	0	10	40	21	0	27	68	0	0	297
08:15	0	0	0	0	0	96	46	0	7	22	24	0	35	73	0	0	303
08:30	0	0	0	0	0	95	42	0	14	42	18	0	27	47	0	0	285
08:45	0	0	0	0	0	69	29	0	16	41	16	0	26	53	0	0	250
Total	0	0	0	0	0	337	171	0	47	145	79	0	115	241	0	0	1135
*** BREAK ***																	
15:00	0	0	0	0	0	133	66	0	11	28	43	0	55	113	0	0	449
15:15	0	0	0	0	0	97	45	0	17	37	45	0	64	100	0	0	405
15:30	0	0	0	0	0	83	42	0	18	31	42	0	61	136	0	0	413
15:45	0	0	0	0	0	95	47	0	27	48	67	0	52	124	0	0	460
Total	0	0	0	0	0	408	200	0	73	144	197	0	232	473	0	0	1727
16:00	0	0	0	0	0	105	52	0	16	38	44	0	77	135	0	0	467
16:15	0	0	0	0	0	116	48	0	18	65	59	0	51	154	0	0	511
16:30	0	0	0	0	0	105	58	2	21	59	44	0	69	119	0	0	477
16:45	0	0	0	0	0	108	49	0	18	73	55	0	63	159	0	0	525
Total	0	0	0	0	0	434	207	2	73	235	202	0	260	567	0	0	1980
17:00	0	0	0	0	0	96	37	0	20	83	57	0	68	151	0	0	512
17:15	0	0	0	0	0	131	65	0	20	83	46	0	57	155	0	0	557
17:30	0	0	0	0	0	116	46	0	14	76	37	0	56	184	0	0	529
17:45	0	0	0	0	0	113	49	0	30	77	65	0	49	150	0	0	533
Total	0	0	0	0	0	456	197	0	84	319	205	0	230	640	0	0	2131
Grand Total	0	0	0	0	0	2282	1059	3	348	1023	825	0	1046	2294	0	0	8880
Apprch %	0	0	0	0	0	68.2	31.7	0.1	15.8	46.6	37.6	0	31.3	68.7	0	0	
Total %	0	0	0	0	0	25.7	11.9	0	3.9	11.5	9.3	0	11.8	25.8	0	0	



MINNESOTA DEPT OF TRANSPORTATION

TRAFFIC DATA COLLECTION - METRO

TH-100 AT 57TH AVE N, EAST RAMPS
 REF.PT.: 014.894
 JAMAR # D4-3358 KF
 TURN MOVEMENT COUNT

File Name : TH-100 at 57th Ave N east ramp 2007
 Site Code : 00000000
 Start Date : 5/17/2007
 Page No : 2

Start Time	NB FRT RD & RAMP TO TH-100 NB Southbound					57TH AVE N Westbound					RAMP FROM TH-100 NB Northbound					57TH AVE N Eastbound					Int. Total
	Left	Thru	Right	Peds	App. Total	Left	Thru	Right	Peds	App. Total	Left	Thru	Right	Peds	App. Total	Left	Thru	Right	Peds	App. Total	
Peak Hour Analysis From 06:00 to 08:45 - Peak 1 of 1																					
Peak Hour for Entire Intersection Begins at 07:30																					
07:30	0	0	0	0	0	0	78	48	0	126	13	28	25	0	66	43	70	0	0	113	305
07:45	0	0	0	0	0	0	94	43	0	137	27	51	19	0	97	33	65	0	0	98	332
08:00	0	0	0	0	0	0	77	54	0	131	10	40	21	0	71	27	68	0	0	95	297
08:15	0	0	0	0	0	0	96	46	0	142	7	22	24	0	53	35	73	0	0	108	303
Total Volume	0	0	0	0	0	0	345	191	0	536	57	141	89	0	287	138	276	0	0	414	1237
% App. Total																					
PHF	.000	.000	.000	.000	.000	.000	.898	.884	.000	.944	.528	.691	.890	.000	.740	.802	.945	.000	.000	.916	.931

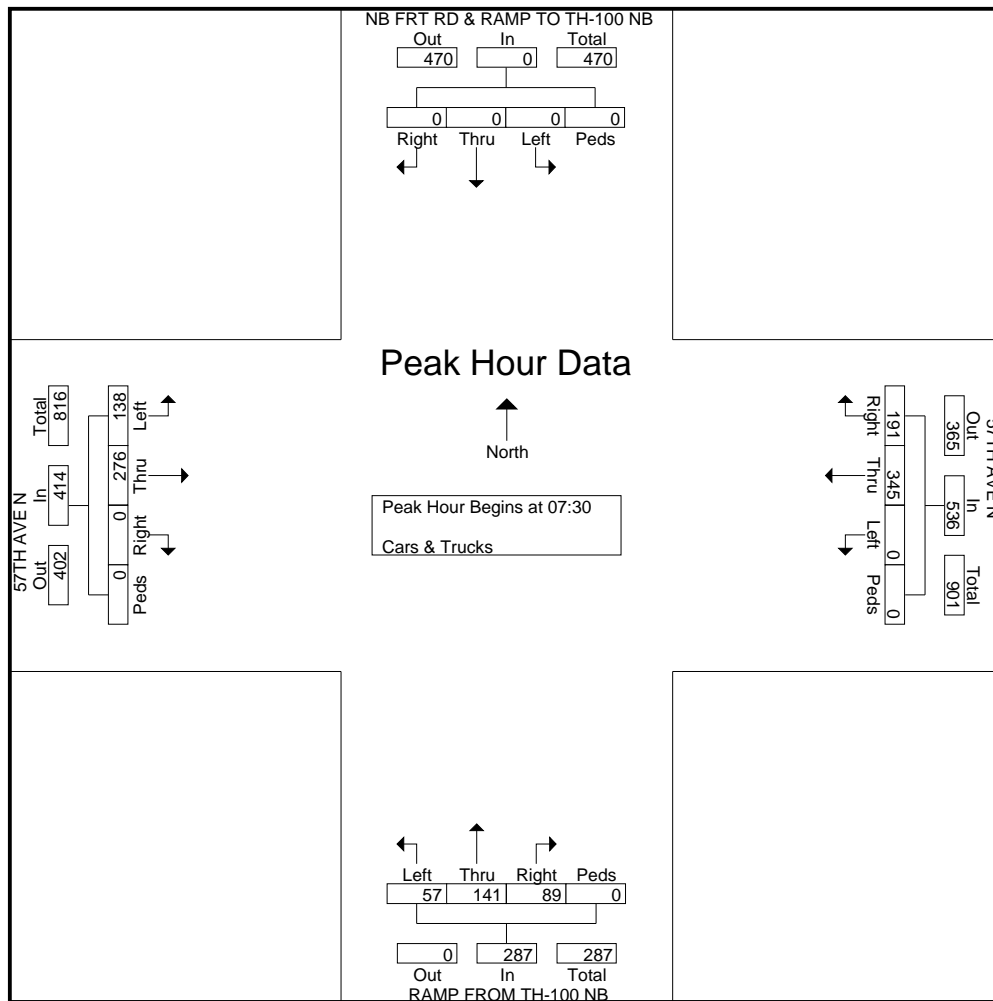



MINNESOTA DEPT OF TRANSPORTATION

TRAFFIC DATA COLLECTION - METRO

TH-100 AT 57TH AVE N, EAST RAMPS
 REF.PT.: 014.894
 JAMAR # D4-3358 KF
 TURN MOVEMENT COUNT

File Name : TH-100 at 57th Ave N east ramp 2007
 Site Code : 00000000
 Start Date : 5/17/2007
 Page No : 3

Start Time	NB FRT RD & RAMP TO TH-100 NB Southbound					57TH AVE N Westbound					RAMP FROM TH-100 NB Northbound					57TH AVE N Eastbound					Int. Total
	Left	Thru	Right	Peds	App. Total	Left	Thru	Right	Peds	App. Total	Left	Thru	Right	Peds	App. Total	Left	Thru	Right	Peds	App. Total	
Peak Hour Analysis From 15:00 to 17:45 - Peak 1 of 1																					
Peak Hour for Entire Intersection Begins at 17:00																					
17:00	0	0	0	0	0	0	96	37	0	133	20	83	57	0	160	68	151	0	0	219	512
17:15	0	0	0	0	0	0	131	65	0	196	20	83	46	0	149	57	155	0	0	212	557
17:30	0	0	0	0	0	0	116	46	0	162	14	76	37	0	127	56	184	0	0	240	529
17:45	0	0	0	0	0	0	113	49	0	162	30	77	65	0	172	49	150	0	0	199	533
Total Volume	0	0	0	0	0	0	456	197	0	653	84	319	205	0	608	230	640	0	0	870	2131
% App. Total																					
PHF	.000	.000	.000	.000	.000	.000	.870	.758	.000	.833	.700	.961	.788	.000	.884	.846	.870	.000	.000	.906	.956

