



MINNESOTA DEPT OF TRANSPORTATION

TRAFFIC DATA COLLECTION - METRO

TH-101 at Pleasant View Rd
 Ref.Pt.: 015.307
 JAMAR # T-2638 CAH
 TURN MOVEMENT COUNT

File Name : TH-101 at Pleasant View Rd 2010
 Site Code : 00000000
 Start Date : 1/14/2010
 Page No : 1

Groups Printed- Cars & Trucks

| Start Time | TH-101 / W 192nd Ave Southbound | | | | PLEASANT VIEW RD Westbound | | | | TH-101 / W 192nd Ave Northbound | | | | PLEASANT VIEW RD Eastbound | | | | Int. Total |
|---------------|---------------------------------|------|-------|------|----------------------------|------|-------|------|---------------------------------|------|-------|------|----------------------------|------|-------|------|------------|
| | Left | Thru | Right | Peds | Left | Thru | Right | Peds | Left | Thru | Right | Peds | Left | Thru | Right | Peds | |
| 06:00 | 0 | 15 | 1 | 0 | 1 | 0 | 0 | 0 | 0 | 23 | 0 | 0 | 7 | 1 | 1 | 0 | 49 |
| 06:15 | 0 | 19 | 1 | 0 | 0 | 1 | 0 | 0 | 0 | 27 | 0 | 0 | 4 | 1 | 3 | 0 | 56 |
| 06:30 | 0 | 32 | 2 | 2 | 2 | 0 | 0 | 0 | 0 | 54 | 1 | 0 | 20 | 0 | 2 | 0 | 115 |
| 06:45 | 0 | 41 | 1 | 0 | 3 | 0 | 0 | 0 | 0 | 57 | 1 | 0 | 25 | 2 | 7 | 0 | 137 |
| Total | 0 | 107 | 5 | 2 | 6 | 1 | 0 | 0 | 0 | 161 | 2 | 0 | 56 | 4 | 13 | 0 | 357 |
| 07:00 | 0 | 40 | 3 | 0 | 3 | 0 | 2 | 0 | 3 | 88 | 1 | 0 | 28 | 2 | 8 | 0 | 178 |
| 07:15 | 0 | 56 | 6 | 0 | 0 | 0 | 2 | 0 | 3 | 106 | 2 | 0 | 43 | 0 | 7 | 0 | 225 |
| 07:30 | 0 | 67 | 3 | 0 | 0 | 1 | 1 | 0 | 1 | 152 | 2 | 0 | 36 | 4 | 9 | 0 | 276 |
| 07:45 | 0 | 80 | 5 | 0 | 1 | 2 | 3 | 0 | 5 | 134 | 1 | 0 | 31 | 3 | 10 | 0 | 275 |
| Total | 0 | 243 | 17 | 0 | 4 | 3 | 8 | 0 | 12 | 480 | 6 | 0 | 138 | 9 | 34 | 0 | 954 |
| 08:00 | 2 | 61 | 7 | 0 | 0 | 0 | 0 | 0 | 4 | 105 | 3 | 0 | 30 | 1 | 11 | 0 | 224 |
| 08:15 | 1 | 68 | 6 | 0 | 2 | 0 | 0 | 0 | 2 | 110 | 0 | 0 | 25 | 2 | 8 | 0 | 224 |
| 08:30 | 0 | 68 | 11 | 0 | 2 | 2 | 0 | 0 | 3 | 79 | 0 | 0 | 27 | 0 | 9 | 0 | 201 |
| 08:45 | 1 | 60 | 6 | 0 | 1 | 2 | 0 | 0 | 4 | 60 | 3 | 0 | 24 | 2 | 9 | 0 | 172 |
| Total | 4 | 257 | 30 | 0 | 5 | 4 | 0 | 0 | 13 | 354 | 6 | 0 | 106 | 5 | 37 | 0 | 821 |
| *** BREAK *** | | | | | | | | | | | | | | | | | |
| 15:00 | 0 | 104 | 16 | 0 | 3 | 2 | 1 | 0 | 2 | 74 | 1 | 0 | 9 | 0 | 5 | 0 | 217 |
| 15:15 | 0 | 90 | 20 | 0 | 0 | 2 | 0 | 0 | 11 | 72 | 8 | 0 | 17 | 2 | 3 | 0 | 225 |
| 15:30 | 2 | 94 | 17 | 0 | 4 | 3 | 0 | 1 | 8 | 66 | 2 | 0 | 15 | 1 | 2 | 0 | 215 |
| 15:45 | 0 | 92 | 13 | 0 | 2 | 1 | 2 | 1 | 4 | 94 | 1 | 0 | 6 | 1 | 6 | 0 | 223 |
| Total | 2 | 380 | 66 | 0 | 9 | 8 | 3 | 2 | 25 | 306 | 12 | 0 | 47 | 4 | 16 | 0 | 880 |
| 16:00 | 0 | 94 | 22 | 0 | 1 | 0 | 0 | 0 | 8 | 85 | 3 | 0 | 4 | 1 | 3 | 0 | 221 |
| 16:15 | 1 | 91 | 25 | 0 | 3 | 0 | 1 | 0 | 7 | 87 | 2 | 0 | 14 | 1 | 10 | 0 | 242 |
| 16:30 | 0 | 106 | 30 | 0 | 1 | 1 | 0 | 0 | 10 | 79 | 2 | 0 | 9 | 0 | 6 | 0 | 244 |
| 16:45 | 1 | 108 | 21 | 0 | 6 | 2 | 2 | 0 | 3 | 75 | 6 | 0 | 22 | 0 | 4 | 0 | 250 |
| Total | 2 | 399 | 98 | 0 | 11 | 3 | 3 | 0 | 28 | 326 | 13 | 0 | 49 | 2 | 23 | 0 | 957 |
| 17:00 | 0 | 141 | 34 | 0 | 3 | 0 | 1 | 0 | 11 | 84 | 3 | 0 | 13 | 4 | 8 | 0 | 302 |
| 17:15 | 4 | 173 | 47 | 0 | 3 | 1 | 0 | 0 | 13 | 99 | 6 | 0 | 9 | 0 | 3 | 0 | 358 |
| 17:30 | 1 | 106 | 52 | 0 | 2 | 2 | 0 | 0 | 14 | 80 | 1 | 0 | 14 | 5 | 5 | 0 | 282 |
| 17:45 | 1 | 128 | 28 | 0 | 2 | 2 | 0 | 0 | 17 | 78 | 4 | 0 | 8 | 3 | 11 | 0 | 282 |
| Total | 6 | 548 | 161 | 0 | 10 | 5 | 1 | 0 | 55 | 341 | 14 | 0 | 44 | 12 | 27 | 0 | 1224 |
| Grand Total | 14 | 1934 | 377 | 2 | 45 | 24 | 15 | 2 | 133 | 1968 | 53 | 0 | 440 | 36 | 150 | 0 | 5193 |
| Apprch % | 0.6 | 83.1 | 16.2 | 0.1 | 52.3 | 27.9 | 17.4 | 2.3 | 6.2 | 91.4 | 2.5 | 0 | 70.3 | 5.8 | 24 | 0 | |
| Total % | 0.3 | 37.2 | 7.3 | 0 | 0.9 | 0.5 | 0.3 | 0 | 2.6 | 37.9 | 1 | 0 | 8.5 | 0.7 | 2.9 | 0 | |

Left turning traffic, EB TH-101, had no problems and no backups. At TH-101 the PM was the tight one at 5 PM - EB Pleasant View Rd had about 6 cars in line which made it difficult for SB TH-101 cars to make the right turn onto Pleasant View Rd., therefore stacking cars in the right turn lane. NB cars drive like they don't know how: cars turning left on to Pleasant View Rd had to wait for a break, but other cars would try to get around them even if there was a car turning right on to Pleasant View Rd. At this location there is No right turn lane northbound.
 CAH



MINNESOTA DEPT OF TRANSPORTATION

TRAFFIC DATA COLLECTION - METRO

TH-101 at Pleasant View Rd
 Ref.Pt.: 015.307
 JAMAR # T-2638 CAH
 TURN MOVEMENT COUNT

File Name : TH-101 at Pleasant View Rd 2010
 Site Code : 00000000
 Start Date : 1/14/2010
 Page No : 2

| Start Time | TH-101 / W 192nd Ave Southbound | | | | | PLEASANT VIEW RD Westbound | | | | | TH-101 / W 192nd Ave Northbound | | | | | PLEASANT VIEW RD Eastbound | | | | | Int. Total |
|--|---------------------------------|------|-------|------|------------|----------------------------|------|-------|------|------------|---------------------------------|------|-------|------|------------|----------------------------|------|-------|------|------------|------------|
| | Left | Thru | Right | Peds | App. Total | Left | Thru | Right | Peds | App. Total | Left | Thru | Right | Peds | App. Total | Left | Thru | Right | Peds | App. Total | |
| Peak Hour Analysis From 06:00 to 08:45 - Peak 1 of 1 | | | | | | | | | | | | | | | | | | | | | |
| Peak Hour for Entire Intersection Begins at 07:15 | | | | | | | | | | | | | | | | | | | | | |
| 07:15 | 0 | 56 | 6 | 0 | 62 | 0 | 0 | 2 | 0 | 2 | 3 | 106 | 2 | 0 | 111 | 43 | 0 | 7 | 0 | 50 | 225 |
| 07:30 | 0 | 67 | 3 | 0 | 70 | 0 | 1 | 1 | 0 | 2 | 1 | 152 | 2 | 0 | 155 | 36 | 4 | 9 | 0 | 49 | 276 |
| 07:45 | 0 | 80 | 5 | 0 | 85 | 1 | 2 | 3 | 0 | 6 | 5 | 134 | 1 | 0 | 140 | 31 | 3 | 10 | 0 | 44 | 275 |
| 08:00 | 2 | 61 | 7 | 0 | 70 | 0 | 0 | 0 | 0 | 0 | 4 | 105 | 3 | 0 | 112 | 30 | 1 | 11 | 0 | 42 | 224 |
| Total Volume | 2 | 264 | 21 | 0 | 287 | 1 | 3 | 6 | 0 | 10 | 13 | 497 | 8 | 0 | 518 | 140 | 8 | 37 | 0 | 185 | 1000 |
| % App. Total | 0.7 | 92 | 7.3 | 0 | | 10 | 30 | 60 | 0 | | 2.5 | 95.9 | 1.5 | 0 | | 75.7 | 4.3 | 20 | 0 | | |
| PHF | .250 | .825 | .750 | .000 | .844 | .250 | .375 | .500 | .000 | .417 | .650 | .817 | .667 | .000 | .835 | .814 | .500 | .841 | .000 | .925 | .906 |

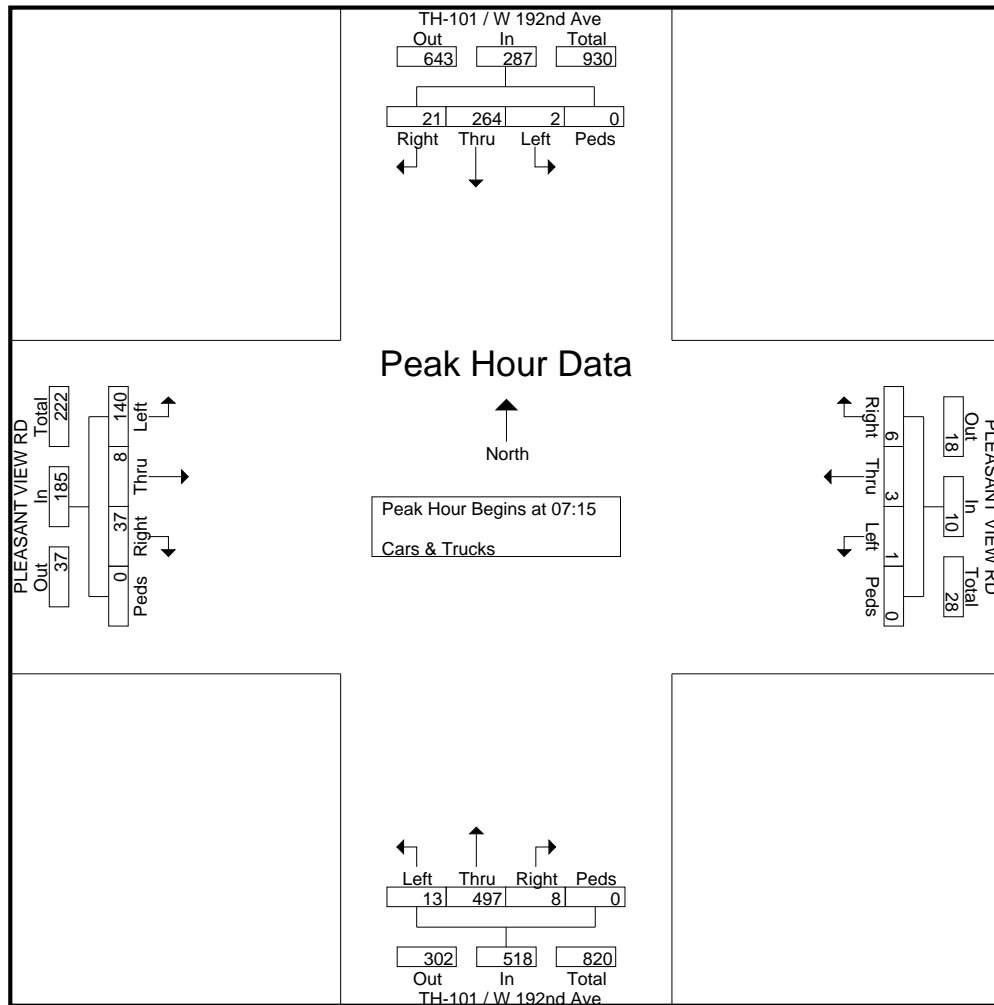



MINNESOTA DEPT OF TRANSPORTATION

TRAFFIC DATA COLLECTION - METRO

TH-101 at Pleasant View Rd
 Ref.Pt.: 015.307
 JAMAR # T-2638 CAH
 TURN MOVEMENT COUNT

File Name : TH-101 at Pleasant View Rd 2010
 Site Code : 00000000
 Start Date : 1/14/2010
 Page No : 3

| Start Time | TH-101 / W 192nd Ave Southbound | | | | | PLEASANT VIEW RD Westbound | | | | | TH-101 / W 192nd Ave Northbound | | | | | PLEASANT VIEW RD Eastbound | | | | | Int. Total |
|------------|---------------------------------|------|-------|------|------------|----------------------------|------|-------|------|------------|---------------------------------|------|-------|------|------------|----------------------------|------|-------|------|------------|------------|
| | Left | Thru | Right | Peds | App. Total | Left | Thru | Right | Peds | App. Total | Left | Thru | Right | Peds | App. Total | Left | Thru | Right | Peds | App. Total | |

Peak Hour Analysis From 15:00 to 17:45 - Peak 1 of 1
 Peak Hour for Entire Intersection Begins at 17:00

| | | | | | | | | | | | | | | | | | | | | | |
|--------------|------|------|------|------|------|------|------|------|------|-------|------|------|------|------|------|------|------|------|------|------|------|
| 17:00 | 0 | 141 | 34 | 0 | 175 | 3 | 0 | 1 | 0 | 4 | 11 | 84 | 3 | 0 | 98 | 13 | 4 | 8 | 0 | 25 | 302 |
| 17:15 | 4 | 173 | 47 | 0 | 224 | 3 | 1 | 0 | 0 | 4 | 13 | 99 | 6 | 0 | 118 | 9 | 0 | 3 | 0 | 12 | 358 |
| 17:30 | 1 | 106 | 52 | 0 | 159 | 2 | 2 | 0 | 0 | 4 | 14 | 80 | 1 | 0 | 95 | 14 | 5 | 5 | 0 | 24 | 282 |
| 17:45 | 1 | 128 | 28 | 0 | 157 | 2 | 2 | 0 | 0 | 4 | 17 | 78 | 4 | 0 | 99 | 8 | 3 | 11 | 0 | 22 | 282 |
| Total Volume | 6 | 548 | 161 | 0 | 715 | 10 | 5 | 1 | 0 | 16 | 55 | 341 | 14 | 0 | 410 | 44 | 12 | 27 | 0 | 83 | 1224 |
| % App. Total | 0.8 | 76.6 | 22.5 | 0 | | 62.5 | 31.2 | 6.2 | 0 | | 13.4 | 83.2 | 3.4 | 0 | | 53 | 14.5 | 32.5 | 0 | | |
| PHF | .375 | .792 | .774 | .000 | .798 | .833 | .625 | .250 | .000 | 1.000 | .809 | .861 | .583 | .000 | .869 | .786 | .600 | .614 | .000 | .830 | .855 |

