

Alliant Engineering Inc Minneapolis, MN 55415

TH-55 at TH-13
Ref.Pt.: 199.935
Alliant Engineering Inc
TURN MOVEMENT COUNT

File Name : 01_TH 55 at TH 13_021610
Site Code : 00000001
Start Date : 2/16/2010
Page No : 1

Groups Printed- Unshifted - Bank 1

Start Time	TH-55 Southbound				TH-13 Westbound				TH-55 Northbound				TH-13 Eastbound				Int. Total
	Left	Thru	Right	Peds	Left	Thru	Right	Peds	Left	Thru	Right	Peds	Left	Thru	Right	Peds	
06:00	0	94	16	0	2	1	0	0	5	123	2	0	42	3	2	0	290
06:15	0	127	21	0	2	2	0	0	2	202	0	0	65	3	3	0	427
06:30	0	195	34	0	4	3	0	0	3	229	3	0	86	9	2	0	568
06:45	1	267	39	0	5	3	1	0	7	249	5	0	88	6	6	0	677
Total	1	683	110	0	13	9	1	0	17	803	10	0	281	21	13	0	1962
07:00	0	204	52	0	5	2	4	0	0	365	0	0	120	27	4	0	783
07:15	1	230	50	0	5	11	1	0	2	394	4	0	158	35	8	0	899
07:30	2	305	82	0	2	17	0	0	4	376	4	0	167	30	7	0	996
07:45	0	355	86	0	3	7	1	0	8	336	8	0	144	41	14	1	1004
Total	3	1094	270	0	15	37	6	0	14	1471	16	0	589	133	33	1	3682
08:00	0	266	68	0	2	10	2	0	6	276	4	0	99	43	7	0	783
08:15	1	245	67	0	9	10	0	0	2	216	5	0	88	25	13	0	681
08:30	1	223	58	0	4	6	3	0	3	198	4	0	89	11	6	0	606
08:45	2	166	45	0	4	9	2	0	6	174	6	0	57	19	9	0	499
Total	4	900	238	0	19	35	7	0	17	864	19	0	333	98	35	0	2569
09:00	2	144	33	0	4	5	2	0	3	138	4	0	41	11	5	0	392
09:15	2	142	34	0	2	4	1	0	4	145	2	0	35	11	3	0	385
*** BREAK ***																	
Total	4	286	67	0	6	9	3	0	7	283	6	0	76	22	8	0	777
*** BREAK ***																	
10:30	2	119	31	0	4	5	0	0	6	109	6	0	32	6	0	0	320
10:45	3	86	26	0	3	10	0	0	3	90	8	0	35	7	9	0	280
Total	5	205	57	0	7	15	0	0	9	199	14	0	67	13	9	0	600
11:00	1	96	29	0	4	15	1	0	6	113	3	0	21	8	4	0	301
11:15	3	106	27	0	2	7	0	0	5	135	12	0	32	12	2	0	343
11:30	1	106	33	0	5	6	0	0	8	121	7	0	30	9	6	0	332
11:45	1	126	26	0	2	7	1	0	2	113	8	0	23	12	8	0	329
Total	6	434	115	0	13	35	2	0	21	482	30	0	106	41	20	0	1305
12:00	0	119	31	0	4	7	0	0	5	114	7	0	41	16	9	0	353
12:15	2	108	30	0	0	10	1	0	5	122	9	0	25	12	6	0	330
12:30	1	109	41	0	3	11	0	0	4	126	8	0	30	14	5	0	352
12:45	0	107	44	0	10	20	2	0	5	99	4	0	42	9	9	0	351
Total	3	443	146	0	17	48	3	0	19	461	28	0	138	51	29	0	1386
13:00	1	118	35	0	7	11	2	0	6	119	7	0	38	9	4	0	357
13:15	1	122	34	0	4	4	1	0	4	112	5	0	19	13	5	0	324
*** BREAK ***																	
Total	2	240	69	0	11	15	3	0	10	231	12	0	57	22	9	0	681
*** BREAK ***																	
14:30	3	164	32	0	3	16	1	0	7	129	14	0	46	17	10	0	442
14:45	4	168	39	0	7	8	1	0	8	151	6	0	30	8	5	0	435
Total	7	332	71	0	10	24	2	0	15	280	20	0	76	25	15	0	877
15:00	1	185	49	0	6	8	1	0	2	174	8	0	38	10	9	0	491
15:15	3	222	47	0	5	10	3	0	2	169	5	0	33	10	8	0	517
15:30	3	236	82	0	8	15	1	0	2	314	10	0	76	17	6	0	770
15:45	0	207	72	0	4	9	0	0	8	241	4	0	54	20	5	0	624
Total	7	850	250	0	23	42	5	0	14	898	27	0	201	57	28	0	2402

Alliant Engineering Inc Minneapolis, MN 55415

TH-55 at TH-13
 Ref.Pt.: 199.935
 Alliant Engineering Inc
 TURN MOVEMENT COUNT

File Name : 01_TH 55 at TH 13_021610
 Site Code : 00000001
 Start Date : 2/16/2010
 Page No : 2

Groups Printed- Unshifted - Bank 1

Start Time	TH-55 Southbound				TH-13 Westbound				TH-55 Northbound				TH-13 Eastbound				Int. Total
	Left	Thru	Right	Peds	Left	Thru	Right	Peds	Left	Thru	Right	Peds	Left	Thru	Right	Peds	
16:00	0	234	97	0	4	14	1	0	8	247	7	0	70	16	3	0	701
16:15	1	268	100	0	1	8	0	0	13	228	13	0	54	18	4	0	708
16:30	2	266	102	0	7	18	6	1	13	269	13	0	88	30	7	0	822
16:45	2	284	136	0	6	24	0	0	7	291	11	0	82	19	10	0	872
Total	5	1052	435	0	18	64	7	1	41	1035	44	0	294	83	24	0	3103
17:00	3	268	120	0	6	25	1	0	5	343	9	0	91	27	3	0	901
17:15	2	243	103	0	7	24	0	0	9	290	11	0	72	21	3	0	785
17:30	1	249	120	0	2	18	1	0	7	247	7	0	53	25	7	0	737
17:45	1	237	89	0	2	16	0	0	4	207	9	0	43	13	7	0	628
Total	7	997	432	0	17	83	2	0	25	1087	36	0	259	86	20	0	3051
Grand Total	54	7516	2260	0	169	416	41	1	209	8094	262	0	2477	652	243	1	22395
Apprch %	0.5	76.5	23	0	27	66.3	6.5	0.2	2.4	94.5	3.1	0	73.4	19.3	7.2	0	
Total %	0.2	33.6	10.1	0	0.8	1.9	0.2	0	0.9	36.1	1.2	0	11.1	2.9	1.1	0	
Unshifted	52	7258	2181	0	161	400	41	1	194	7856	252	0	2420	641	227	1	21685
% Unshifted	96.3	96.6	96.5	0	95.3	96.2	100	100	92.8	97.1	96.2	0	97.7	98.3	93.4	100	96.8
Bank 1	2	258	79	0	8	16	0	0	15	238	10	0	57	11	16	0	710
% Bank 1	3.7	3.4	3.5	0	4.7	3.8	0	0	7.2	2.9	3.8	0	2.3	1.7	6.6	0	3.2

Alliant Engineering Inc Minneapolis, MN 55415

TH-55 at TH-13
 Ref.Pt.: 199.935
 Alliant Engineering Inc
 TURN MOVEMENT COUNT

File Name : 01_TH 55 at TH 13_021610
 Site Code : 00000001
 Start Date : 2/16/2010
 Page No : 3

Start Time	TH-55 Southbound					TH-13 Westbound					TH-55 Northbound					TH-13 Eastbound					Int. Total
	Left	Thru	Right	Peds	App. Total	Left	Thru	Right	Peds	App. Total	Left	Thru	Right	Peds	App. Total	Left	Thru	Right	Peds	App. Total	
Peak Hour Analysis From 06:00 to 09:15 - Peak 1 of 1																					
Peak Hour for Entire Intersection Begins at 07:00																					
07:00	0	204	52	0	256	5	2	4	0	11	0	365	0	0	365	120	27	4	0	151	783
07:15	1	230	50	0	281	5	11	1	0	17	2	394	4	0	400	158	35	8	0	201	899
07:30	2	305	82	0	389	2	17	0	0	19	4	376	4	0	384	167	30	7	0	204	996
07:45	0	355	86	0	441	3	7	1	0	11	8	336	8	0	352	144	41	14	1	200	1004
Total Volume	3	1094	270	0	1367	15	37	6	0	58	14	1471	16	0	1501	589	133	33	1	756	3682
% App. Total	0.2	80	19.8	0		25.9	63.8	10.3	0		0.9	98	1.1	0		77.9	17.6	4.4	0.1		
PHF	.375	.770	.785	.000	.775	.750	.544	.375	.000	.763	.438	.933	.500	.000	.938	.882	.811	.589	.250	.926	.917

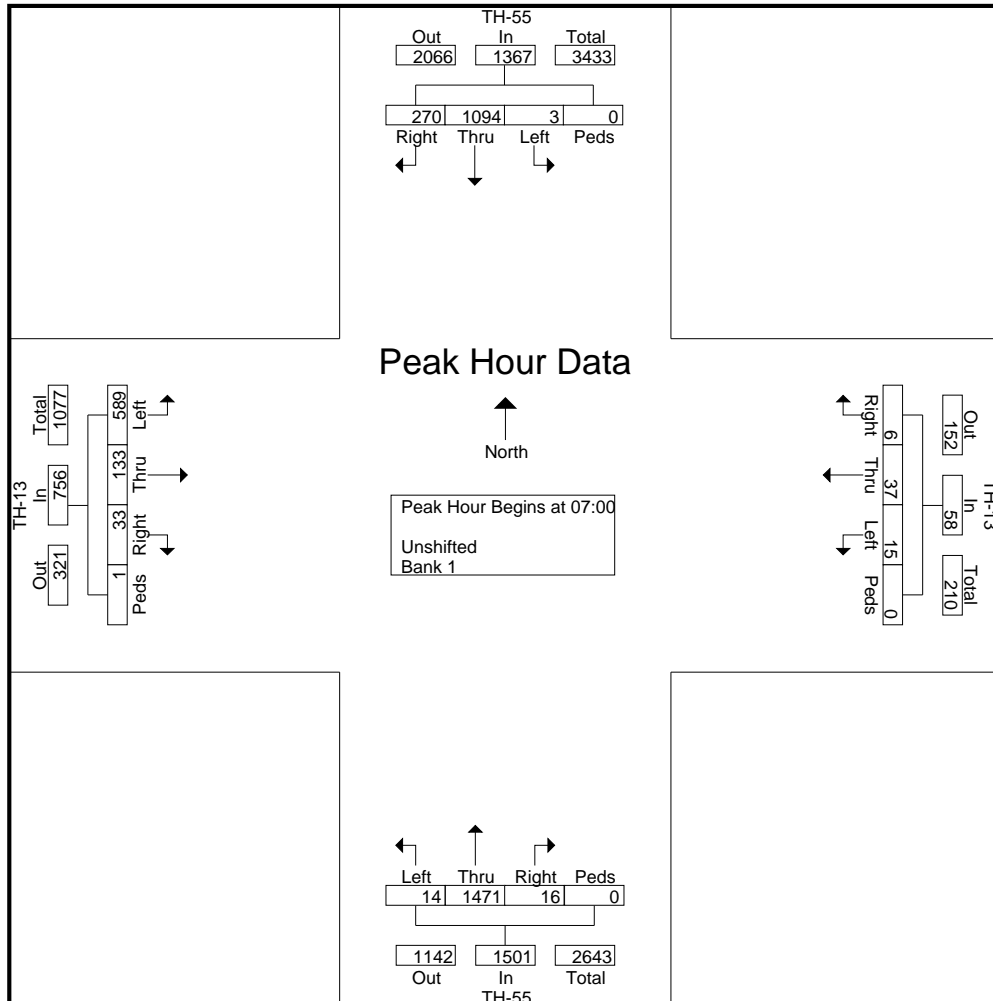

Alliant Engineering Inc Minneapolis, MN 55415

TH-55 at TH-13
 Ref.Pt.: 199.935
 Alliant Engineering Inc
 TURN MOVEMENT COUNT

File Name : 01_TH 55 at TH 13_021610
 Site Code : 00000001
 Start Date : 2/16/2010
 Page No : 4

Start Time	TH-55 Southbound					TH-13 Westbound					TH-55 Northbound					TH-13 Eastbound					Int. Total
	Left	Thru	Right	Peds	App. Total	Left	Thru	Right	Peds	App. Total	Left	Thru	Right	Peds	App. Total	Left	Thru	Right	Peds	App. Total	
Peak Hour Analysis From 15:00 to 17:45 - Peak 1 of 1																					
Peak Hour for Entire Intersection Begins at 16:30																					
16:30	2	266	102	0	370	7	18	6	1	32	13	269	13	0	295	88	30	7	0	125	822
16:45	2	284	136	0	422	6	24	0	0	30	7	291	11	0	309	82	19	10	0	111	872
17:00	3	268	120	0	391	6	25	1	0	32	5	343	9	0	357	91	27	3	0	121	901
17:15	2	243	103	0	348	7	24	0	0	31	9	290	11	0	310	72	21	3	0	96	785
Total Volume	9	1061	461	0	1531	26	91	7	1	125	34	1193	44	0	1271	333	97	23	0	453	3380
% App. Total	0.6	69.3	30.1	0		20.8	72.8	5.6	0.8		2.7	93.9	3.5	0		73.5	21.4	5.1	0		
PHF	.750	.934	.847	.000	.907	.929	.910	.292	.250	.977	.654	.870	.846	.000	.890	.915	.808	.575	.000	.906	.938

