

# Alliant Engineering Inc Minneapolis, MN 55415

TH-149 at Lone Oak Parkway  
Ref.Pt.: 003.613  
Alliant Engineering Inc  
TURN MOVEMENT COUNT

File Name : 16\_TH 149 at Lone Oak Pkwy\_022310  
Site Code : 00000016  
Start Date : 2/23/2010  
Page No : 1

### Groups Printed- Unshifted - Bank 1

Start Time	TH-149 / Dodd Rd Southbound				Lone Oak Parkway Westbound				TH-149 / Dodd Rd Northbound				commercial entrance Eastbound				Int. Total
	Left	Thru	Right	Peds	Left	Thru	Right	Peds	Left	Thru	Right	Peds	Left	Thru	Right	Peds	
06:00	21	70	5	1	1	1	1	0	5	60	7	0	0	1	0	0	173
06:15	29	76	16	0	0	0	0	0	1	69	17	0	1	0	1	0	210
06:30	41	89	17	0	1	1	1	0	5	96	11	0	3	1	3	0	269
06:45	38	104	24	2	1	1	3	0	11	96	15	0	3	0	2	0	300
Total	129	339	62	3	3	3	5	0	22	321	50	0	7	2	6	0	952
07:00	48	97	23	0	1	0	6	0	4	143	13	0	3	0	3	0	341
07:15	64	124	28	0	5	0	9	1	8	158	21	0	5	2	3	0	428
07:30	46	112	22	1	1	1	6	1	13	164	22	0	6	2	3	0	400
07:45	63	157	16	0	1	0	6	0	9	133	32	0	2	5	3	0	427
Total	221	490	89	1	8	1	27	2	34	598	88	0	16	9	12	0	1596
08:00	85	139	29	0	2	2	5	0	5	122	16	0	5	5	7	0	422
08:15	51	133	27	1	2	0	5	0	10	96	14	1	3	0	6	0	349
08:30	28	88	22	0	3	1	5	0	5	88	8	0	5	2	4	0	259
08:45	43	86	13	0	2	1	6	0	7	91	8	0	5	0	2	0	264
Total	207	446	91	1	9	4	21	0	27	397	46	1	18	7	19	0	1294
09:00	39	89	18	0	1	3	10	0	5	90	12	0	0	0	2	0	269
09:15	20	64	13	0	1	2	4	0	4	77	4	0	2	3	6	0	200
*** BREAK ***																	
Total	59	153	31	0	2	5	14	0	9	167	16	0	2	3	8	0	469
*** BREAK ***																	
10:30	18	77	7	0	5	1	13	0	4	75	5	0	7	2	7	0	221
10:45	23	50	11	0	5	1	10	0	2	84	1	0	3	0	4	0	194
Total	41	127	18	0	10	2	23	0	6	159	6	0	10	2	11	0	415
11:00	5	46	7	0	1	2	15	0	5	78	0	0	8	1	13	0	181
11:15	9	61	12	0	2	7	17	0	10	73	2	0	7	5	12	0	217
11:30	11	61	17	0	7	3	16	0	7	94	1	0	8	3	16	0	244
11:45	12	64	5	0	7	8	9	0	10	90	3	0	9	5	24	0	246
Total	37	232	41	0	17	20	57	0	32	335	6	0	32	14	65	0	888
12:00	12	66	7	0	8	7	12	0	25	86	4	0	8	2	11	0	248
12:15	14	61	13	0	6	6	13	0	21	76	5	0	4	5	11	0	235
12:30	7	68	13	0	3	2	11	1	9	86	7	0	15	6	20	0	248
12:45	20	70	4	0	1	1	11	1	7	60	5	0	6	5	12	0	203
Total	53	265	37	0	18	16	47	2	62	308	21	0	33	18	54	0	934
13:00	11	60	8	0	2	1	8	0	8	82	4	0	8	5	6	0	203
13:15	12	63	9	0	4	2	11	0	7	81	6	0	4	6	14	0	219
*** BREAK ***																	
Total	23	123	17	0	6	3	19	0	15	163	10	0	12	11	20	0	422
*** BREAK ***																	
14:15	2	0	0	0	0	0	0	0	0	0	0	0	0	0	0	0	2
14:30	15	75	3	0	8	0	30	0	7	141	2	0	8	2	6	0	297
14:45	16	73	9	0	4	0	22	0	1	105	3	0	4	0	8	0	245
Total	33	148	12	0	12	0	52	0	8	246	5	0	12	2	14	0	544
15:00	16	69	6	0	9	0	24	0	5	119	3	0	8	2	8	0	269
15:15	9	92	3	0	7	1	46	0	3	113	2	0	19	2	2	0	299
15:30	7	76	10	0	11	2	71	0	6	170	4	0	16	3	7	0	383
15:45	10	99	4	0	15	0	43	0	2	134	3	0	10	3	8	0	331
Total	42	336	23	0	42	3	184	0	16	536	12	0	53	10	25	0	1282

# Alliant Engineering Inc Minneapolis, MN 55415

TH-149 at Lone Oak Parkway  
Ref.Pt.: 003.613  
Alliant Engineering Inc  
TURN MOVEMENT COUNT

File Name : 16\_TH 149 at Lone Oak Pkwy\_022310  
Site Code : 00000016  
Start Date : 2/23/2010  
Page No : 2

### Groups Printed- Unshifted - Bank 1

Start Time	TH-149 / Dodd Rd Southbound				Lone Oak Parkway Westbound				TH-149 / Dodd Rd Northbound				commercial entrance Eastbound				Int. Total
	Left	Thru	Right	Peds	Left	Thru	Right	Peds	Left	Thru	Right	Peds	Left	Thru	Right	Peds	
16:00	16	103	11	0	10	3	79	0	7	170	7	0	21	1	12	0	440
16:15	12	111	5	0	9	1	70	0	3	156	3	0	7	0	11	0	388
16:30	11	111	6	0	27	1	76	0	7	171	3	0	30	2	11	0	456
16:45	2	117	1	0	22	5	54	0	7	169	5	0	13	3	6	0	404
Total	41	442	23	0	68	10	279	0	24	666	18	0	71	6	40	0	1688
17:00	3	105	4	0	12	6	90	0	9	222	5	0	14	2	8	0	480
17:15	3	135	15	0	5	2	50	0	7	160	4	0	19	0	11	0	411
17:30	4	108	8	0	13	1	42	1	6	130	4	0	17	2	8	0	344
17:45	4	104	6	0	8	0	33	0	2	133	3	0	11	0	5	0	309
Total	14	452	33	0	38	9	215	1	24	645	16	0	61	4	32	0	1544
Grand Total	900	3553	477	5	233	76	943	5	279	4541	294	1	327	88	306	0	12028
Apprch %	18.2	72	9.7	0.1	18.5	6	75	0.4	5.5	88.8	5.7	0	45.4	12.2	42.4	0	
Total %	7.5	29.5	4	0	1.9	0.6	7.8	0	2.3	37.8	2.4	0	2.7	0.7	2.5	0	
Unshifted	874	3390	470	5	224	72	928	5	274	4385	281	1	325	88	299	0	11621
% Unshifted	97.1	95.4	98.5	100	96.1	94.7	98.4	100	98.2	96.6	95.6	100	99.4	100	97.7	0	96.6
Bank 1	26	163	7	0	9	4	15	0	5	156	13	0	2	0	7	0	407
% Bank 1	2.9	4.6	1.5	0	3.9	5.3	1.6	0	1.8	3.4	4.4	0	0.6	0	2.3	0	3.4

# Alliant Engineering Inc Minneapolis, MN 55415

TH-149 at Lone Oak Parkway  
Ref.Pt.: 003.613  
Alliant Engineering Inc  
TURN MOVEMENT COUNT

File Name : 16\_TH 149 at Lone Oak Pkwy\_022310  
Site Code : 00000016  
Start Date : 2/23/2010  
Page No : 3

Start Time	TH-149 / Dodd Rd Southbound					Lone Oak Parkway Westbound					TH-149 / Dodd Rd Northbound					commercial entrance Eastbound					Int. Total
	Left	Thru	Right	Peds	App. Total	Left	Thru	Right	Peds	App. Total	Left	Thru	Right	Peds	App. Total	Left	Thru	Right	Peds	App. Total	
Peak Hour Analysis From 06:00 to 09:15 - Peak 1 of 1																					
Peak Hour for Entire Intersection Begins at 07:15																					
07:15	64	124	28	0	216	5	0	9	1	15	8	158	21	0	187	5	2	3	0	10	428
07:30	46	112	22	1	181	1	1	6	1	9	13	164	22	0	199	6	2	3	0	11	400
07:45	63	157	16	0	236	1	0	6	0	7	9	133	32	0	174	2	5	3	0	10	427
08:00	85	139	29	0	253	2	2	5	0	9	5	122	16	0	143	5	5	7	0	17	422
Total Volume	258	532	95	1	886	9	3	26	2	40	35	577	91	0	703	18	14	16	0	48	1677
% App. Total	29.1	60	10.7	0.1		22.5	7.5	65	5		5	82.1	12.9	0		37.5	29.2	33.3	0		
PHF	.759	.847	.819	.250	.875	.450	.375	.722	.500	.667	.673	.880	.711	.000	.883	.750	.700	.571	.000	.706	.980

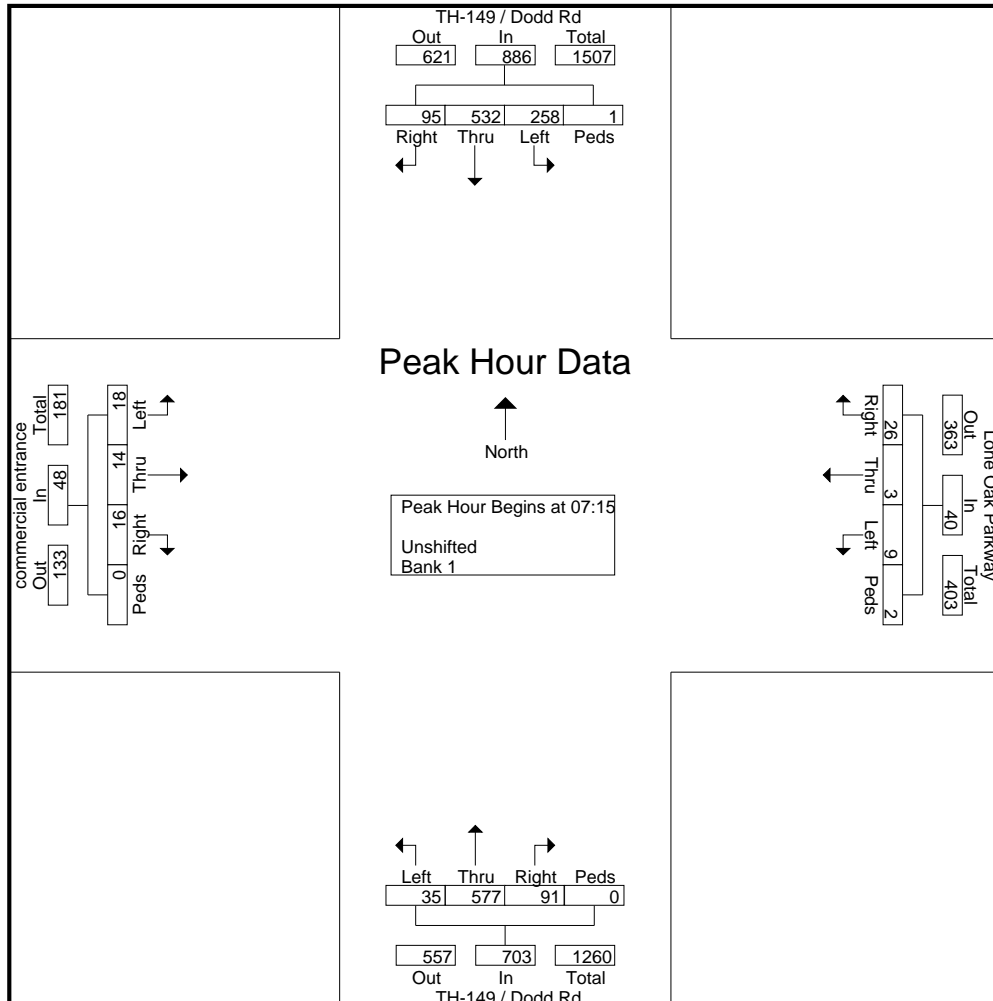

# Alliant Engineering Inc Minneapolis, MN 55415

TH-149 at Lone Oak Parkway  
Ref.Pt.: 003.613  
Alliant Engineering Inc  
TURN MOVEMENT COUNT

File Name : 16\_TH 149 at Lone Oak Pkwy\_022310  
Site Code : 00000016  
Start Date : 2/23/2010  
Page No : 4

Start Time	TH-149 / Dodd Rd Southbound					Lone Oak Parkway Westbound					TH-149 / Dodd Rd Northbound					commercial entrance Eastbound					Int. Total
	Left	Thru	Right	Peds	App. Total	Left	Thru	Right	Peds	App. Total	Left	Thru	Right	Peds	App. Total	Left	Thru	Right	Peds	App. Total	
Peak Hour Analysis From 15:00 to 17:45 - Peak 1 of 1																					
Peak Hour for Entire Intersection Begins at 16:30																					
16:30	11	111	6	0	128	27	1	76	0	104	7	171	3	0	181	30	2	11	0	43	456
16:45	2	117	1	0	120	22	5	54	0	81	7	169	5	0	181	13	3	6	0	22	404
17:00	3	105	4	0	112	12	6	90	0	108	9	222	5	0	236	14	2	8	0	24	480
17:15	3	135	15	0	153	5	2	50	0	57	7	160	4	0	171	19	0	11	0	30	411
Total Volume	19	468	26	0	513	66	14	270	0	350	30	722	17	0	769	76	7	36	0	119	1751
% App. Total	3.7	91.2	5.1	0		18.9	4	77.1	0		3.9	93.9	2.2	0		63.9	5.9	30.3	0		
PHF	.432	.867	.433	.000	.838	.611	.583	.750	.000	.810	.833	.813	.850	.000	.815	.633	.583	.818	.000	.692	.912

