



MINNESOTA DEPT OF TRANSPORTATION

TRAFFIC DATA COLLECTION - METRO

Lexington Ave at Co.Rd. B
 Ref.Pt.:
 JAMAR # 631 /xxx RE/CH
 TURN MOVEMENT COUNT

File Name : Lexington Ave at CoRd B 2010
 Site Code : 00000000
 Start Date : 3/9/2010
 Page No : 1

Groups Printed- Cars & Trucks

Start Time	Lexington Ave Southbound				Co.Rd. B Westbound				Lexington Ave Northbound				Co.Rd. B Eastbound				Int. Total
	Left	Thru	Right	Peds	Left	Thru	Right	Peds	Left	Thru	Right	Peds	Left	Thru	Right	Peds	
06:00	3	25	1	0	5	16	2	0	1	31	5	2	3	7	1	2	104
06:15	2	37	4	0	6	17	7	0	3	31	7	0	2	5	2	0	123
06:30	1	60	8	1	9	17	4	0	6	59	5	0	8	5	1	0	184
06:45	3	74	6	0	12	40	10	0	10	53	10	0	8	7	3	0	236
Total	9	196	19	1	32	90	23	0	20	174	27	2	21	24	7	2	647
07:00	4	100	11	0	9	39	6	1	3	80	10	0	9	7	5	0	284
07:15	8	105	14	1	9	49	31	3	24	105	4	2	7	14	9	0	385
07:30	8	131	16	1	19	109	29	0	17	102	9	0	24	25	6	0	496
07:45	15	111	18	0	16	100	24	0	24	103	5	4	7	19	5	0	451
Total	35	447	59	2	53	297	90	4	68	390	28	6	47	65	25	0	1616
08:00	7	102	14	0	17	58	14	1	15	90	8	0	13	16	2	0	357
08:15	2	83	13	0	14	39	10	1	13	76	9	0	11	10	3	0	284
08:30	4	74	8	0	12	42	9	0	10	92	13	0	10	12	7	0	293
08:45	7	98	19	1	17	37	6	0	14	88	14	0	14	29	15	0	359
Total	20	357	54	1	60	176	39	2	52	346	44	0	48	67	27	0	1293
*** BREAK ***																	
15:00	16	85	16	3	17	37	9	0	14	117	7	1	20	54	25	0	421
15:15	19	133	13	1	12	27	16	1	23	126	12	1	23	66	22	0	495
15:30	15	126	14	5	20	43	12	0	18	134	15	2	24	58	29	2	517
15:45	10	111	18	2	19	30	12	1	18	143	13	0	18	65	30	0	490
Total	60	455	61	11	68	137	49	2	73	520	47	4	85	243	106	2	1923
16:00	12	115	17	6	20	39	4	1	16	119	20	0	34	82	29	0	514
16:15	16	116	8	0	18	26	13	0	28	175	21	1	31	67	25	1	546
16:30	14	140	14	1	12	32	13	2	12	148	13	1	33	54	27	0	516
16:45	14	107	19	2	20	52	10	1	19	147	14	0	20	92	23	0	540
Total	56	478	58	9	70	149	40	4	75	589	68	2	118	295	104	1	2116
17:00	13	108	17	0	12	44	6	1	11	170	25	1	25	93	31	1	558
17:15	12	129	9	1	23	40	6	2	20	143	12	2	31	87	37	1	555
17:30	16	117	14	1	21	42	10	1	22	117	19	1	29	93	34	2	539
17:45	11	130	8	1	12	37	12	2	16	117	22	0	24	76	29	0	497
Total	52	484	48	3	68	163	34	6	69	547	78	4	109	349	131	4	2149
Grand Total	232	2417	299	27	351	1012	275	18	357	2566	292	18	428	1043	400	9	9744
Apprch %	7.8	81.2	10.1	0.9	21.2	61.1	16.6	1.1	11	79.4	9	0.6	22.8	55.5	21.3	0.5	
Total %	2.4	24.8	3.1	0.3	3.6	10.4	2.8	0.2	3.7	26.3	3	0.2	4.4	10.7	4.1	0.1	



MINNESOTA DEPT OF TRANSPORTATION

TRAFFIC DATA COLLECTION - METRO

Lexington Ave at Co.Rd. B
 Ref.Pt.:
 JAMAR # 631 /xxx RE/CH
 TURN MOVEMENT COUNT

File Name : Lexington Ave at CoRd B 2010
 Site Code : 00000000
 Start Date : 3/9/2010
 Page No : 2

Start Time	Lexington Ave Southbound					Co.Rd. B Westbound					Lexington Ave Northbound					Co.Rd. B Eastbound					Int. Total
	Left	Thru	Right	Peds	App. Total	Left	Thru	Right	Peds	App. Total	Left	Thru	Right	Peds	App. Total	Left	Thru	Right	Peds	App. Total	
Peak Hour Analysis From 06:00 to 08:45 - Peak 1 of 1																					
Peak Hour for Entire Intersection Begins at 07:15																					
07:15	8	105	14	1	128	9	49	31	3	92	24	105	4	2	135	7	14	9	0	30	385
07:30	8	131	16	1	156	19	109	29	0	157	17	102	9	0	128	24	25	6	0	55	496
07:45	15	111	18	0	144	16	100	24	0	140	24	103	5	4	136	7	19	5	0	31	451
08:00	7	102	14	0	123	17	58	14	1	90	15	90	8	0	113	13	16	2	0	31	357
Total Volume	38	449	62	2	551	61	316	98	4	479	80	400	26	6	512	51	74	22	0	147	1689
% App. Total	6.9	81.5	11.3	0.4		12.7	66	20.5	0.8		15.6	78.1	5.1	1.2		34.7	50.3	15	0		
PHF	.633	.857	.861	.500	.883	.803	.725	.790	.333	.763	.833	.952	.722	.375	.941	.531	.740	.611	.000	.668	.851

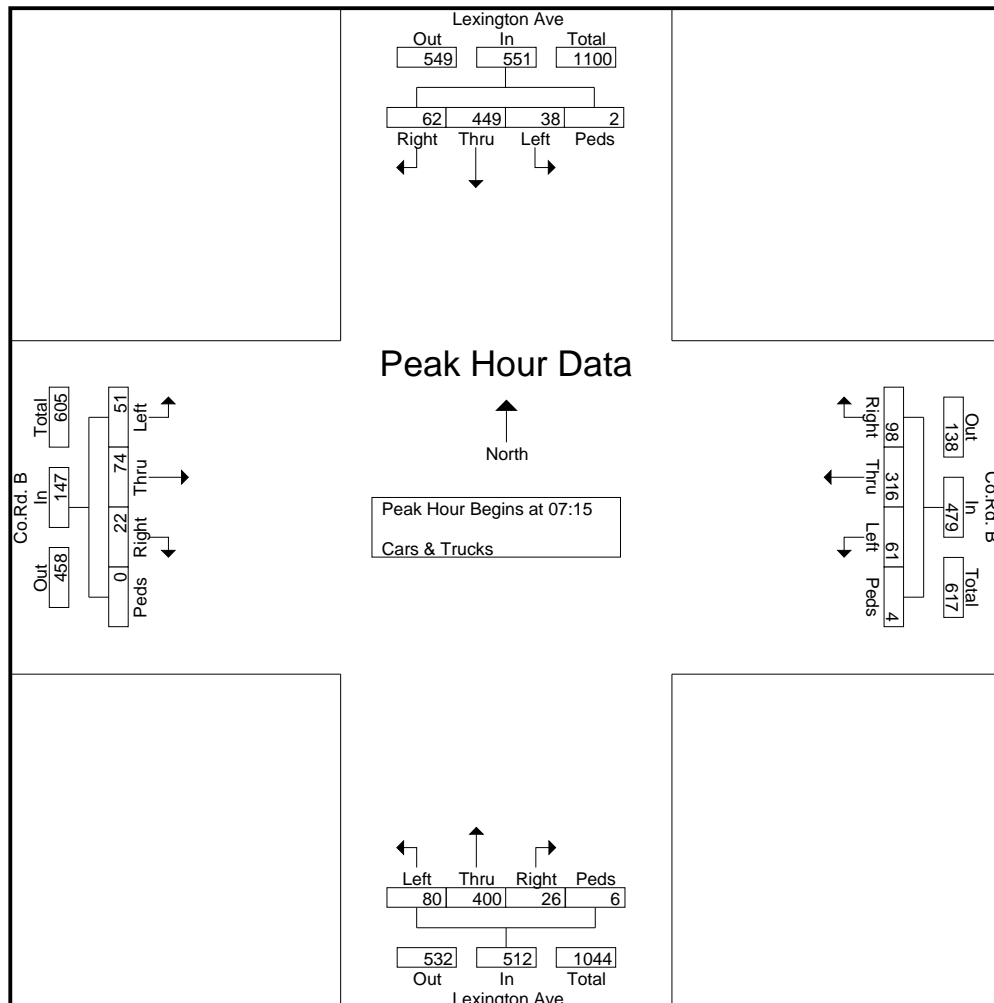



MINNESOTA DEPT OF TRANSPORTATION

TRAFFIC DATA COLLECTION - METRO

Lexington Ave at Co.Rd. B
 Ref.Pt.:
 JAMAR # 631 /xxx RE/CH
 TURN MOVEMENT COUNT

File Name : Lexington Ave at CoRd B 2010
 Site Code : 00000000
 Start Date : 3/9/2010
 Page No : 3

Start Time	Lexington Ave Southbound					Co.Rd. B Westbound					Lexington Ave Northbound					Co.Rd. B Eastbound					Int. Total
	Left	Thru	Right	Peds	App. Total	Left	Thru	Right	Peds	App. Total	Left	Thru	Right	Peds	App. Total	Left	Thru	Right	Peds	App. Total	

Peak Hour Analysis From 14:45 to 17:45 - Peak 1 of 1
 Peak Hour for Entire Intersection Begins at 16:45

16:45	14	107	19	2	142	20	52	10	1	83	19	147	14	0	180	20	92	23	0	135	540
17:00	13	108	17	0	138	12	44	6	1	63	11	170	25	1	207	25	93	31	1	150	558
17:15	12	129	9	1	151	23	40	6	2	71	20	143	12	2	177	31	87	37	1	156	555
17:30	16	117	14	1	148	21	42	10	1	74	22	117	19	1	159	29	93	34	2	158	539
Total Volume	55	461	59	4	579	76	178	32	5	291	72	577	70	4	723	105	365	125	4	599	2192
% App. Total	9.5	79.6	10.2	0.7		26.1	61.2	11	1.7		10	79.8	9.7	0.6		17.5	60.9	20.9	0.7		
PHF	.859	.893	.776	.500	.959	.826	.856	.800	.625	.877	.818	.849	.700	.500	.873	.847	.981	.845	.500	.948	.982

