

Alliant Engineering, Inc

733 Marquette Ave, Ste 700

Minneapolis, MN 55402

--TRAFFIC DATA--

Curve Crest Blvd & Market Dr
 No Ref Point
 Data by: Alliant Engineering, Inc.
 TURN MOVEMENT COUNT

File Name : 708_Curve Crest Blvd & Market Dr
 Site Code : 708
 Start Date : 5/16/2018
 Page No : 1

Groups Printed- Cars - Trucks

| Start Time | Market Dr Southbound | | | | | Curve Crest Blvd Westbound | | | | | Market Dr Northbound | | | | | Curve Crest Blvd Eastbound | | | | | Int. Total |
|---------------|----------------------|-------|------|------|------------|----------------------------|-------|------|------|------------|----------------------|-------|------|------|------------|----------------------------|-------|------|------|------------|------------|
| | Peds | Right | Thru | Left | App. Total | Peds | Right | Thru | Left | App. Total | Peds | Right | Thru | Left | App. Total | Peds | Right | Thru | Left | App. Total | |
| 06:00 AM | 0 | 5 | 5 | 2 | 12 | 0 | 4 | 6 | 0 | 10 | 0 | 1 | 1 | 6 | 8 | 0 | 5 | 6 | 3 | 14 | 44 |
| 06:15 AM | 0 | 11 | 4 | 4 | 19 | 0 | 2 | 6 | 1 | 9 | 0 | 1 | 1 | 8 | 10 | 0 | 10 | 15 | 3 | 28 | 66 |
| 06:30 AM | 0 | 7 | 1 | 4 | 12 | 1 | 6 | 8 | 2 | 17 | 0 | 1 | 1 | 13 | 15 | 1 | 17 | 15 | 6 | 39 | 83 |
| 06:45 AM | 0 | 14 | 6 | 3 | 23 | 0 | 0 | 5 | 4 | 9 | 0 | 7 | 2 | 11 | 20 | 0 | 15 | 29 | 4 | 48 | 100 |
| Total | 0 | 37 | 16 | 13 | 66 | 1 | 12 | 25 | 7 | 45 | 0 | 10 | 5 | 38 | 53 | 1 | 47 | 65 | 16 | 129 | 293 |
| 07:00 AM | 0 | 17 | 3 | 4 | 24 | 0 | 2 | 7 | 4 | 13 | 0 | 4 | 3 | 16 | 23 | 0 | 26 | 20 | 8 | 54 | 114 |
| 07:15 AM | 0 | 19 | 1 | 6 | 26 | 0 | 8 | 15 | 1 | 24 | 0 | 3 | 4 | 15 | 22 | 0 | 16 | 30 | 5 | 51 | 123 |
| 07:30 AM | 0 | 8 | 3 | 4 | 15 | 0 | 6 | 19 | 5 | 30 | 0 | 6 | 3 | 16 | 25 | 0 | 34 | 40 | 8 | 82 | 152 |
| 07:45 AM | 0 | 18 | 3 | 5 | 26 | 0 | 8 | 15 | 10 | 33 | 0 | 6 | 4 | 17 | 27 | 0 | 26 | 42 | 6 | 74 | 160 |
| Total | 0 | 62 | 10 | 19 | 91 | 0 | 24 | 56 | 20 | 100 | 0 | 19 | 14 | 64 | 97 | 0 | 102 | 132 | 27 | 261 | 549 |
| 08:00 AM | 0 | 18 | 4 | 8 | 30 | 0 | 12 | 15 | 3 | 30 | 0 | 7 | 5 | 18 | 30 | 0 | 39 | 35 | 9 | 83 | 173 |
| 08:15 AM | 1 | 13 | 9 | 5 | 28 | 0 | 9 | 17 | 4 | 30 | 1 | 2 | 5 | 19 | 27 | 0 | 33 | 37 | 8 | 78 | 163 |
| 08:30 AM | 0 | 7 | 8 | 7 | 22 | 1 | 10 | 26 | 3 | 40 | 0 | 2 | 7 | 29 | 38 | 1 | 50 | 38 | 8 | 97 | 197 |
| 08:45 AM | 0 | 15 | 10 | 10 | 35 | 0 | 15 | 19 | 13 | 47 | 0 | 10 | 10 | 25 | 45 | 0 | 46 | 39 | 14 | 99 | 226 |
| Total | 1 | 53 | 31 | 30 | 115 | 1 | 46 | 77 | 23 | 147 | 1 | 21 | 27 | 91 | 140 | 1 | 168 | 149 | 39 | 357 | 759 |
| 09:00 AM | 0 | 8 | 11 | 8 | 27 | 0 | 12 | 24 | 4 | 40 | 0 | 15 | 11 | 38 | 64 | 0 | 46 | 40 | 10 | 96 | 227 |
| 09:15 AM | 0 | 13 | 10 | 11 | 34 | 2 | 13 | 18 | 6 | 39 | 0 | 8 | 9 | 36 | 53 | 2 | 37 | 41 | 8 | 88 | 214 |
| *** BREAK *** | | | | | | | | | | | | | | | | | | | | | |
| Total | 0 | 21 | 21 | 19 | 61 | 2 | 25 | 42 | 10 | 79 | 0 | 23 | 20 | 74 | 117 | 2 | 83 | 81 | 18 | 184 | 441 |
| *** BREAK *** | | | | | | | | | | | | | | | | | | | | | |
| 10:30 AM | 0 | 20 | 14 | 16 | 50 | 2 | 17 | 29 | 10 | 58 | 0 | 11 | 20 | 37 | 68 | 2 | 37 | 32 | 5 | 76 | 252 |
| 10:45 AM | 0 | 13 | 7 | 7 | 27 | 0 | 25 | 21 | 8 | 54 | 0 | 11 | 11 | 34 | 56 | 0 | 48 | 41 | 9 | 98 | 235 |
| Total | 0 | 33 | 21 | 23 | 77 | 2 | 42 | 50 | 18 | 112 | 0 | 22 | 31 | 71 | 124 | 2 | 85 | 73 | 14 | 174 | 487 |
| 11:00 AM | 0 | 13 | 11 | 10 | 34 | 2 | 10 | 34 | 9 | 55 | 2 | 7 | 14 | 45 | 68 | 2 | 36 | 18 | 14 | 70 | 227 |
| 11:15 AM | 0 | 8 | 10 | 10 | 28 | 0 | 14 | 39 | 7 | 60 | 0 | 11 | 20 | 40 | 71 | 0 | 41 | 41 | 6 | 88 | 247 |
| 11:30 AM | 0 | 15 | 11 | 16 | 42 | 2 | 15 | 34 | 3 | 54 | 0 | 11 | 12 | 38 | 61 | 2 | 44 | 35 | 11 | 92 | 249 |
| 11:45 AM | 0 | 17 | 9 | 10 | 36 | 0 | 22 | 47 | 9 | 78 | 0 | 10 | 17 | 34 | 61 | 0 | 47 | 37 | 19 | 103 | 278 |
| Total | 0 | 53 | 41 | 46 | 140 | 4 | 61 | 154 | 28 | 247 | 2 | 39 | 63 | 157 | 261 | 4 | 168 | 131 | 50 | 353 | 1001 |
| 12:00 PM | 0 | 15 | 13 | 7 | 35 | 2 | 15 | 47 | 12 | 76 | 1 | 9 | 16 | 49 | 75 | 2 | 65 | 32 | 19 | 118 | 304 |
| 12:15 PM | 0 | 19 | 13 | 13 | 45 | 0 | 20 | 30 | 14 | 64 | 0 | 20 | 20 | 50 | 90 | 0 | 40 | 30 | 19 | 89 | 288 |
| 12:30 PM | 0 | 16 | 15 | 14 | 45 | 0 | 19 | 41 | 14 | 74 | 0 | 20 | 27 | 35 | 82 | 0 | 42 | 36 | 13 | 91 | 292 |
| 12:45 PM | 0 | 18 | 7 | 15 | 40 | 2 | 20 | 41 | 6 | 69 | 0 | 15 | 22 | 51 | 88 | 3 | 39 | 41 | 12 | 95 | 292 |
| Total | 0 | 68 | 48 | 49 | 165 | 4 | 74 | 159 | 46 | 283 | 1 | 64 | 85 | 185 | 335 | 5 | 186 | 139 | 63 | 393 | 1176 |
| 01:00 PM | 0 | 13 | 10 | 10 | 33 | 2 | 17 | 31 | 11 | 61 | 0 | 12 | 16 | 45 | 73 | 2 | 46 | 43 | 10 | 101 | 268 |
| 01:15 PM | 0 | 25 | 10 | 7 | 42 | 0 | 14 | 31 | 7 | 52 | 0 | 8 | 11 | 46 | 65 | 0 | 50 | 40 | 13 | 103 | 262 |
| *** BREAK *** | | | | | | | | | | | | | | | | | | | | | |
| Total | 0 | 38 | 20 | 17 | 75 | 2 | 31 | 62 | 18 | 113 | 0 | 20 | 27 | 91 | 138 | 2 | 96 | 83 | 23 | 204 | 530 |
| *** BREAK *** | | | | | | | | | | | | | | | | | | | | | |
| 02:30 PM | 0 | 18 | 7 | 11 | 36 | 1 | 22 | 48 | 16 | 87 | 0 | 9 | 17 | 31 | 57 | 1 | 48 | 37 | 11 | 97 | 277 |
| 02:45 PM | 1 | 6 | 6 | 8 | 21 | 1 | 12 | 34 | 4 | 51 | 0 | 15 | 17 | 51 | 83 | 0 | 54 | 40 | 13 | 107 | 262 |
| Total | 1 | 24 | 13 | 19 | 57 | 2 | 34 | 82 | 20 | 138 | 0 | 24 | 34 | 82 | 140 | 1 | 102 | 77 | 24 | 204 | 539 |
| 03:00 PM | 1 | 33 | 12 | 12 | 58 | 1 | 16 | 47 | 7 | 71 | 0 | 21 | 8 | 43 | 72 | 1 | 50 | 49 | 19 | 119 | 320 |
| 03:15 PM | 1 | 10 | 18 | 11 | 40 | 0 | 21 | 41 | 6 | 68 | 0 | 17 | 21 | 45 | 83 | 0 | 43 | 36 | 10 | 89 | 280 |

Alliant Engineering, Inc

733 Marquette Ave, Ste 700

Minneapolis, MN 55402

--TRAFFIC DATA--

File Name : 708_Curve Crest Blvd & Market Dr

Site Code : 708

Start Date : 5/16/2018

Page No : 2

Groups Printed- Cars - Trucks

| Start Time | Market Dr Southbound | | | | | Curve Crest Blvd Westbound | | | | | Market Dr Northbound | | | | | Curve Crest Blvd Eastbound | | | | | Int. Total |
|---------------|----------------------|-------|------|------|------------|----------------------------|-------|------|------|------------|----------------------|-------|------|------|------------|----------------------------|-------|------|------|------------|------------|
| | Peds | Right | Thru | Left | App. Total | Peds | Right | Thru | Left | App. Total | Peds | Right | Thru | Left | App. Total | Peds | Right | Thru | Left | App. Total | |
| 03:30 PM | 0 | 11 | 4 | 10 | 25 | 0 | 18 | 54 | 3 | 75 | 0 | 10 | 11 | 56 | 77 | 0 | 63 | 31 | 9 | 103 | 280 |
| 03:45 PM | 1 | 15 | 16 | 7 | 39 | 1 | 16 | 55 | 11 | 83 | 0 | 18 | 16 | 57 | 91 | 1 | 73 | 42 | 8 | 124 | 337 |
| Total | 3 | 69 | 50 | 40 | 162 | 2 | 71 | 197 | 27 | 297 | 0 | 66 | 56 | 201 | 323 | 2 | 229 | 158 | 46 | 435 | 1217 |
| 04:00 PM | 0 | 11 | 13 | 14 | 38 | 0 | 18 | 40 | 5 | 63 | 0 | 18 | 21 | 64 | 103 | 0 | 55 | 33 | 7 | 95 | 299 |
| 04:15 PM | 0 | 14 | 10 | 12 | 36 | 1 | 18 | 59 | 7 | 85 | 0 | 11 | 27 | 58 | 96 | 0 | 63 | 51 | 11 | 125 | 342 |
| 04:30 PM | 0 | 9 | 3 | 12 | 24 | 0 | 11 | 53 | 9 | 73 | 0 | 13 | 25 | 49 | 87 | 0 | 68 | 45 | 14 | 127 | 311 |
| 04:45 PM | 0 | 16 | 11 | 8 | 35 | 1 | 16 | 42 | 10 | 69 | 0 | 20 | 17 | 60 | 97 | 0 | 71 | 41 | 11 | 123 | 324 |
| Total | 0 | 50 | 37 | 46 | 133 | 2 | 63 | 194 | 31 | 290 | 0 | 62 | 90 | 231 | 383 | 0 | 257 | 170 | 43 | 470 | 1276 |
| 05:00 PM | 0 | 7 | 11 | 12 | 30 | 0 | 12 | 61 | 4 | 77 | 0 | 22 | 18 | 78 | 118 | 0 | 62 | 47 | 11 | 120 | 345 |
| 05:15 PM | 0 | 13 | 10 | 10 | 33 | 0 | 26 | 39 | 6 | 71 | 0 | 16 | 17 | 54 | 87 | 1 | 63 | 46 | 12 | 122 | 313 |
| 05:30 PM | 0 | 11 | 10 | 9 | 30 | 0 | 20 | 40 | 10 | 70 | 0 | 20 | 23 | 46 | 89 | 0 | 49 | 39 | 7 | 95 | 284 |
| 05:45 PM | 0 | 10 | 9 | 12 | 31 | 0 | 15 | 35 | 6 | 56 | 0 | 10 | 25 | 47 | 82 | 0 | 58 | 27 | 13 | 98 | 267 |
| Total | 0 | 41 | 40 | 43 | 124 | 0 | 73 | 175 | 26 | 274 | 0 | 68 | 83 | 225 | 376 | 1 | 232 | 159 | 43 | 435 | 1209 |
| *** BREAK *** | | | | | | | | | | | | | | | | | | | | | |
| Grand Total | 5 | 549 | 348 | 364 | 1266 | 22 | 556 | 1273 | 274 | 2125 | 4 | 438 | 535 | 1510 | 2487 | 21 | 1755 | 1417 | 406 | 3599 | 9477 |
| Apprch % | 0.4 | 43.4 | 27.5 | 28.8 | | 1 | 26.2 | 59.9 | 12.9 | | 0.2 | 17.6 | 21.5 | 60.7 | | 0.6 | 48.8 | 39.4 | 11.3 | | |
| Total % | 0.1 | 5.8 | 3.7 | 3.8 | 13.4 | 0.2 | 5.9 | 13.4 | 2.9 | 22.4 | 0 | 4.6 | 5.6 | 15.9 | 26.2 | 0.2 | 18.5 | 15 | 4.3 | 38 | |
| Cars | 5 | 536 | 340 | 358 | 1239 | 22 | 545 | 1221 | 273 | 2061 | 4 | 431 | 530 | 1479 | 2444 | 21 | 1719 | 1378 | 391 | 3509 | 9253 |
| % Cars | 100 | 97.6 | 97.7 | 98.4 | 97.9 | 100 | 98 | 95.9 | 99.6 | 97 | 100 | 98.4 | 99.1 | 97.9 | 98.3 | 100 | 97.9 | 97.2 | 96.3 | 97.5 | 97.6 |
| Trucks | 0 | 13 | 8 | 6 | 27 | 0 | 11 | 52 | 1 | 64 | 0 | 7 | 5 | 31 | 43 | 0 | 36 | 39 | 15 | 90 | 224 |
| % Trucks | 0 | 2.4 | 2.3 | 1.6 | 2.1 | 0 | 2 | 4.1 | 0.4 | 3 | 0 | 1.6 | 0.9 | 2.1 | 1.7 | 0 | 2.1 | 2.8 | 3.7 | 2.5 | 2.4 |

Alliant Engineering, Inc

733 Marquette Ave, Ste 700

Minneapolis, MN 55402

--TRAFFIC DATA--

File Name : 708_Curve Crest Blvd & Market Dr

Site Code : 708

Start Date : 5/16/2018

Page No : 3

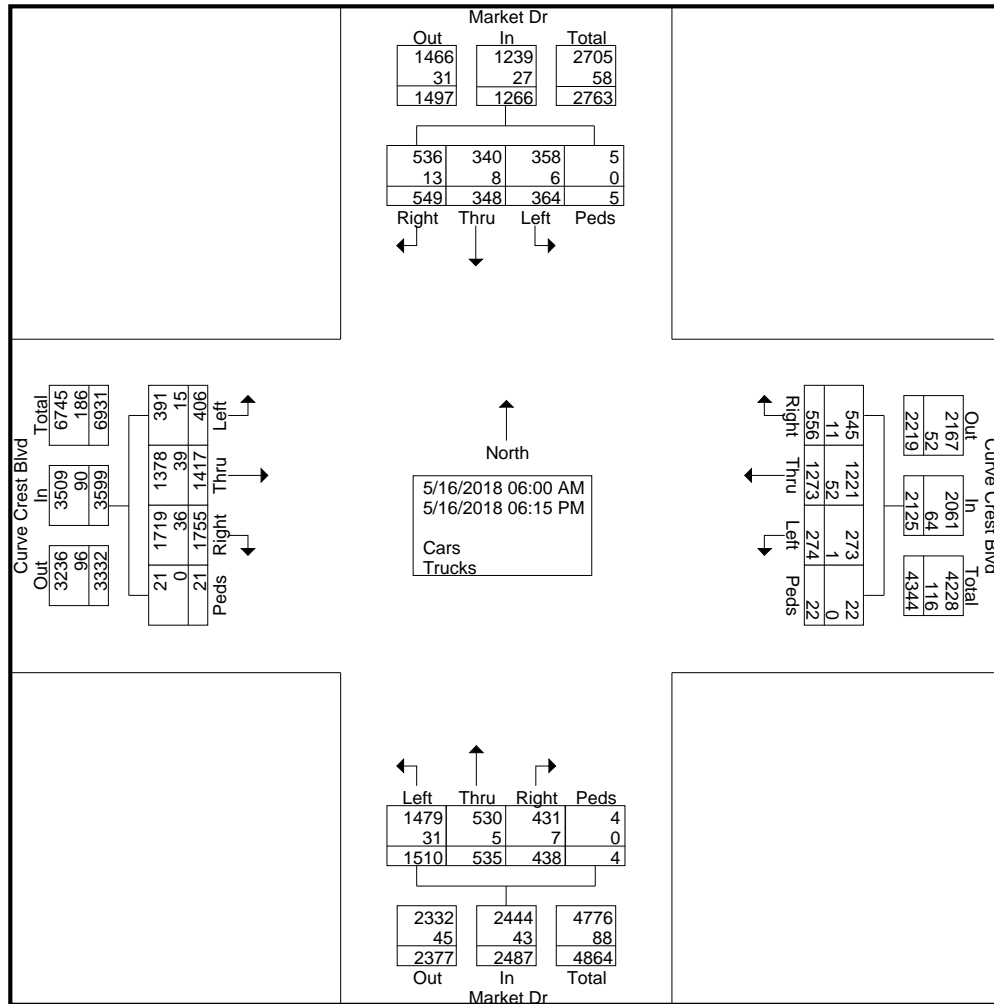

| Start Time | Market Dr Southbound | | | | | Curve Crest Blvd Westbound | | | | | Market Dr Northbound | | | | | Curve Crest Blvd Eastbound | | | | | Int. Total |
|--|----------------------|-------|------|------|------------|----------------------------|-------|------|------|------------|----------------------|-------|------|------|------------|----------------------------|-------|------|------|------------|------------|
| | Peds | Right | Thru | Left | App. Total | Peds | Right | Thru | Left | App. Total | Peds | Right | Thru | Left | App. Total | Peds | Right | Thru | Left | App. Total | |
| Peak Hour Analysis From 06:00 AM to 11:45 AM - Peak 1 of 1 | | | | | | | | | | | | | | | | | | | | | |
| Peak Hour for Entire Intersection Begins at 11:00 AM | | | | | | | | | | | | | | | | | | | | | |
| 11:00 AM | 0 | 13 | 11 | 10 | 34 | 2 | 10 | 34 | 9 | 55 | 2 | 7 | 14 | 45 | 68 | 2 | 36 | 18 | 14 | 70 | 227 |
| 11:15 AM | 0 | 8 | 10 | 10 | 28 | 0 | 14 | 39 | 7 | 60 | 0 | 11 | 20 | 40 | 71 | 0 | 41 | 41 | 6 | 88 | 247 |
| 11:30 AM | 0 | 15 | 11 | 16 | 42 | 2 | 15 | 34 | 3 | 54 | 0 | 11 | 12 | 38 | 61 | 2 | 44 | 35 | 11 | 92 | 249 |
| 11:45 AM | 0 | 17 | 9 | 10 | 36 | 0 | 22 | 47 | 9 | 78 | 0 | 10 | 17 | 34 | 61 | 0 | 47 | 37 | 19 | 103 | 278 |
| Total Volume | 0 | 53 | 41 | 46 | 140 | 4 | 61 | 154 | 28 | 247 | 2 | 39 | 63 | 157 | 261 | 4 | 168 | 131 | 50 | 353 | 1001 |
| % App. Total | 0 | 37.9 | 29.3 | 32.9 | | 1.6 | 24.7 | 62.3 | 11.3 | | 0.8 | 14.9 | 24.1 | 60.2 | | 1.1 | 47.6 | 37.1 | 14.2 | | |
| PHF | .000 | .779 | .932 | .719 | .833 | .500 | .693 | .819 | .778 | .792 | .250 | .886 | .788 | .872 | .919 | .500 | .894 | .799 | .658 | .857 | .900 |

Alliant Engineering, Inc

733 Marquette Ave, Ste 700

Minneapolis, MN 55402

--TRAFFIC DATA--

File Name : 708_Curve Crest Blvd & Market Dr

Site Code : 708

Start Date : 5/16/2018

Page No : 4

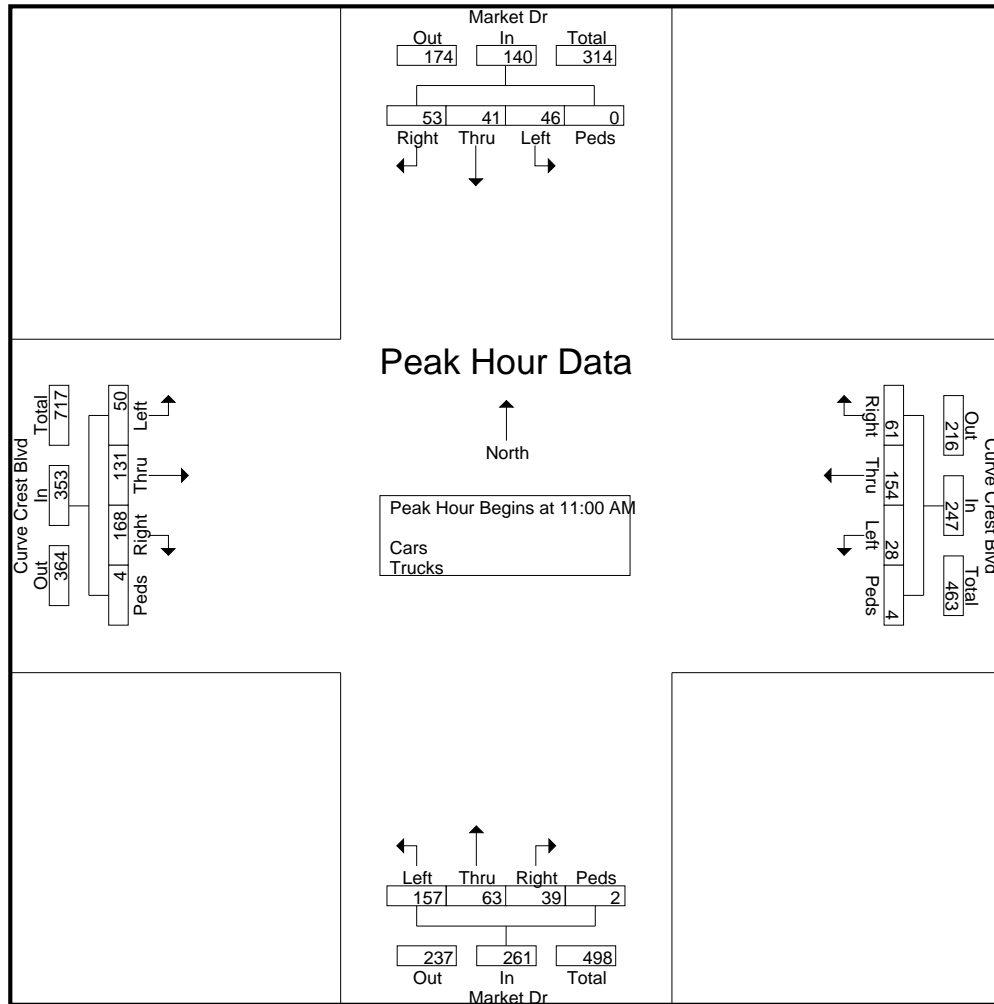

Peak Hour Analysis From 12:00 PM to 06:15 PM - Peak 1 of 1

Peak Hour for Entire Intersection Begins at 04:15 PM

| | | | | | | | | | | | | | | | | | | | | | |
|--------------|------|------|------|------|------|------|------|------|------|------|------|------|------|------|------|------|------|------|------|------|------|
| 04:15 PM | 0 | 14 | 10 | 12 | 36 | 1 | 18 | 59 | 7 | 85 | 0 | 11 | 27 | 58 | 96 | 0 | 63 | 51 | 11 | 125 | 342 |
| 04:30 PM | 0 | 9 | 3 | 12 | 24 | 0 | 11 | 53 | 9 | 73 | 0 | 13 | 25 | 49 | 87 | 0 | 68 | 45 | 14 | 127 | 311 |
| 04:45 PM | 0 | 16 | 11 | 8 | 35 | 1 | 16 | 42 | 10 | 69 | 0 | 20 | 17 | 60 | 97 | 0 | 71 | 41 | 11 | 123 | 324 |
| 05:00 PM | 0 | 7 | 11 | 12 | 30 | 0 | 12 | 61 | 4 | 77 | 0 | 22 | 18 | 78 | 118 | 0 | 62 | 47 | 11 | 120 | 345 |
| Total Volume | 0 | 46 | 35 | 44 | 125 | 2 | 57 | 215 | 30 | 304 | 0 | 66 | 87 | 245 | 398 | 0 | 264 | 184 | 47 | 495 | 1322 |
| % App. Total | 0 | 36.8 | 28 | 35.2 | | 0.7 | 18.8 | 70.7 | 9.9 | | 0 | 16.6 | 21.9 | 61.6 | | 0 | 53.3 | 37.2 | 9.5 | | |
| PHF | .000 | .719 | .795 | .917 | .868 | .500 | .792 | .881 | .750 | .894 | .000 | .750 | .806 | .785 | .843 | .000 | .930 | .902 | .839 | .974 | .958 |

Alliant Engineering, Inc

733 Marquette Ave, Ste 700

Minneapolis, MN 55402

--TRAFFIC DATA--

File Name : 708_Curve Crest Blvd & Market Dr

Site Code : 708

Start Date : 5/16/2018

Page No : 5

