

Albeck Gerken, Inc

Transportation Engineers

Traffic Data Collection

TH-47 / University Ave at 57th Ave NE

Ref.Pt.: 007.868

Data by: Albeck Gerkin Inc

TURN MOVEMENT COUNT

File Name : TH-47 at 57th Ave NE 2008

Site Code : 01828182

Start Date : 7/15/2008

Page No : 1

Groups Printed- Unshifted

Start Time	TH-47 / University Avenue Southbound				57th Avenue NE Westbound				TH-47 / University Avenue Northbound				57th Avenue NE Eastbound				Int. Total
	Left	Thru	Right	Peds	Left	Thru	Right	Peds	Left	Thru	Right	Peds	Left	Thru	Right	Peds	
06:00	8	223	27	0	30	4	8	0	30	96	14	0	7	3	40	0	490
06:15	7	218	26	2	26	8	6	0	22	114	17	1	8	4	57	0	516
06:30	14	425	33	0	25	11	7	0	39	152	22	4	6	3	62	0	803
06:45	7	315	34	3	32	10	8	1	55	178	21	1	6	4	40	1	716
Total	36	1181	120	5	113	33	29	1	146	540	74	6	27	14	199	1	2525
07:00	6	395	32	2	27	1	7	0	42	128	20	1	14	3	38	0	716
07:15	13	392	34	2	28	8	6	0	20	148	27	2	13	5	50	2	750
07:30	19	383	26	1	27	6	8	0	41	157	24	6	16	3	50	0	767
07:45	25	390	35	2	32	12	10	0	31	179	59	1	13	7	47	0	843
Total	63	1560	127	7	114	27	31	0	134	612	130	10	56	18	185	2	3076
08:00	21	341	23	1	22	16	10	0	39	142	38	3	13	6	55	0	730
08:15	14	281	13	1	24	53	4	1	41	158	30	2	14	5	48	0	689
08:30	14	235	23	3	21	11	9	0	32	148	28	1	14	13	48	1	601
08:45	6	165	30	0	24	11	5	0	57	189	19	0	29	7	54	0	596
Total	55	1022	89	5	91	91	28	1	169	637	115	6	70	31	205	1	2616
*** BREAK ***																	
11:00	10	169	27	5	8	7	7	0	66	177	18	0	19	8	52	1	574
11:15	6	210	38	6	16	19	7	0	60	177	17	4	20	12	81	0	673
11:30	7	192	30	5	11	15	5	2	95	206	18	3	27	5	74	0	695
11:45	6	190	44	1	12	16	4	2	67	187	21	3	26	15	71	0	665
Total	29	761	139	17	47	57	23	4	288	747	74	10	92	40	278	1	2607
12:00	14	191	53	5	10	20	3	1	75	183	23	4	31	21	90	0	724
12:15	6	188	31	0	24	14	10	0	86	174	18	3	36	18	98	0	706
12:30	11	204	35	7	22	11	5	1	79	239	26	0	42	14	81	0	777
12:45	12	177	37	2	25	23	9	0	77	214	20	0	24	17	80	1	718
Total	43	760	156	14	81	68	27	2	317	810	87	7	133	70	349	1	2925
*** BREAK ***																	
15:00	9	207	40	6	20	16	8	0	55	298	26	0	51	18	81	0	835
15:15	9	188	24	4	11	20	10	2	67	318	26	3	31	13	96	0	822
15:30	10	248	34	2	15	14	20	0	49	283	29	2	64	21	108	1	900
15:45	4	227	33	2	17	13	10	2	44	356	39	0	35	20	75	0	877
Total	32	870	131	14	63	63	48	4	215	1255	120	5	181	72	360	1	3434
16:00	8	191	30	8	17	15	5	2	72	358	34	1	45	23	60	0	869
16:15	8	224	30	3	18	16	13	1	51	360	30	3	38	26	65	0	886
16:30	10	228	24	0	10	13	13	0	78	409	28	0	43	13	71	0	940
16:45	7	232	33	5	28	16	7	2	58	377	32	2	29	28	77	5	938
Total	33	875	117	16	73	60	38	5	259	1504	124	6	155	90	273	5	3633
17:00	18	216	33	4	29	11	12	0	64	315	36	0	36	26	84	0	884
17:15	7	213	25	2	22	16	18	3	76	421	27	4	35	20	88	0	977
17:30	15	181	36	3	29	13	9	0	58	364	50	2	30	31	51	2	874
17:45	6	170	25	2	21	13	9	0	56	408	38	2	33	14	46	1	844
Total	46	780	119	11	101	53	48	3	254	1508	151	8	134	91	269	3	3579
Grand Total	337	7809	998	89	683	452	272	20	1782	7613	875	58	848	426	2118	15	24395
Apprch %	3.6	84.6	10.8	1	47.9	31.7	19.1	1.4	17.3	73.7	8.5	0.6	24.9	12.5	62.2	0.4	
Total %	1.4	32	4.1	0.4	2.8	1.9	1.1	0.1	7.3	31.2	3.6	0.2	3.5	1.7	8.7	0.1	

Albeck Gerken, Inc

Transportation Engineers

Traffic Data Collection

TH-47 / University Ave at 57th Ave NE

Ref.Pt.: 007.868

Data by: Albeck Gerkin Inc

TURN MOVEMENT COUNT

File Name : TH-47 at 57th Ave NE 2008

Site Code : 01828182

Start Date : 7/15/2008

Page No : 2

Start Time	TH-47 / University Avenue Southbound					57th Avenue NE Westbound					TH-47 / University Avenue Northbound					57th Avenue NE Eastbound					Int. Total
	Left	Thru	Right	Peds	App. Total	Left	Thru	Right	Peds	App. Total	Left	Thru	Right	Peds	App. Total	Left	Thru	Right	Peds	App. Total	
Peak Hour Analysis From 06:00 to 08:45 - Peak 1 of 1																					
Peak Hour for Entire Intersection Begins at 07:15																					
07:15	13	392	34	2	441	28	8	6	0	42	20	148	27	2	197	13	5	50	2	70	750
07:30	19	383	26	1	429	27	6	8	0	41	41	157	24	6	228	16	3	50	0	69	767
07:45	25	390	35	2	452	32	12	10	0	54	31	179	59	1	270	13	7	47	0	67	843
08:00	21	341	23	1	386	22	16	10	0	48	39	142	38	3	222	13	6	55	0	74	730
Total Volume	78	1506	118	6	1708	109	42	34	0	185	131	626	148	12	917	55	21	202	2	280	3090
% App. Total	4.6	88.2	6.9	0.4		58.9	22.7	18.4	0		14.3	68.3	16.1	1.3		19.6	7.5	72.1	0.7		
PHF	.780	.960	.843	.750	.945	.852	.656	.850	.000	.856	.799	.874	.627	.500	.849	.859	.750	.918	.250	.946	.916

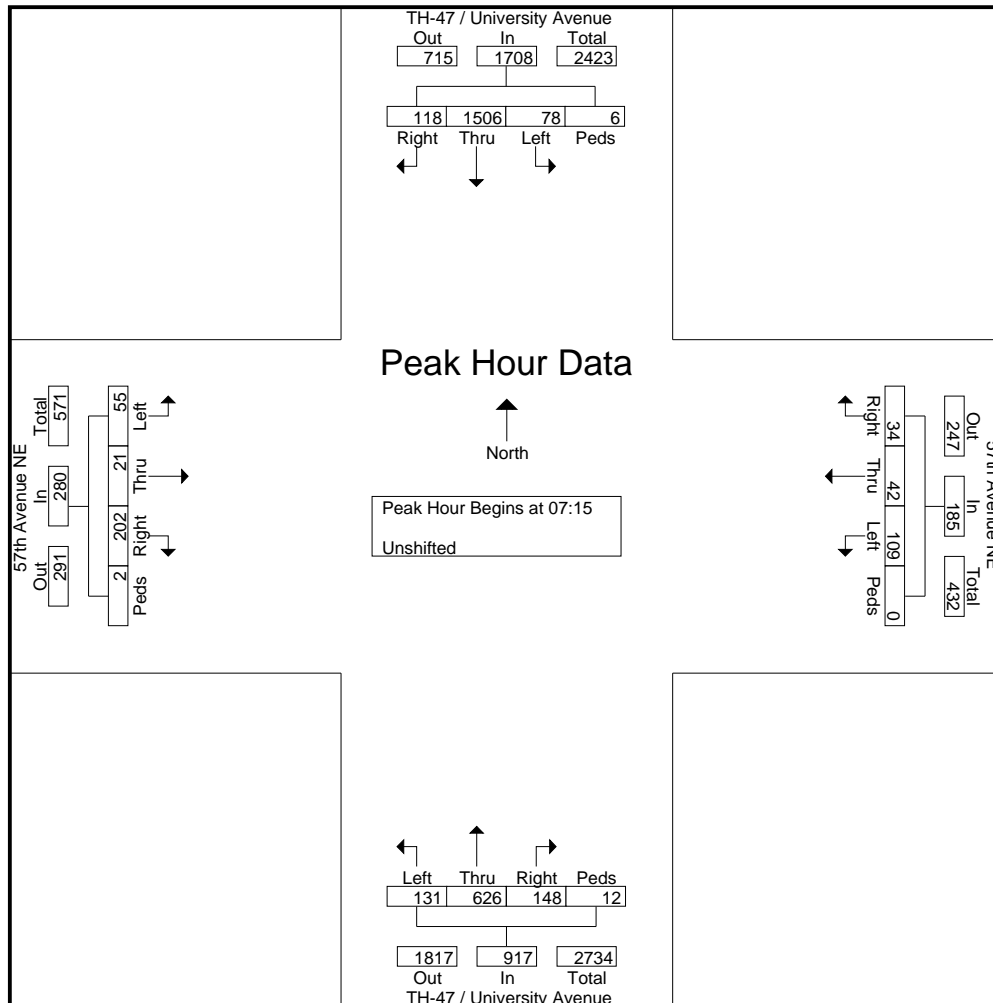

Albeck Gerken, Inc

Transportation Engineers

Traffic Data Collection

TH-47 / University Ave at 57th Ave NE

Ref.Pt.: 007.868

Data by: Albeck Gerkin Inc

TURN MOVEMENT COUNT

File Name : TH-47 at 57th Ave NE 2008

Site Code : 01828182

Start Date : 7/15/2008

Page No : 3

Start Time	TH-47 / University Avenue Southbound					57th Avenue NE Westbound					TH-47 / University Avenue Northbound					57th Avenue NE Eastbound					Int. Total
	Left	Thru	Right	Peds	App. Total	Left	Thru	Right	Peds	App. Total	Left	Thru	Right	Peds	App. Total	Left	Thru	Right	Peds	App. Total	
Peak Hour Analysis From 15:00 to 17:45 - Peak 1 of 1																					
Peak Hour for Entire Intersection Begins at 16:30																					
16:30	10	228	24	0	262	10	13	13	0	36	78	409	28	0	515	43	13	71	0	127	940
16:45	7	232	33	5	277	28	16	7	2	53	58	377	32	2	469	29	28	77	5	139	938
17:00	18	216	33	4	271	29	11	12	0	52	64	315	36	0	415	36	26	84	0	146	884
17:15	7	213	25	2	247	22	16	18	3	59	76	421	27	4	528	35	20	88	0	143	977
Total Volume	42	889	115	11	1057	89	56	50	5	200	276	1522	123	6	1927	143	87	320	5	555	3739
% App. Total	4	84.1	10.9	1		44.5	28	25	2.5		14.3	79	6.4	0.3		25.8	15.7	57.7	0.9		
PHF	.583	.958	.871	.550	.954	.767	.875	.694	.417	.847	.885	.904	.854	.375	.912	.831	.777	.909	.250	.950	.957

