

Associated Consulting Services (ACS)

Saint Paul, MN 55127

-- TRAFFIC DATA --

Location: TH-47 at Viking Blvd_2018

Ref. Pt: 029+00.797

Data Prepared By: ACS

TURNING MOVEMENT COUNT

File Name : TH-47 at Viking Blvd_2018

Site Code :

Start Date : 5/15/2018

Page No : 1

Groups Printed- Cars - Trucks

Start Time	TH-47 Southbound				Viking Blvd Westbound				TH-47 Northbound				Viking Blvd Eastbound				Int. Total
	Left	Thru	Right	Peds	Left	Thru	Right	Peds	Left	Thru	Right	Peds	Left	Thru	Right	Peds	
06:00	4	42	11	0	18	37	1	0	0	6	6	0	2	27	1	0	155
06:15	6	40	17	0	17	54	2	0	2	8	3	0	0	29	0	0	178
06:30	8	42	20	0	19	51	1	0	1	13	14	0	3	41	0	0	213
06:45	8	36	9	0	27	48	2	0	0	16	10	0	4	43	0	0	203
Total	26	160	57	0	81	190	6	0	3	43	33	0	9	140	1	0	749
07:00	10	38	19	0	20	51	2	0	0	13	8	0	4	47	0	0	212
07:15	10	41	16	0	20	50	5	0	1	6	4	0	8	36	1	0	198
07:30	19	31	9	0	21	54	3	0	1	19	17	0	9	64	0	0	247
07:45	4	52	8	0	24	58	2	0	1	19	15	0	3	66	0	0	252
Total	43	162	52	0	85	213	12	0	3	57	44	0	24	213	1	0	909
08:00	7	51	13	0	21	35	5	0	1	20	8	0	4	48	0	0	213
08:15	9	33	13	0	11	36	4	0	1	14	5	0	2	39	0	0	167
08:30	5	32	7	0	11	32	5	0	0	16	11	0	7	40	1	0	167
08:45	8	25	10	0	11	40	2	0	1	12	12	0	5	24	0	0	150
Total	29	141	43	0	54	143	16	0	3	62	36	0	18	151	1	0	697
09:00	6	40	7	0	11	38	2	0	1	17	6	0	3	26	0	0	157
09:15	7	30	9	0	10	26	1	0	2	9	10	0	4	31	2	0	141
09:30	4	28	8	0	8	31	3	0	0	21	3	0	4	24	0	0	134
09:45	4	31	5	0	6	25	3	0	0	15	6	0	3	29	2	0	129
Total	21	129	29	0	35	120	9	0	3	62	25	0	14	110	4	0	561
10:00	4	16	5	0	13	36	1	0	1	19	8	0	3	26	2	0	134
10:15	0	18	4	0	11	38	6	0	0	12	3	0	5	26	1	0	124
10:30	6	21	5	0	7	25	7	0	0	16	3	0	5	27	2	0	124
10:45	4	15	5	0	7	23	3	0	2	12	8	0	2	21	1	0	103
Total	14	70	19	0	38	122	17	0	3	59	22	0	15	100	6	0	485
11:00	2	11	3	0	8	32	5	0	0	17	4	0	2	21	1	0	106
11:15	3	17	7	0	1	17	7	0	2	23	4	0	5	23	0	0	109
11:30	5	23	8	0	6	30	3	0	0	16	13	0	4	26	0	0	134
11:45	2	23	7	0	10	32	6	0	0	14	8	0	5	29	3	0	139
Total	12	74	25	0	25	111	21	0	2	70	29	0	16	99	4	0	488
12:00	2	18	8	0	2	16	5	0	0	14	11	0	9	17	1	0	103
12:15	3	9	4	0	7	27	2	0	1	18	9	0	5	20	2	0	107
12:30	3	18	3	0	15	26	4	0	0	19	10	0	2	32	1	0	133
12:45	5	26	4	0	9	23	6	0	2	14	8	0	7	33	1	0	138
Total	13	71	19	0	33	92	17	0	3	65	38	0	23	102	5	0	481
13:00	4	22	4	0	11	24	6	0	4	22	9	0	8	24	1	0	139
13:15	1	17	8	0	6	20	5	0	2	20	7	0	6	25	2	0	119
13:30	3	18	11	0	1	27	4	0	1	11	9	0	4	27	0	0	116
13:45	1	18	8	0	6	26	4	0	1	15	6	0	8	23	1	0	117
Total	9	75	31	0	24	97	19	0	8	68	31	0	26	99	4	0	491
14:00	4	19	7	0	7	28	5	0	1	15	12	0	7	18	1	0	124
14:15	5	20	4	0	12	32	1	0	2	26	8	0	13	29	3	0	155
14:30	3	26	9	0	4	40	3	0	1	42	15	0	12	39	1	0	195

Associated Consulting Services (ACS)

Saint Paul, MN 55127

-- TRAFFIC DATA --

Location: TH-47 at Viking Blvd_2018

Ref. Pt: 029+00.797

Data Prepared By: ACS

TURNING MOVEMENT COUNT

File Name : TH-47 at Viking Blvd_2018

Site Code :

Start Date : 5/15/2018

Page No : 2

Groups Printed- Cars - Trucks

Start Time	TH-47 Southbound				Viking Blvd Westbound				TH-47 Northbound				Viking Blvd Eastbound				Int. Total
	Left	Thru	Right	Peds	Left	Thru	Right	Peds	Left	Thru	Right	Peds	Left	Thru	Right	Peds	
14:45	5	20	6	1	11	41	4	0	2	23	14	0	11	38	2	0	178
Total	17	85	26	1	34	141	13	0	6	106	49	0	43	124	7	0	652
15:00	5	23	10	0	17	34	8	0	3	39	12	0	12	50	1	0	214
15:15	8	23	8	0	11	34	13	0	3	32	16	0	12	51	2	0	213
15:30	4	19	9	0	14	40	6	0	1	48	18	0	13	62	1	0	235
15:45	5	26	12	0	14	59	5	0	1	45	17	1	9	50	1	0	245
Total	22	91	39	0	56	167	32	0	8	164	63	1	46	213	5	0	907
16:00	5	18	7	0	20	51	10	0	3	78	25	0	10	65	5	0	297
16:15	10	24	8	0	16	79	9	0	4	37	16	0	9	89	0	0	301
16:30	11	24	4	0	14	51	10	0	3	59	29	0	21	68	3	0	297
16:45	10	29	3	0	19	71	15	0	3	45	21	1	23	71	2	0	313
Total	36	95	22	0	69	252	44	0	13	219	91	1	63	293	10	0	1208
17:00	4	24	11	0	13	87	13	2	2	59	41	0	24	66	1	0	347
17:15	6	22	7	0	16	60	12	0	2	44	31	0	12	84	1	0	297
17:30	12	22	10	0	17	75	13	0	3	60	38	0	18	73	1	0	342
17:45	8	22	9	0	12	63	11	0	3	41	20	0	13	54	1	0	257
Total	30	90	37	0	58	285	49	2	10	204	130	0	67	277	4	0	1243
Grand Total	272	1243	399	1	592	1933	255	2	65	1179	591	2	364	1921	52	0	8871
Apprch %	14.2	64.9	20.8	0.1	21.3	69.5	9.2	0.1	3.5	64.2	32.2	0.1	15.6	82.2	2.2	0	
Total %	3.1	14	4.5	0	6.7	21.8	2.9	0	0.7	13.3	6.7	0	4.1	21.7	0.6	0	
Cars	256	1185	376	1	569	1743	241	2	59	1136	564	2	350	1712	46	0	8242
% Cars	94.1	95.3	94.2	100	96.1	90.2	94.5	100	90.8	96.4	95.4	100	96.2	89.1	88.5	0	92.9
Trucks	16	58	23	0	23	190	14	0	6	43	27	0	14	209	6	0	629
% Trucks	5.9	4.7	5.8	0	3.9	9.8	5.5	0	9.2	3.6	4.6	0	3.8	10.9	11.5	0	7.1

Associated Consulting Services (ACS)

Saint Paul, MN 55127

-- TRAFFIC DATA --

Location: TH-47 at Viking Blvd_2018

Ref. Pt: 029+00.797

Data Prepared By: ACS

TURNING MOVEMENT COUNT

File Name : TH-47 at Viking Blvd_2018

Site Code :

Start Date : 5/15/2018

Page No : 3

Start Time	TH-47 Southbound					Viking Blvd Westbound					TH-47 Northbound					Viking Blvd Eastbound					Int. Total
	Left	Thru	Right	Peds	App. Total	Left	Thru	Right	Peds	App. Total	Left	Thru	Right	Peds	App. Total	Left	Thru	Right	Peds	App. Total	
Peak Hour Analysis From 06:00 to 11:45 - Peak 1 of 1																					
Peak Hour for Entire Intersection Begins at 07:15																					
07:15	10	41	16	0	67	20	50	5	0	75	1	6	4	0	11	8	36	1	0	45	198
07:30	19	31	9	0	59	21	54	3	0	78	1	19	17	0	37	9	64	0	0	73	247
07:45	4	52	8	0	64	24	58	2	0	84	1	19	15	0	35	3	66	0	0	69	252
08:00	7	51	13	0	71	21	35	5	0	61	1	20	8	0	29	4	48	0	0	52	213
Total Volume	40	175	46	0	261	86	197	15	0	298	4	64	44	0	112	24	214	1	0	239	910
% App. Total	15.3	67	17.6	0		28.9	66.1	5	0		3.6	57.1	39.3	0		10	89.5	0.4	0		
PHF	.526	.841	.719	.000	.919	.896	.849	.750	.000	.887	1.0	.800	.647	.000	.757	.667	.811	.250	.000	.818	.903

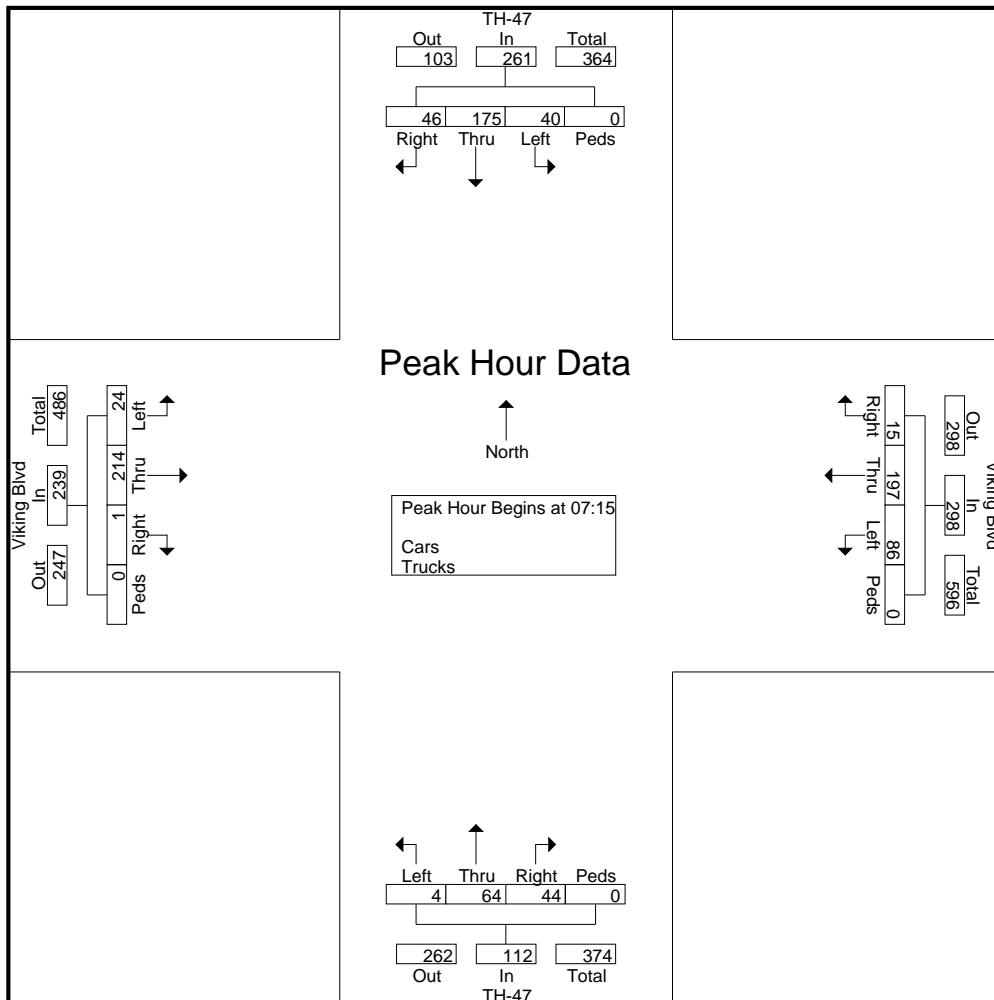

Associated Consulting Services (ACS)

Saint Paul, MN 55127

-- TRAFFIC DATA --

Location: TH-47 at Viking Blvd_2018

Ref. Pt: 029+00.797

Data Prepared By: ACS

TURNING MOVEMENT COUNT

File Name : TH-47 at Viking Blvd_2018

Site Code :

Start Date : 5/15/2018

Page No : 4

Start Time	TH-47 Southbound					Viking Blvd Westbound					TH-47 Northbound					Viking Blvd Eastbound					Int. Total
	Left	Thru	Right	Peds	App. Total	Left	Thru	Right	Peds	App. Total	Left	Thru	Right	Peds	App. Total	Left	Thru	Right	Peds	App. Total	
Peak Hour Analysis From 12:00 to 17:45 - Peak 1 of 1																					
Peak Hour for Entire Intersection Begins at 16:45																					
16:45	10	29	3	0	42	19	71	15	0	105	3	45	21	1	70	23	71	2	0	96	313
17:00	4	24	11	0	39	13	87	13	2	115	2	59	41	0	102	24	66	1	0	91	347
17:15	6	22	7	0	35	16	60	12	0	88	2	44	31	0	77	12	84	1	0	97	297
17:30	12	22	10	0	44	17	75	13	0	105	3	60	38	0	101	18	73	1	0	92	342
Total Volume	32	97	31	0	160	65	293	53	2	413	10	208	131	1	350	77	294	5	0	376	1299
% App. Total	20	60.6	19.4	0		15.7	70.9	12.8	0.5		2.9	59.4	37.4	0.3		20.5	78.2	1.3	0		
PHF	.667	.836	.705	.000	.909	.855	.842	.883	.250	.898	.833	.867	.799	.250	.858	.802	.875	.625	.000	.969	.936

