



MINNESOTA DEPT OF TRANSPORTATION

TRAFFIC DATA COLLECTION - METRO

MN-51 / SNELLING AVE AT MIDWAY PKWY Name : TH-51 SNELLING AVE AT MIDWAY PKWY 2007
REF.PT.: 005.614 **Site Code :** 00198731
DATA COLLECTED BY TDI **Start Date :** 5/22/2007
TURN MOVEMENT COUNT **Page No :** 1

Groups Printed- Unshifted

Start Time	MN-51 / SNELLING AVE. Southbound				MIDWAY PARKWAY Westbound				MN-51 / SNELLING AVE. Northbound				DAN PATCH AVE. Eastbound				Int. Total
	Left	Thru	Right	Peds	Left	Thru	Right	Peds	Left	Thru	Right	Peds	Left	Thru	Right	Peds	
06:00	6	129	1	5	0	0	4	1	1	70	0	0	0	0	0	0	217
06:15	5	186	4	2	1	0	5	6	6	84	2	5	0	0	7	0	313
06:30	2	248	7	11	3	1	4	0	8	134	0	2	0	1	0	0	421
06:45	4	311	11	1	4	2	3	0	15	144	4	1	1	0	0	0	501
Total	17	874	23	19	8	3	16	7	30	432	6	8	1	1	7	0	1452
07:00	7	292	8	4	8	1	6	1	11	173	3	0	0	0	2	0	516
07:15	5	372	4	3	10	5	5	3	13	209	3	0	1	0	3	0	636
07:30	8	349	2	2	11	3	7	0	21	278	4	0	2	0	1	0	688
07:45	7	420	11	1	18	3	5	0	14	265	6	0	0	2	3	1	756
Total	27	1433	25	10	47	12	23	4	59	925	16	0	3	2	9	1	2596
08:00	7	358	3	1	9	3	7	0	25	227	7	0	2	0	1	0	650
08:15	7	363	10	5	9	8	7	0	32	228	5	0	2	1	1	1	679
08:30	3	335	7	3	8	3	6	1	22	246	2	1	0	0	3	0	640
08:45	12	333	2	4	8	2	6	1	20	224	6	0	0	1	7	0	626
Total	29	1389	22	13	34	16	26	2	99	925	20	1	4	2	12	1	2595
*** BREAK ***																	
11:00	7	205	6	1	11	0	4	1	8	261	4	0	2	3	7	0	520
11:15	14	246	1	2	9	2	10	0	2	269	7	0	2	3	5	0	572
11:30	7	215	2	0	12	1	7	0	2	312	8	0	1	2	9	0	578
11:45	12	300	1	0	7	3	17	0	6	318	4	0	3	3	9	0	683
Total	40	966	10	3	39	6	38	1	18	1160	23	0	8	11	30	0	2353
12:00	5	254	4	1	12	7	9	0	7	313	12	1	3	4	4	0	636
12:15	7	277	2	0	7	2	13	0	3	331	5	0	2	2	4	0	655
12:30	11	293	7	0	17	2	8	0	5	291	10	0	2	2	2	1	651
12:45	11	310	5	2	5	2	13	1	6	286	8	0	4	0	2	0	655
Total	34	1134	18	3	41	13	43	1	21	1221	35	1	11	8	12	1	2597
*** BREAK ***																	
15:00	8	255	1	0	7	1	22	0	7	344	12	1	6	0	10	0	674
15:15	8	282	3	0	7	1	16	2	9	376	9	3	12	1	28	0	757
15:30	9	300	2	2	13	2	12	0	6	459	7	0	11	3	17	0	843
15:45	5	269	1	2	8	1	7	0	6	472	12	4	3	1	12	0	803
Total	30	1106	7	4	35	5	57	2	28	1651	40	8	32	5	67	0	3077
16:00	8	280	1	0	4	0	11	3	5	453	6	0	3	2	7	0	783
16:15	4	290	0	4	13	1	10	0	5	475	9	1	7	4	16	0	839
16:30	5	304	2	0	11	0	8	1	5	555	8	1	8	16	22	1	947
16:45	9	309	0	2	14	3	5	4	4	483	10	4	4	6	4	0	861
Total	26	1183	3	6	42	4	34	8	19	1966	33	6	22	28	49	1	3430
17:00	7	327	2	3	6	1	13	3	4	537	10	1	0	5	12	0	931
17:15	4	341	0	2	7	0	8	3	1	430	12	1	4	5	5	0	823
17:30	12	358	0	0	5	2	16	2	0	414	13	1	5	1	4	0	833
17:45	6	269	1	1	7	1	3	0	0	378	7	1	3	1	6	0	684
Total	29	1295	3	6	25	4	40	8	5	1759	42	4	12	12	27	0	3271



MINNESOTA DEPT OF TRANSPORTATION
 TRAFFIC DATA COLLECTION - METRO

MN-51 / SNELLING AVE AT MIDWAY PKWY Name : TH-51 SNELLING AVE AT MIDWAY PKWY 2007
 REF.PT.: 005.614 Site Code : 00198731
 DATA COLLECTED BY TDI Start Date : 5/22/2007
 TURN MOVEMENT COUNT Page No : 2

Groups Printed- Unshifted

	MN-51 / SNELLING AVE. Southbound				MIDWAY PARKWAY Westbound				MN-51 / SNELLING AVE. Northbound				DAN PATCH AVE. Eastbound				Int. Total
	Left	Thru	Right	Peds	Left	Thru	Right	Peds	Left	Thru	Right	Peds	Left	Thru	Right	Peds	
Grand Total	232	9380	111	64	271	63	277	33	279	10039	215	28	93	69	213	4	21371
Apprch %	2.4	95.8	1.1	0.7	42.1	9.8	43	5.1	2.6	95.1	2	0.3	24.5	18.2	56.2	1.1	
Total %	1.1	43.9	0.5	0.3	1.3	0.3	1.3	0.2	1.3	47	1	0.1	0.4	0.3	1	0	



MINNESOTA DEPT OF TRANSPORTATION

TRAFFIC DATA COLLECTION - METRO

MN-51 / SNELLING AVE AT MIDWAY PKWY **Site Name : TH-51 SNELLING AVE AT MIDWAY PKWY 2007**
REF.PT.: 005.614 **Site Code : 00198731**
DATA COLLECTED BY TDI **Start Date : 5/22/2007**
TURN MOVEMENT COUNT **Page No : 3**

Start Time	MN-51 / SNELLING AVE. Southbound					MIDWAY PARKWAY Westbound					MN-51 / SNELLING AVE. Northbound					DAN PATCH AVE. Eastbound					Int. Total
	Left	Thru	Right	Peds	App. Total	Left	Thru	Right	Peds	App. Total	Left	Thru	Right	Peds	App. Total	Left	Thru	Right	Peds	App. Total	
Peak Hour Analysis From 06:00 to 08:45 - Peak 1 of 1																					
Peak Hour for Entire Intersection Begins at 07:30																					
07:30	8	349	2	2	361	11	3	7	0	21	21	278	4	0	303	2	0	1	0	3	688
07:45	7	420	11	1	439	18	3	5	0	26	14	265	6	0	285	0	2	3	1	6	756
08:00	7	358	3	1	369	9	3	7	0	19	25	227	7	0	259	2	0	1	0	3	650
08:15	7	363	10	5	385	9	8	7	0	24	32	228	5	0	265	2	1	1	1	5	679
Total Volume	29	1490	26	9	1554	47	17	26	0	90	92	998	22	0	1112	6	3	6	2	17	2773
% App. Total	1.9	95.9	1.7	0.6		52.2	18.9	28.9	0		8.3	89.7	2	0		35.3	17.6	35.3	11.8		
PHF	.906	.887	.591	.450	.885	.653	.531	.929	.000	.865	.719	.897	.786	.000	.917	.750	.375	.500	.500	.708	.917

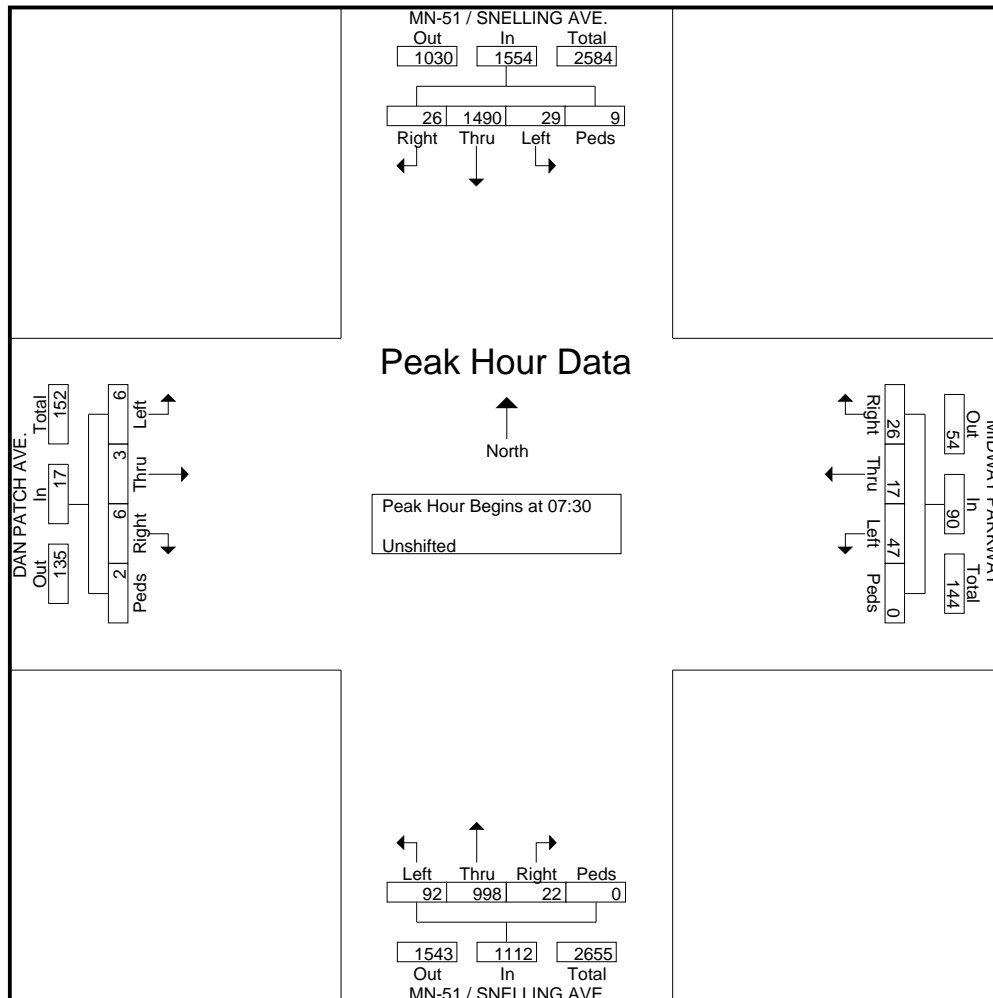



MINNESOTA DEPT OF TRANSPORTATION

TRAFFIC DATA COLLECTION - METRO

MN-51 / SNELLING AVE AT MIDWAY PKWY Name : TH-51 SNELLING AVE AT MIDWAY PKWY 2007
REF.PT.: 005.614 **Site Code :** 00198731
DATA COLLECTED BY TDI **Start Date :** 5/22/2007
TURN MOVEMENT COUNT **Page No :** 4

Start Time	MN-51 / SNELLING AVE. Southbound					MIDWAY PARKWAY Westbound					MN-51 / SNELLING AVE. Northbound					DAN PATCH AVE. Eastbound					Int. Total
	Left	Thru	Right	Peds	App. Total	Left	Thru	Right	Peds	App. Total	Left	Thru	Right	Peds	App. Total	Left	Thru	Right	Peds	App. Total	
Peak Hour Analysis From 15:00 to 17:45 - Peak 1 of 1																					
Peak Hour for Entire Intersection Begins at 16:15																					
16:15	4	290	0	4	298	13	1	10	0	24	5	475	9	1	490	7	4	16	0	27	839
16:30	5	304	2	0	311	11	0	8	1	20	5	555	8	1	569	8	16	22	1	47	947
16:45	9	309	0	2	320	14	3	5	4	26	4	483	10	4	501	4	6	4	0	14	861
17:00	7	327	2	3	339	6	1	13	3	23	4	537	10	1	552	0	5	12	0	17	931
Total Volume	25	1230	4	9	1268	44	5	36	8	93	18	2050	37	7	2112	19	31	54	1	105	3578
% App. Total	2	97	0.3	0.7		47.3	5.4	38.7	8.6		0.9	97.1	1.8	0.3		18.1	29.5	51.4	1		
PHF	.694	.940	.500	.563	.935	.786	.417	.692	.500	.894	.900	.923	.925	.438	.928	.594	.484	.614	.250	.559	.945

