



MINNESOTA DEPT OF TRANSPORTATION

TRAFFIC DATA COLLECTION - METRO

TH-51 / Snelling Ave. NB at Co.Rd.E

File Name : TH-51 at Co Rd E east ramps 2011

Ref.Pt.: 010.508

Site Code : 00000000

JAMAR # T-2638 CAH

Start Date : 8/24/2011

TURN MOVEMENT COUNT

Page No : 1

Groups Printed- Cars & Trucks

Start Time	Connelly St Southbound				Co.Rd. E Westbound				Ramp from & loop to : TH-51 / Snelling Ave NB Northbound				Co.Rd. E Eastbound				Int. Total
	Left	Thru	Right	Peds	Left	Thru	Right	Peds	Left	Thru	Right	Peds	Left	Thru	Right	Peds	
06:00	1	0	0	0	4	27	0	1	3	0	6	1	0	25	4	0	72
06:15	1	1	0	0	4	24	1	0	3	1	6	0	0	30	8	0	79
06:30	0	0	1	0	9	31	1	2	5	0	12	0	3	33	9	3	109
06:45	0	0	0	0	11	54	0	1	8	2	13	0	4	58	11	1	163
Total	2	1	1	0	28	136	2	4	19	3	37	1	7	146	32	4	423
07:00	0	0	0	0	21	85	2	2	8	2	16	0	2	68	17	1	224
07:15	3	2	2	0	16	110	0	2	10	0	25	0	5	77	18	1	271
07:30	3	0	0	0	25	134	1	2	15	0	28	2	2	96	17	4	329
07:45	1	1	1	0	26	143	4	2	15	1	55	0	10	117	33	0	409
Total	7	3	3	0	88	472	7	8	48	3	124	2	19	358	85	6	1233
08:00	1	1	1	0	14	108	1	0	16	0	37	0	0	93	32	0	304
08:15	4	2	1	0	11	98	2	1	11	0	31	0	2	71	22	1	257
08:30	1	0	0	0	12	94	2	0	13	0	24	0	2	83	14	1	246
08:45	2	0	0	0	9	75	4	1	13	1	35	0	6	93	21	0	260
Total	8	3	2	0	46	375	9	2	53	1	127	0	10	340	89	2	1067
*** BREAK ***																	
15:00	5	1	2	0	30	81	4	2	21	1	53	0	2	86	23	1	312
15:15	5	3	6	1	29	98	4	1	24	3	62	0	3	93	28	1	361
15:30	4	5	3	0	39	122	6	0	12	0	61	0	1	147	24	0	424
15:45	3	2	0	0	29	126	1	1	19	2	63	0	6	130	41	1	424
Total	17	11	11	1	127	427	15	4	76	6	239	0	12	456	116	3	1521
16:00	2	4	3	0	49	126	4	2	17	4	66	0	9	122	45	0	453
16:15	3	1	1	0	73	131	5	3	26	1	63	2	2	150	48	3	512
16:30	2	6	1	0	67	143	4	1	30	3	43	1	7	156	75	1	540
16:45	4	4	8	0	53	153	6	2	29	0	41	1	10	178	64	2	555
Total	11	15	13	0	242	553	19	8	102	8	213	4	28	606	232	6	2060
17:00	5	2	5	0	65	166	4	2	30	2	69	0	3	178	62	2	595
17:15	7	5	7	0	51	169	4	1	32	3	61	0	2	178	55	1	576
17:30	2	2	1	0	40	140	2	2	30	2	54	0	2	176	70	4	527
17:45	5	0	2	0	41	119	9	3	34	4	52	0	3	170	47	1	490
Total	19	9	15	0	197	594	19	8	126	11	236	0	10	702	234	8	2188
Grand Total	64	42	45	1	728	2557	71	34	424	32	976	7	86	2608	788	29	8492
Apprch %	42.1	27.6	29.6	0.7	21.5	75.4	2.1	1	29.5	2.2	67.8	0.5	2.4	74.3	22.4	0.8	
Total %	0.8	0.5	0.5	0	8.6	30.1	0.8	0.4	5	0.4	11.5	0.1	1	30.7	9.3	0.3	



MINNESOTA DEPT OF TRANSPORTATION

TRAFFIC DATA COLLECTION - METRO

TH-51 / Snelling Ave. NB at Co.Rd.E

File Name : TH-51 at Co Rd E east ramps 2011

Ref.Pt.: 010.508

Site Code : 00000000

JAMAR # T-2638 CAH

Start Date : 8/24/2011

TURN MOVEMENT COUNT

Page No : 2

Start Time	Connelly St Southbound					Co.Rd. E Westbound					Ramp from & loop to : TH-51 / Snelling Ave NB Northbound					Co.Rd. E Eastbound					Int. Total
	Left	Thru	Right	Peds	App. Total	Left	Thru	Right	Peds	App. Total	Left	Thru	Right	Peds	App. Total	Left	Thru	Right	Peds	App. Total	
Peak Hour Analysis From 06:00 to 08:45 - Peak 1 of 1																					
Peak Hour for Entire Intersection Begins at 07:15																					
07:15	3	2	2	0	7	16	110	0	2	128	10	0	25	0	35	5	77	18	1	101	271
07:30	3	0	0	0	3	25	134	1	2	162	15	0	28	2	45	2	96	17	4	119	329
07:45	1	1	1	0	3	26	143	4	2	175	15	1	55	0	71	10	117	33	0	160	409
08:00	1	1	1	0	3	14	108	1	0	123	16	0	37	0	53	0	93	32	0	125	304
Total Volume	8	4	4	0	16	81	495	6	6	588	56	1	145	2	204	17	383	100	5	505	1313
% App. Total	50	25	25	0		13.8	84.2	1	1		27.5	0.5	71.1	1		3.4	75.8	19.8	1		
PHF	.667	.500	.500	.000	.571	.779	.865	.375	.750	.840	.875	.250	.659	.250	.718	.425	.818	.758	.313	.789	.803

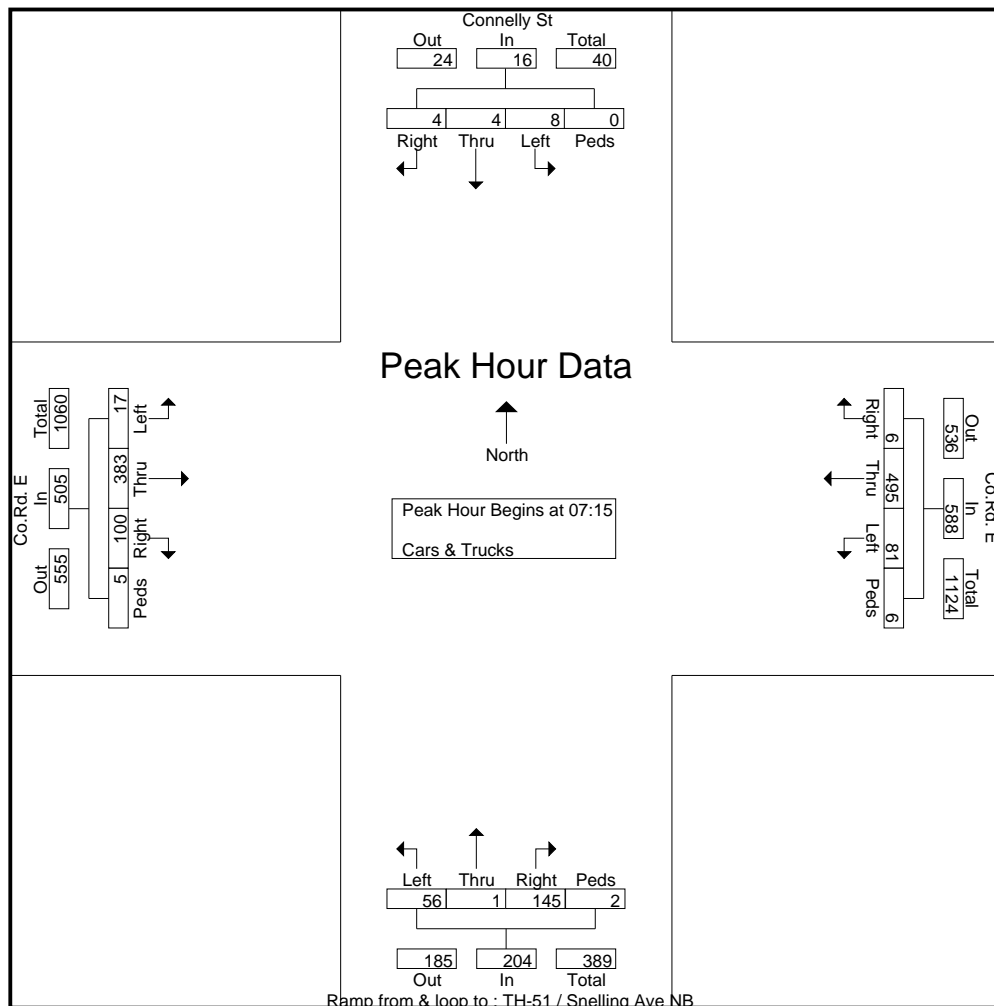



MINNESOTA DEPT OF TRANSPORTATION

TRAFFIC DATA COLLECTION - METRO

TH-51 / Snelling Ave. NB at Co.Rd.E

File Name : TH-51 at Co Rd E east ramps 2011

Ref.Pt.: 010.508

Site Code : 00000000

JAMAR # T-2638 CAH

Start Date : 8/24/2011

TURN MOVEMENT COUNT

Page No : 3

Start Time	Connelly St Southbound					Co.Rd. E Westbound					Ramp from & loop to : TH-51 / Snelling Ave NB Northbound					Co.Rd. E Eastbound					Int. Total
	Left	Thru	Right	Peds	App. Total	Left	Thru	Right	Peds	App. Total	Left	Thru	Right	Peds	App. Total	Left	Thru	Right	Peds	App. Total	
Peak Hour Analysis From 15:00 to 17:45 - Peak 1 of 1																					
Peak Hour for Entire Intersection Begins at 16:30																					
16:30	2	6	1	0	9	67	143	4	1	215	30	3	43	1	77	7	156	75	1	239	540
16:45	4	4	8	0	16	53	153	6	2	214	29	0	41	1	71	10	178	64	2	254	555
17:00	5	2	5	0	12	65	166	4	2	237	30	2	69	0	101	3	178	62	2	245	595
17:15	7	5	7	0	19	51	169	4	1	225	32	3	61	0	96	2	178	55	1	236	576
Total Volume	18	17	21	0	56	236	631	18	6	891	121	8	214	2	345	22	690	256	6	974	2266
% App. Total	32.1	30.4	37.5	0		26.5	70.8	2	0.7		35.1	2.3	62	0.6		2.3	70.8	26.3	0.6		
PHF	.643	.708	.656	.000	.737	.881	.933	.750	.750	.940	.945	.667	.775	.500	.854	.550	.969	.853	.750	.959	.952

