



MINNESOTA DEPT OF TRANSPORTATION

TRAFFIC DATA COLLECTION - METRO

Counted By: Robert & Dorothy
 Day of the Week: Wednesday
 Location: TH 55 & Douglas
 Project #: 5764

File Name : TH 55 @ DOUGLAS DR 2006
 Site Code : 08022312
 Start Date : 8/2/2006
 Page No : 1

Groups Printed- Unshifted

Start Time	Douglas Southbound					TH 55 Westbound					Douglas Northbound					TH 55 Eastbound					Int. Total
	Left	Thru	Right	Peds	App. Total	Left	Thru	Right	Peds	App. Total	Left	Thru	Right	Peds	App. Total	Left	Thru	Right	Peds	App. Total	
06:00	35	9	15	0	59	3	87	24	0	114	1	4	1	0	6	28	97	2	0	127	306
06:15	25	1	8	0	34	3	130	33	1	167	4	3	4	0	11	23	123	0	0	146	358
06:30	45	2	16	0	63	0	188	55	0	243	0	4	2	0	6	51	210	3	0	264	576
06:45	51	10	18	0	79	1	224	74	1	300	4	8	3	0	15	60	248	2	0	310	704
Total	156	22	57	0	235	7	629	186	2	824	9	19	10	0	38	162	678	7	0	847	1944
07:00	58	8	19	0	85	5	222	91	0	318	4	7	3	0	14	86	279	3	0	368	785
07:15	91	21	35	0	147	4	244	77	0	325	3	8	3	0	14	59	304	1	0	364	850
07:30	93	21	46	0	160	3	249	85	0	337	5	6	0	0	11	57	358	2	0	417	925
07:45	89	26	51	0	166	0	284	100	0	384	1	17	1	0	19	89	336	2	0	427	996
Total	331	76	151	0	558	12	999	353	0	1364	13	38	7	0	58	291	1277	8	0	1576	3556
08:00	93	24	46	0	163	3	249	93	0	345	5	7	5	0	17	75	376	1	0	452	977
08:15	64	14	26	0	104	1	262	78	0	341	4	9	3	0	16	75	375	4	0	454	915
08:30	71	11	30	0	112	2	218	102	0	322	3	7	7	0	17	73	309	3	0	385	836
08:45	46	9	31	0	86	2	202	98	1	303	2	9	4	0	15	67	341	2	0	410	814
Total	274	58	133	0	465	8	931	371	1	1311	14	32	19	0	65	290	1401	10	0	1701	3542
11:00	71	17	39	0	127	3	135	40	0	178	4	8	6	0	18	32	163	2	0	197	520
11:15	51	13	59	0	123	5	197	39	0	241	4	5	5	0	14	28	191	4	0	223	601
11:30	79	12	56	0	147	7	188	35	0	230	2	14	4	0	20	42	156	2	0	200	597
11:45	44	14	43	0	101	3	211	46	1	261	10	10	0	0	20	28	188	2	0	218	600
Total	245	56	197	0	498	18	731	160	1	910	20	37	15	0	72	130	698	10	0	838	2318
12:00	66	4	53	0	123	2	191	48	0	241	9	13	7	0	29	53	190	6	0	249	642
12:15	69	14	37	0	120	5	200	49	0	254	5	16	4	0	25	55	177	2	0	234	633
12:30	63	14	34	0	111	74	127	44	0	245	2	18	6	0	26	49	192	5	0	246	628
12:45	77	9	52	0	138	5	201	52	4	262	6	13	3	0	22	42	241	3	0	286	708
Total	275	41	176	0	492	86	719	193	4	1002	22	60	20	0	102	199	800	16	0	1015	2611
15:00	98	9	84	0	191	4	185	40	0	229	0	9	0	0	9	43	250	2	0	295	724
15:15	82	5	50	0	137	4	200	42	0	246	7	11	3	0	21	43	272	3	0	318	722
15:30	94	11	63	0	168	4	264	43	1	312	7	11	0	0	18	37	291	3	0	331	829
15:45	57	8	68	0	133	3	269	49	5	326	3	16	3	0	22	48	315	1	0	364	845
Total	331	33	265	0	629	15	918	174	6	1113	17	47	6	0	70	171	1128	9	0	1308	3120
16:00	112	11	91	0	214	1	262	54	1	318	11	16	2	0	29	36	345	1	0	382	943
16:15	85	19	57	0	161	1	275	58	0	334	12	18	2	0	32	65	374	11	0	450	977
16:30	113	31	103	0	247	5	244	52	0	301	5	28	3	0	36	48	324	5	0	377	961
16:45	90	15	78	0	183	2	287	49	0	338	6	21	1	0	28	68	385	11	0	464	1013
Total	400	76	329	0	805	9	1068	213	1	1291	34	83	8	0	125	217	1428	28	0	1673	3894
17:00	104	31	103	2	240	6	347	69	0	422	6	21	4	0	31	49	349	10	0	408	1101
17:15	78	22	77	0	177	5	356	64	0	425	3	22	1	0	26	60	361	7	0	428	1056
17:30	84	20	66	0	170	5	266	69	0	340	2	23	4	0	29	78	348	9	0	435	974
17:45	63	19	51	0	133	6	223	74	0	303	10	23	1	0	34	63	351	14	1	429	899
Total	329	92	297	2	720	22	1192	276	0	1490	21	89	10	0	120	250	1409	40	1	1700	4030
Grand Total	2341	454	1605	2	4402	177	7187	1926	15	9305	150	405	95	0	650	1710	8819	128	1	10658	25015
Apprch %	53.2	10.3	36.5	0		1.9	77.2	20.7	0.2		23.1	62.3	14.6	0		16	82.7	1.2	0		
Total %	9.4	1.8	6.4	0	17.6	0.7	28.7	7.7	0.1	37.2	0.6	1.6	0.4	0	2.6	6.8	35.3	0.5	0	42.6	



MINNESOTA DEPT OF TRANSPORTATION

TRAFFIC DATA COLLECTION - METRO

File Name : TH 55 @ DOUGLAS DR 2006
Site Code : 08022312
Start Date : 8/2/2006
Page No : 2

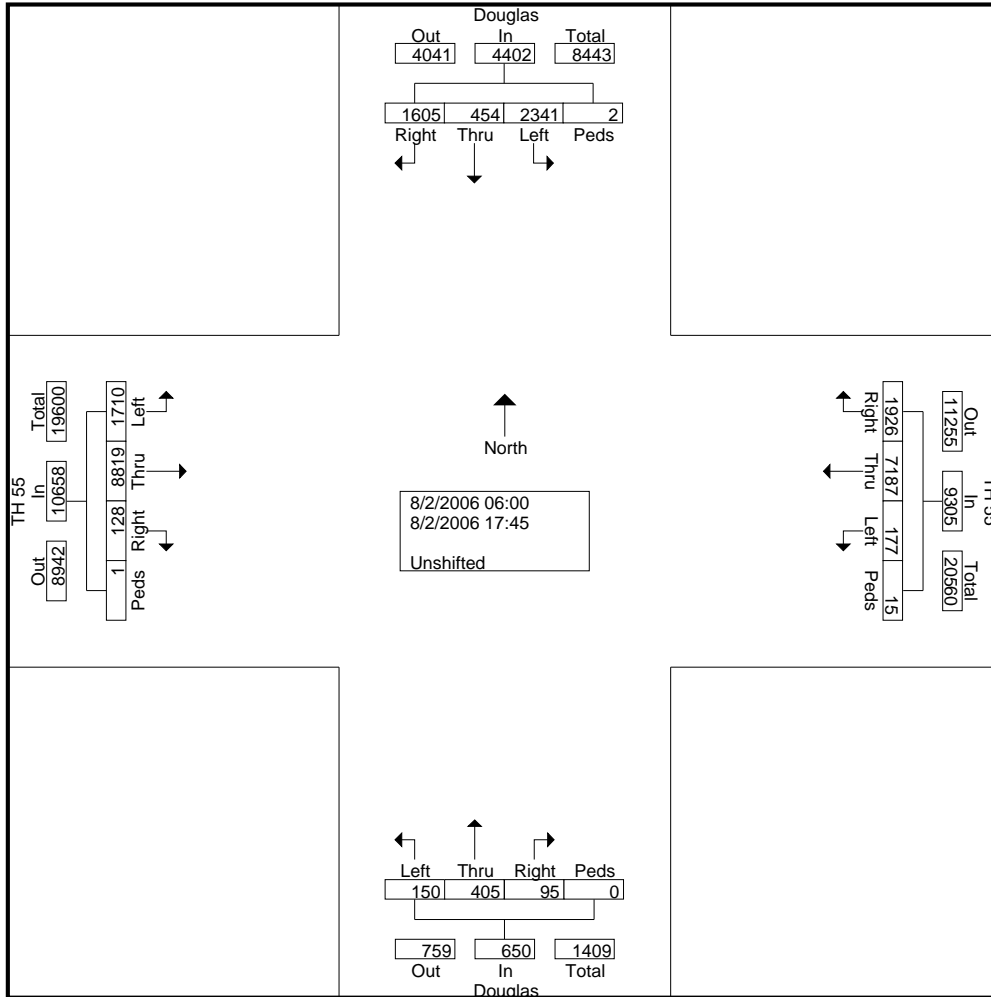



MINNESOTA DEPT OF TRANSPORTATION

TRAFFIC DATA COLLECTION - METRO

File Name : TH 55 @ DOUGLAS DR 2006
 Site Code : 08022312
 Start Date : 8/2/2006
 Page No : 3

Start Time	Douglas Southbound					TH 55 Westbound					Douglas Northbound					TH 55 Eastbound					Int. Total
	Left	Thru	Right	Peds	App. Total	Left	Thru	Right	Peds	App. Total	Left	Thru	Right	Peds	App. Total	Left	Thru	Right	Peds	App. Total	
07:30	93	21	46	0	160	3	249	85	0	337	5	6	0	0	11	57	358	2	0	417	925
07:45	89	26	51	0	166	0	284	100	0	384	1	17	1	0	19	89	336	2	0	427	996
08:00	93	24	46	0	163	3	249	93	0	345	5	7	5	0	17	75	376	1	0	452	977
08:15	64	14	26	0	104	1	262	78	0	341	4	9	3	0	16	75	375	4	0	454	915
Total Volume	339	85	169	0	593	7	1044	356	0	1407	15	39	9	0	63	296	1445	9	0	1750	3813
% App. Total	57.2	14.3	28.5	0		0.5	74.2	25.3	0		23.8	61.9	14.3	0		16.9	82.6	0.5	0		
PHF	.911	.817	.828	.000	.893	.583	.919	.890	.000	.916	.750	.574	.450	.000	.829	.831	.961	.563	.000	.964	.957

Peak Hour Analysis From 06:00 to 09:45 - Peak 1 of 1
 Peak Hour for Entire Intersection Begins at 07:30

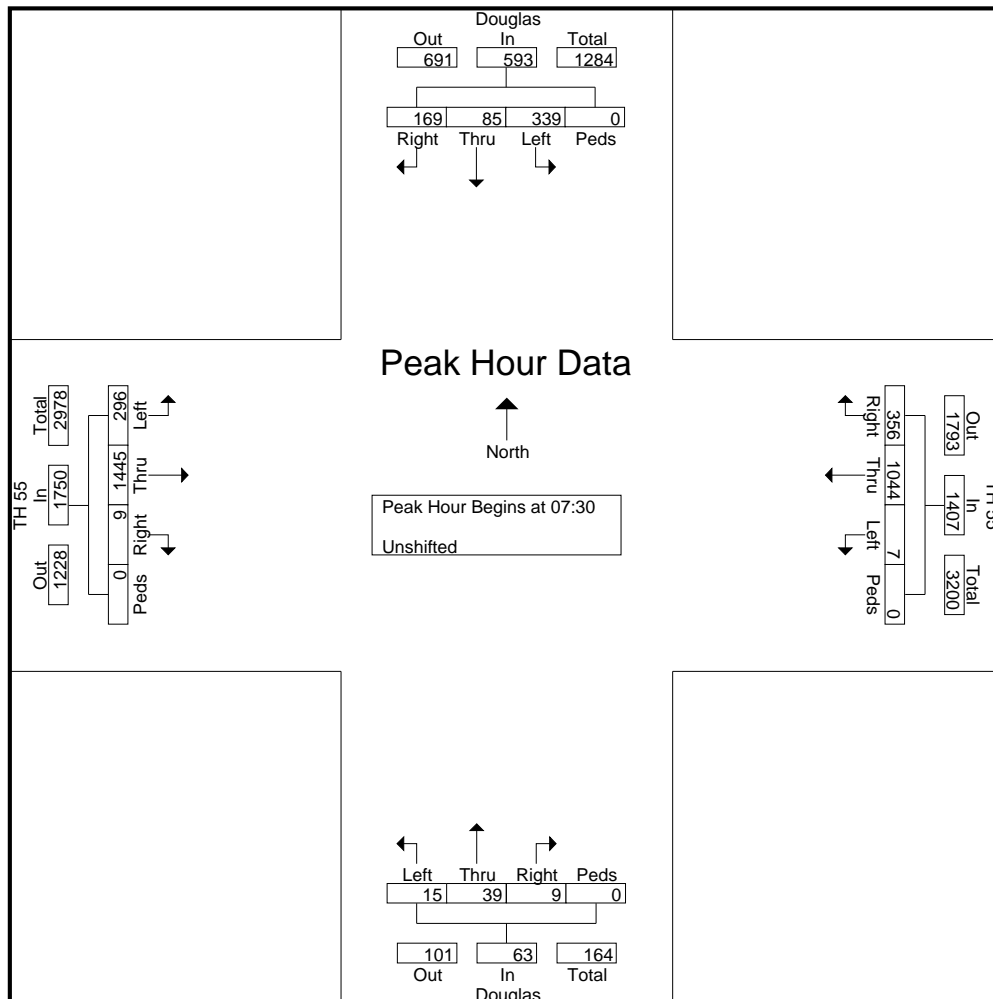



MINNESOTA DEPT OF TRANSPORTATION

TRAFFIC DATA COLLECTION - METRO

File Name : TH 55 @ DOUGLAS DR 2006
 Site Code : 08022312
 Start Date : 8/2/2006
 Page No : 4

Start Time	Douglas Southbound					TH 55 Westbound					Douglas Northbound					TH 55 Eastbound					Int. Total
	Left	Thru	Right	Peds	App. Total	Left	Thru	Right	Peds	App. Total	Left	Thru	Right	Peds	App. Total	Left	Thru	Right	Peds	App. Total	
12:00	66	4	53	0	123	2	191	48	0	241	9	13	7	0	29	53	190	6	0	249	642
12:15	69	14	37	0	120	5	200	49	0	254	5	16	4	0	25	55	177	2	0	234	633
12:30	63	14	34	0	111	74	127	44	0	245	2	18	6	0	26	49	192	5	0	246	628
12:45	77	9	52	0	138	5	201	52	4	262	6	13	3	0	22	42	241	3	0	286	708
Total Volume	275	41	176	0	492	86	719	193	4	1002	22	60	20	0	102	199	800	16	0	1015	2611
% App. Total	55.9	8.3	35.8	0		8.6	71.8	19.3	0.4		21.6	58.8	19.6	0		19.6	78.8	1.6	0		
PHF	.893	.732	.830	.000	.891	.291	.894	.928	.250	.956	.611	.833	.714	.000	.879	.905	.830	.667	.000	.887	.922

Peak Hour Analysis From 10:00 to 13:45 - Peak 1 of 1
 Peak Hour for Entire Intersection Begins at 12:00

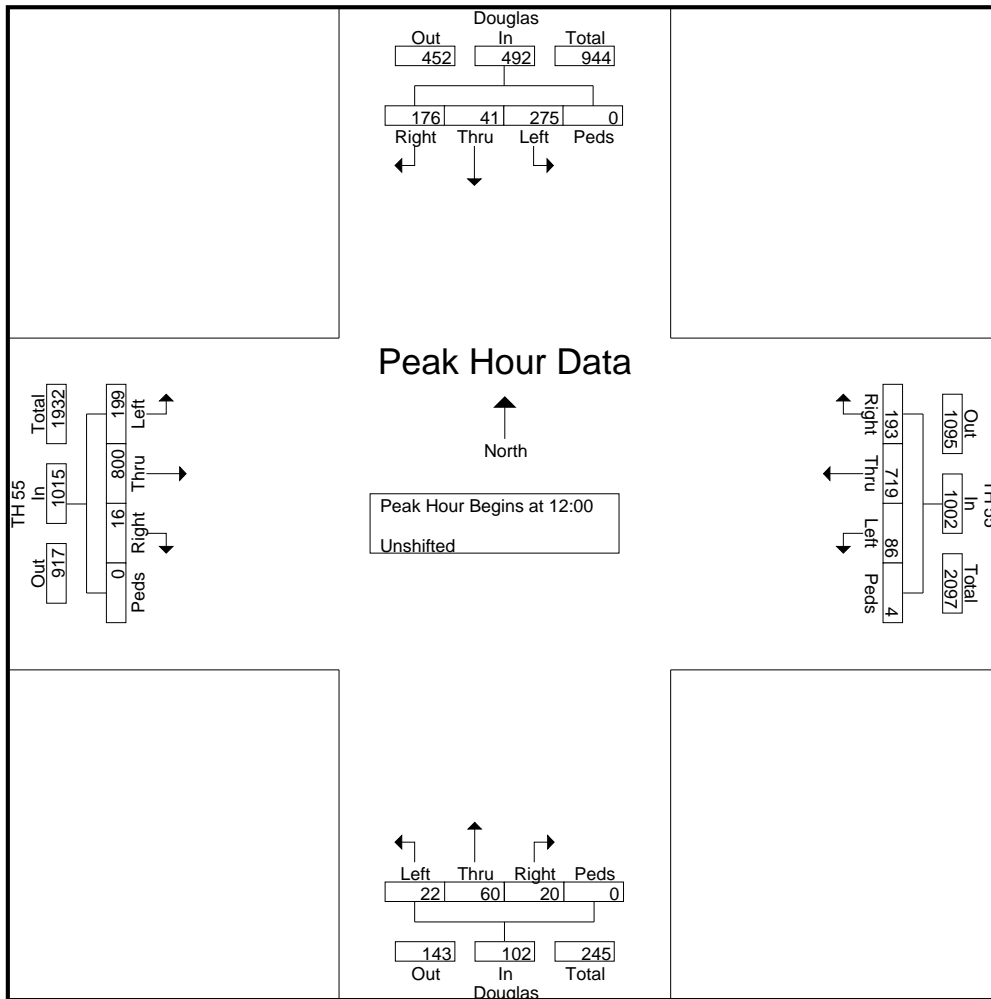



MINNESOTA DEPT OF TRANSPORTATION

TRAFFIC DATA COLLECTION - METRO

File Name : TH 55 @ DOUGLAS DR 2006
 Site Code : 08022312
 Start Date : 8/2/2006
 Page No : 5

Start Time	Douglas Southbound					TH 55 Westbound					Douglas Northbound					TH 55 Eastbound					Int. Total
	Left	Thru	Right	Peds	App. Total	Left	Thru	Right	Peds	App. Total	Left	Thru	Right	Peds	App. Total	Left	Thru	Right	Peds	App. Total	
16:45	90	15	78	0	183	2	287	49	0	338	6	21	1	0	28	68	385	11	0	464	1013
17:00	104	31	103	2	240	6	347	69	0	422	6	21	4	0	31	49	349	10	0	408	1101
17:15	78	22	77	0	177	5	356	64	0	425	3	22	1	0	26	60	361	7	0	428	1056
17:30	84	20	66	0	170	5	266	69	0	340	2	23	4	0	29	78	348	9	0	435	974
Total Volume	356	88	324	2	770	18	1256	251	0	1525	17	87	10	0	114	255	1443	37	0	1735	4144
% App. Total	46.2	11.4	42.1	0.3		1.2	82.4	16.5	0		14.9	76.3	8.8	0		14.7	83.2	2.1	0		
PHF	.856	.710	.786	.250	.802	.750	.882	.909	.000	.897	.708	.946	.625	.000	.919	.817	.937	.841	.000	.935	.941

Peak Hour Analysis From 14:00 to 17:45 - Peak 1 of 1
 Peak Hour for Entire Intersection Begins at 16:45

