

Associated Consulting Services (ACS)

Saint Paul, MN 55127

-- TRAFFIC DATA --

TH-95 at Chestnut St._2019 (Sat)

Ref Pt: 104+00.141

Data Prepared By: ACS

TURNING MOVEMENT COUNT

File Name : TH-95 at Chestnut St._2019 (Sat)

Site Code :

Start Date : 6/15/2019

Page No : 1

Groups Printed- Cars - Trucks

Start Time	TH-95 Southbound				Chestnut St Westbound				TH-95 Northbound				Chestnut St Eastbound				Int. Total	
	Left	Thru	Right	Peds	Left	Thru	Right	Peds	Left	Thru	Right	Peds	Left	Thru	Right	Peds		
06:00	0	13	1	0	0	0	0	0	0	5	0	0	0	0	0	0	0	19
06:15	0	10	2	0	0	0	0	2	0	10	0	2	0	0	2	0	0	28
06:30	0	14	0	0	0	0	0	0	1	13	0	0	0	0	3	2	0	33
06:45	1	24	1	0	1	0	2	0	0	16	1	0	1	2	0	0	0	49
Total	1	61	4	0	1	0	2	2	1	44	1	2	1	2	5	2	0	129
07:00	1	24	2	0	0	1	3	0	0	27	0	0	1	1	1	2	0	63
07:15	0	38	4	2	0	0	0	2	0	24	0	0	1	0	1	4	0	76
07:30	1	37	4	1	0	0	2	1	0	18	0	1	0	1	3	1	0	70
07:45	1	31	0	4	0	0	1	2	0	31	0	0	3	1	2	6	0	82
Total	3	130	10	7	0	1	6	5	0	100	0	1	5	3	7	13	0	291
08:00	4	31	1	5	0	1	2	5	0	23	2	1	3	2	3	3	0	86
08:15	3	30	1	1	1	0	0	3	0	40	2	0	3	0	4	3	0	91
08:30	1	51	4	3	1	0	1	5	0	45	1	0	1	1	3	4	0	121
08:45	5	56	4	0	1	1	1	4	0	56	5	1	3	1	9	0	0	147
Total	13	168	10	9	3	2	4	17	0	164	10	2	10	4	19	10	0	445
09:00	2	55	5	0	2	2	2	0	0	51	1	0	3	3	6	7	0	139
09:15	2	57	6	6	0	1	1	6	1	58	2	3	5	2	9	4	0	163
09:30	1	82	9	3	1	1	1	6	0	68	1	10	8	3	9	17	0	220
09:45	6	66	11	5	1	2	1	21	3	75	3	2	8	2	9	35	0	250
Total	11	260	31	14	4	6	5	33	4	252	7	15	24	10	33	63	0	772
10:00	2	69	10	0	3	3	1	5	1	76	4	8	4	4	7	28	0	225
10:15	2	53	6	8	0	2	1	28	2	85	6	7	6	3	17	28	0	254
10:30	2	78	5	9	2	0	3	33	0	79	3	9	6	4	7	27	0	267
10:45	5	85	5	11	4	2	6	67	1	76	3	15	6	2	14	38	0	340
Total	11	285	26	28	9	7	11	133	4	316	16	39	22	13	45	121	0	1086
11:00	3	81	8	5	0	0	1	42	0	78	8	17	10	1	8	49	0	311
11:15	3	68	3	21	5	3	1	45	0	89	9	16	7	4	7	67	0	348
11:30	2	81	9	29	2	0	4	37	0	65	11	17	7	1	14	79	0	358
11:45	2	80	4	12	2	4	2	70	2	104	6	27	6	7	9	56	0	393
Total	10	310	24	67	9	7	8	194	2	336	34	77	30	13	38	251	0	1410
12:00	4	87	5	21	8	2	0	68	1	89	9	27	6	4	13	63	0	407
12:15	3	75	6	36	3	5	0	101	1	91	3	47	5	1	11	81	0	469
12:30	7	71	9	24	7	4	3	90	2	104	2	43	6	2	7	62	0	443
12:45	4	96	2	36	3	1	1	92	2	104	6	43	7	7	12	129	0	545
Total	18	329	22	117	21	12	4	351	6	388	20	160	24	14	43	335	0	1864
13:00	2	69	7	25	3	3	4	103	0	87	4	46	4	5	6	95	0	463
13:15	4	94	5	32	1	4	8	114	3	88	4	51	7	4	17	96	0	532
13:30	5	87	3	24	4	2	0	81	2	91	4	50	4	2	10	117	0	486
13:45	3	78	6	21	7	4	2	120	1	107	5	62	11	6	16	69	0	518
Total	14	328	21	102	15	13	14	418	6	373	17	209	26	17	49	377	0	1999
14:00	4	71	12	22	4	1	4	112	1	107	7	54	4	3	11	141	0	558
14:15	3	85	10	63	2	4	4	97	1	88	7	28	6	4	11	117	0	530
14:30	0	92	5	11	8	0	2	139	0	117	10	78	10	4	6	146	0	628

Associated Consulting Services (ACS)

Saint Paul, MN 55127

-- TRAFFIC DATA --

TH-95 at Chestnut St._2019 (Sat)

Ref Pt: 104+00.141

Data Prepared By: ACS

TURNING MOVEMENT COUNT

File Name : TH-95 at Chestnut St._2019 (Sat)

Site Code :

Start Date : 6/15/2019

Page No : 2

Groups Printed- Cars - Trucks

Start Time	TH-95 Southbound				Chestnut St Westbound				TH-95 Northbound				Chestnut St Eastbound				Int. Total
	Left	Thru	Right	Peds	Left	Thru	Right	Peds	Left	Thru	Right	Peds	Left	Thru	Right	Peds	
14:45	3	87	3	28	2	1	8	115	2	112	7	51	13	0	9	118	559
Total	10	335	30	124	16	6	18	463	4	424	31	211	33	11	37	522	2275
15:00	3	80	5	31	0	5	4	92	0	95	3	51	6	2	9	55	441
15:15	6	94	6	27	9	2	2	113	1	89	5	40	5	3	10	103	515
15:30	4	98	2	44	1	4	2	162	2	88	5	57	11	3	10	89	582
15:45	2	89	6	36	6	2	1	105	1	95	10	54	8	4	14	111	544
Total	15	361	19	138	16	13	9	472	4	367	23	202	30	12	43	358	2082
16:00	7	106	3	21	7	7	1	100	0	105	8	72	8	4	17	94	560
16:15	1	85	5	30	6	4	6	105	0	111	8	52	9	4	12	107	545
16:30	2	97	5	29	2	2	3	118	0	92	7	33	6	3	11	97	507
16:45	3	90	4	37	8	0	2	133	0	84	11	47	7	3	8	69	506
Total	13	378	17	117	23	13	12	456	0	392	34	204	30	14	48	367	2118
17:00	3	100	7	23	2	3	4	78	1	66	8	33	7	2	6	98	441
17:15	2	89	5	45	4	5	5	108	1	93	9	34	6	2	11	77	496
17:30	6	87	5	19	5	0	6	70	2	95	10	41	6	0	11	103	466
17:45	0	77	3	17	1	4	6	76	2	73	9	35	7	2	8	97	417
Total	11	353	20	104	12	12	21	332	6	327	36	143	26	6	36	375	1820
Grand Total	130	3298	234	827	129	92	114	2876	37	3483	229	1265	261	119	403	2794	16291
Apprch %	2.9	73.5	5.2	18.4	4	2.9	3.6	89.6	0.7	69.5	4.6	25.2	7.3	3.3	11.3	78.1	
Total %	0.8	20.2	1.4	5.1	0.8	0.6	0.7	17.7	0.2	21.4	1.4	7.8	1.6	0.7	2.5	17.2	
Cars	129	3275	234	827	127	91	111	2876	37	3457	228	1265	258	118	401	2794	16228
% Cars	99.2	99.3	100	100	98.4	98.9	97.4	100	100	99.3	99.6	100	98.9	99.2	99.5	100	99.6
Trucks	1	23	0	0	2	1	3	0	0	26	1	0	3	1	2	0	63
% Trucks	0.8	0.7	0	0	1.6	1.1	2.6	0	0	0.7	0.4	0	1.1	0.8	0.5	0	0.4

Associated Consulting Services (ACS)

Saint Paul, MN 55127

-- TRAFFIC DATA --

TH-95 at Chestnut St._2019 (Sat)
 Ref Pt: 104+00.141
 Data Prepared By: ACS
 TURNING MOVEMENT COUNT

File Name : TH-95 at Chestnut St._2019 (Sat)
 Site Code :
 Start Date : 6/15/2019
 Page No : 3

Start Time	TH-95 Southbound					Chestnut St Westbound					TH-95 Northbound					Chestnut St Eastbound					Int. Total
	Left	Thru	Right	Peds	App. Total	Left	Thru	Right	Peds	App. Total	Left	Thru	Right	Peds	App. Total	Left	Thru	Right	Peds	App. Total	
Peak Hour Analysis From 06:00 to 11:45 - Peak 1 of 1																					
Peak Hour for Entire Intersection Begins at 11:00																					
11:00	3	81	8	5	97	0	0	1	42	43	0	78	8	17	103	10	1	8	49	68	311
11:15	3	68	3	21	95	5	3	1	45	54	0	89	9	16	114	7	4	7	67	85	348
11:30	2	81	9	29	121	2	0	4	37	43	0	65	11	17	93	7	1	14	79	101	358
11:45	2	80	4	12	98	2	4	2	70	78	2	104	6	27	139	6	7	9	56	78	393
Total Volume	10	310	24	67	411	9	7	8	194	218	2	336	34	77	449	30	13	38	251	332	1410
% App. Total	2.4	75.4	5.8	16.3		4.1	3.2	3.7	89		0.4	74.8	7.6	17.1		9	3.9	11.4	75.6		
PHF	.833	.957	.667	.578	.849	.450	.438	.500	.693	.699	.250	.808	.773	.713	.808	.750	.464	.679	.794	.822	.897

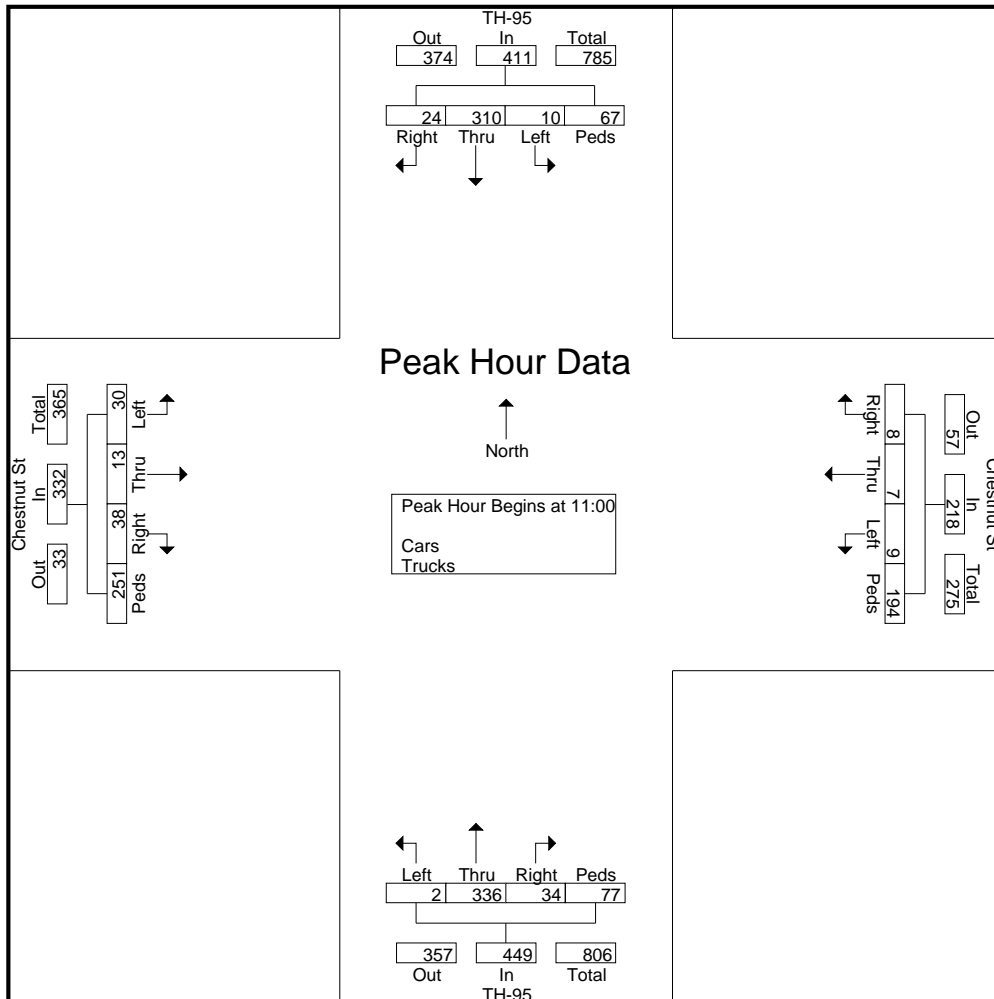

Associated Consulting Services (ACS)

Saint Paul, MN 55127

-- TRAFFIC DATA --

TH-95 at Chestnut St._2019 (Sat)

Ref Pt: 104+00.141

Data Prepared By: ACS

TURNING MOVEMENT COUNT

File Name : TH-95 at Chestnut St._2019 (Sat)

Site Code :

Start Date : 6/15/2019

Page No : 4

Start Time	TH-95 Southbound					Chestnut St Westbound					TH-95 Northbound					Chestnut St Eastbound					Int. Total
	Left	Thru	Right	Peds	App. Total	Left	Thru	Right	Peds	App. Total	Left	Thru	Right	Peds	App. Total	Left	Thru	Right	Peds	App. Total	
Peak Hour Analysis From 12:00 to 17:45 - Peak 1 of 1																					
Peak Hour for Entire Intersection Begins at 14:00																					
14:00	4	71	12	22	109	4	1	4	112	121	1	107	7	54	169	4	3	11	141	159	558
14:15	3	85	10	63	161	2	4	4	97	107	1	88	7	28	124	6	4	11	117	138	530
14:30	0	92	5	11	108	8	0	2	139	149	0	117	10	78	205	10	4	6	146	166	628
14:45	3	87	3	28	121	2	1	8	115	126	2	112	7	51	172	13	0	9	118	140	559
Total Volume	10	335	30	124	499	16	6	18	463	503	4	424	31	211	670	33	11	37	522	603	2275
% App. Total	2	67.1	6	24.8		3.2	1.2	3.6	92		0.6	63.3	4.6	31.5		5.5	1.8	6.1	86.6		
PHF	.625	.910	.625	.492	.775	.500	.375	.563	.833	.844	.500	.906	.775	.676	.817	.635	.688	.841	.894	.908	.906

