

Alliant Engineering

Minneapolis, MN 55415

--TRAFFIC DATA --

TH-10 at Upland Ave ELK RIVER

Ref.Pt.:

Alliant Eng.

TURN MOVEMENT COUNT

File Name : 401_TH 10 & Upland Ave

Site Code : 401

Start Date : 3/3/2016

Page No : 1

Groups Printed- Vehicles - Trucks

Start Time	Upland Ave NW Southbound				TH-10 Westbound				Upland Ave NW Northbound				TH-10 Eastbound				Int. Total
	Left	Thru	Rght	Other	Left	Thru	Rght	Other	Left	Thru	Rght	Other	Left	Thru	Rght	Other	
06:00	31	1	4	0	0	91	9	0	0	0	0	0	3	229	5	0	373
06:15	33	0	8	0	0	104	9	0	1	1	1	0	5	292	0	0	454
06:30	59	2	9	0	0	102	7	0	3	0	0	0	8	337	3	0	530
06:45	66	2	10	0	1	116	5	0	1	2	2	0	8	312	2	0	527
Total	189	5	31	0	1	413	30	0	5	3	3	0	24	1170	10	0	1884
07:00	51	2	9	0	0	130	9	0	1	1	0	0	4	309	3	0	519
07:15	54	1	18	0	0	141	8	0	0	2	3	0	6	283	2	0	518
07:30	50	3	13	0	1	147	9	0	1	2	2	0	4	308	1	0	541
07:45	46	5	14	0	0	183	9	0	1	2	0	0	11	271	4	0	546
Total	201	11	54	0	1	601	35	0	3	7	5	0	25	1171	10	0	2124
08:00	32	1	11	0	2	193	14	0	1	1	0	0	8	235	2	0	500
08:15	32	2	13	0	1	158	10	0	1	0	0	0	1	216	2	0	436
08:30	42	2	8	0	0	144	12	0	2	5	3	0	7	172	0	0	397
08:45	37	5	12	0	1	130	13	0	2	4	1	0	6	240	1	0	452
Total	143	10	44	0	4	625	49	0	6	10	4	0	22	863	5	0	1785
09:00	26	1	5	0	0	140	19	0	3	5	3	0	6	195	0	0	403
09:15	29	1	10	0	1	141	13	0	1	1	2	0	3	163	1	0	366
*** BREAK ***																	
Total	55	2	15	0	1	281	32	0	4	6	5	0	9	358	1	0	769
*** BREAK ***																	
10:30	26	0	4	0	0	137	14	0	1	1	0	0	6	169	1	0	359
10:45	19	1	6	0	1	135	17	0	4	1	0	0	8	165	0	0	357
Total	45	1	10	0	1	272	31	0	5	2	0	0	14	334	1	0	716
11:00	16	1	11	0	1	138	16	0	1	4	0	0	4	162	0	0	354
11:15	20	1	7	0	0	148	17	0	0	2	2	0	7	180	1	0	385
11:30	23	1	10	0	1	127	16	0	2	4	2	0	3	161	2	0	352
11:45	23	1	7	0	1	157	24	0	3	1	1	0	6	187	1	0	412
Total	82	4	35	0	3	570	73	0	6	11	5	0	20	690	4	0	1503
12:00	18	2	7	0	0	119	13	0	0	5	0	0	7	156	0	0	327
12:15	21	2	4	0	2	154	13	0	4	0	0	0	4	173	2	0	379
12:30	21	3	11	0	0	164	21	0	3	3	2	0	15	150	0	0	393
12:45	22	4	11	0	0	176	15	0	3	3	2	0	15	178	0	0	429
Total	82	11	33	0	2	613	62	0	10	11	4	0	41	657	2	0	1528
13:00	28	1	8	0	0	175	18	0	4	5	1	0	14	160	2	0	416
13:15	19	0	9	0	5	177	30	0	0	0	0	0	11	174	1	0	426
*** BREAK ***																	
Total	47	1	17	0	5	352	48	0	4	5	1	0	25	334	3	0	842
*** BREAK ***																	
14:30	24	3	7	0	1	216	21	0	1	6	2	0	12	219	1	0	513
14:45	30	1	9	0	0	198	28	0	2	6	1	0	8	212	1	0	496
Total	54	4	16	0	1	414	49	0	3	12	3	0	20	431	2	0	1009
15:00	21	4	14	0	2	244	37	0	5	10	0	0	7	226	0	0	570
15:15	22	5	16	0	2	321	20	0	2	7	2	0	6	215	0	0	618
15:30	17	4	11	0	0	341	33	0	5	6	2	0	18	246	0	0	683
15:45	22	2	13	0	1	358	49	0	1	12	2	0	16	270	0	0	746
Total	82	15	54	0	5	1264	139	0	13	35	6	0	47	957	0	0	2617
16:00	21	4	19	0	1	353	46	0	8	8	2	0	6	239	1	0	708
16:15	30	0	13	0	1	376	50	0	6	6	4	0	21	269	2	0	778
16:30	16	5	17	0	1	359	56	0	3	9	1	0	11	258	2	0	738

Alliant Engineering

Minneapolis, MN 55415

--TRAFFIC DATA --

TH-10 at Upland Ave ELK RIVER

Ref.Pt.:

Alliant Eng.

TURN MOVEMENT COUNT

File Name : 401_TH 10 & Upland Ave

Site Code : 401

Start Date : 3/3/2016

Page No : 2

Groups Printed- Vehicles - Trucks

Start Time	Upland Ave NW Southbound				TH-10 Westbound				Upland Ave NW Northbound				TH-10 Eastbound				Int. Total
	Left	Thru	Rght	Other	Left	Thru	Rght	Other	Left	Thru	Rght	Other	Left	Thru	Rght	Other	
16:45	21	6	20	0	0	378	61	0	2	2	0	0	17	337	0	0	844
Total	88	15	69	0	3	1466	213	0	19	25	7	0	55	1103	5	0	3068
17:00	29	2	16	0	5	375	54	0	2	11	5	0	13	236	0	0	748
17:15	20	0	13	0	1	354	48	0	4	5	3	0	16	230	0	0	694
17:30	23	7	9	0	3	322	45	0	3	8	2	0	13	191	0	0	626
17:45	14	3	9	0	2	271	50	0	0	5	0	0	11	240	0	0	605
Total	86	12	47	0	11	1322	197	0	9	29	10	0	53	897	0	0	2673
Grand Total	1154	91	425	0	38	8193	958	0	87	156	53	0	355	8965	43	0	20518
Apprch %	69.1	5.4	25.4	0	0.4	89.2	10.4	0	29.4	52.7	17.9	0	3.8	95.7	0.5	0	
Total %	5.6	0.4	2.1	0	0.2	39.9	4.7	0	0.4	0.8	0.3	0	1.7	43.7	0.2	0	
Vehicles	1135	88	413	0	38	7891	941	0	87	156	53	0	345	8674	43	0	19864
% Vehicles	98.4	96.7	97.2	0	100	96.3	98.2	0	100	100	100	0	97.2	96.8	100	0	96.8
Trucks	19	3	12	0	0	302	17	0	0	0	0	0	10	291	0	0	654
% Trucks	1.6	3.3	2.8	0	0	3.7	1.8	0	0	0	0	0	2.8	3.2	0	0	3.2

Alliant Engineering

Minneapolis, MN 55415

--TRAFFIC DATA --

TH-10 at Upland Ave ELK RIVER

Ref.Pt.:

Alliant Eng.

TURN MOVEMENT COUNT

File Name : 401_TH 10 & Upland Ave

Site Code : 401

Start Date : 3/3/2016

Page No : 3

Start Time	Upland Ave NW Southbound					TH-10 Westbound					Upland Ave NW Northbound					TH-10 Eastbound					Int. Total
	Left	Thru	Right	Other	App. Total	Left	Thru	Right	Other	App. Total	Left	Thru	Right	Other	App. Total	Left	Thru	Right	Other	App. Total	
Peak Hour Analysis From 06:00 to 11:45 - Peak 1 of 1																					
Peak Hour for Entire Intersection Begins at 07:00																					
07:00	51	2	9	0	62	0	130	9	0	139	1	1	0	0	2	4	309	3	0	316	519
07:15	54	1	18	0	73	0	141	8	0	149	0	2	3	0	5	6	283	2	0	291	518
07:30	50	3	13	0	66	1	147	9	0	157	1	2	2	0	5	4	308	1	0	313	541
07:45	46	5	14	0	65	0	183	9	0	192	1	2	0	0	3	11	271	4	0	286	546
Total Volume	201	11	54	0	266	1	601	35	0	637	3	7	5	0	15	25	1171	10	0	1206	2124
% App. Total	75.6	4.1	20.3	0		0.2	94.3	5.5	0		20	46.7	33.3	0		2.1	97.1	0.8	0		
PHF	.931	.550	.750	.000	.911	.250	.821	.972	.000	.829	.750	.875	.417	.000	.750	.568	.947	.625	.000	.954	.973

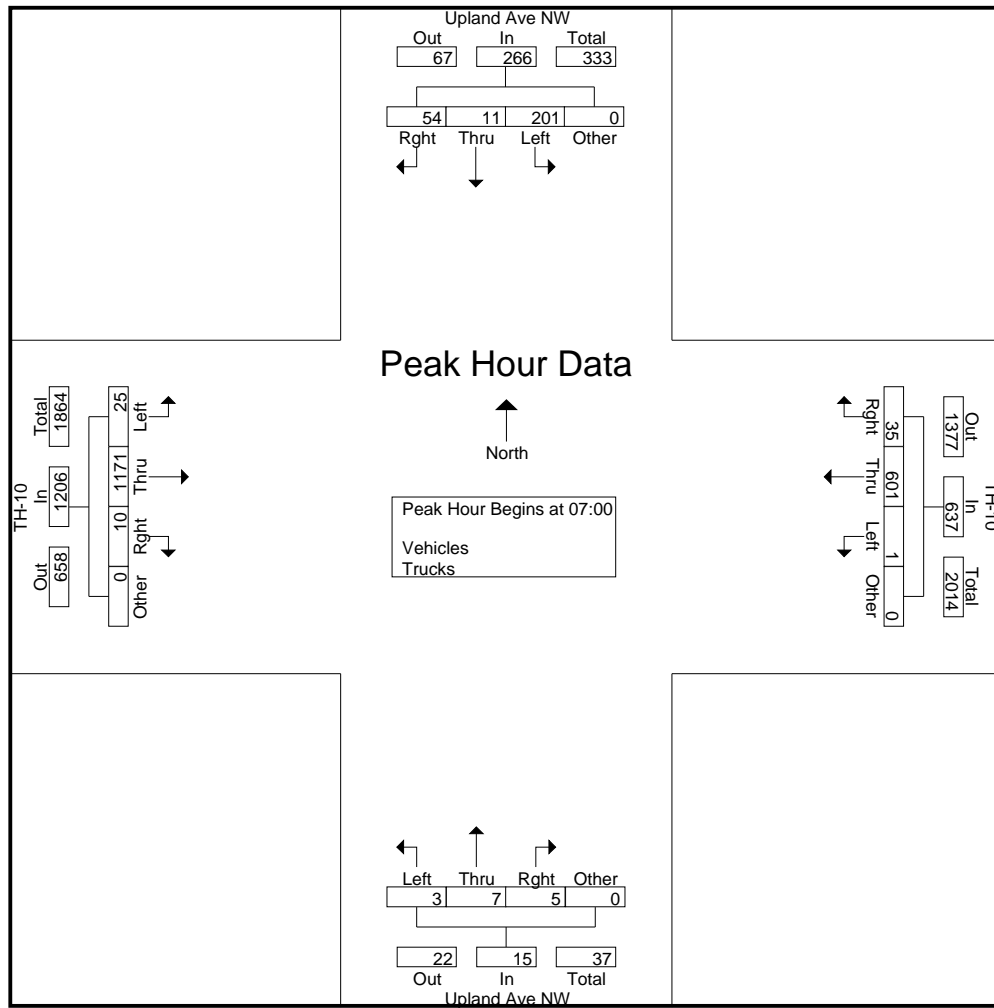

Alliant Engineering

Minneapolis, MN 55415

--TRAFFIC DATA --

TH-10 at Upland Ave ELK RIVER

Ref.Pt.:

Alliant Eng.

TURN MOVEMENT COUNT

File Name : 401_TH 10 & Upland Ave

Site Code : 401

Start Date : 3/3/2016

Page No : 4

Start Time	Upland Ave NW Southbound					TH-10 Westbound					Upland Ave NW Northbound					TH-10 Eastbound					Int. Total
	Left	Thru	Rght	Other	App. Total	Left	Thru	Rght	Other	App. Total	Left	Thru	Rght	Other	App. Total	Left	Thru	Rght	Other	App. Total	
Peak Hour Analysis From 12:00 to 17:45 - Peak 1 of 1																					
Peak Hour for Entire Intersection Begins at 16:15																					
16:15	30	0	13	0	43	1	376	50	0	427	6	6	4	0	16	21	269	2	0	292	778
16:30	16	5	17	0	38	1	359	56	0	416	3	9	1	0	13	11	258	2	0	271	738
16:45	21	6	20	0	47	0	378	61	0	439	2	2	0	0	4	17	337	0	0	354	844
17:00	29	2	16	0	47	5	375	54	0	434	2	11	5	0	18	13	236	0	0	249	748
Total Volume	96	13	66	0	175	7	1488	221	0	1716	13	28	10	0	51	62	1100	4	0	1166	3108
% App. Total	54.9	7.4	37.7	0		0.4	86.7	12.9	0		25.5	54.9	19.6	0		5.3	94.3	0.3	0		
PHF	.800	.542	.825	.000	.931	.350	.984	.906	.000	.977	.542	.636	.500	.000	.708	.738	.816	.500	.000	.823	.921

