



MINNESOTA DEPT OF TRANSPORTATION

TRAFFIC DATA COLLECTION - METRO

TH-52 AT 80TH ST E/CO.RD.28, EAST RAMP File Name : TH-52 AT 80TH ST E CO RD 28 E RAMP 2006
 REF.PT.: 122.789 Site Code : 00000000
 JAMAR # 632 DR Start Date : 11/16/2006
 TURN MOVEMENT COUNT Page No : 1

Groups Printed- Cars & Trucks

Start Time	LOOP FROM / RAMP TO TH-52 NB Southbound				CO.RD.28 / 80TH ST E. Westbound				BRODERICK BLVD Northbound				CO.RD.28 / 80TH ST E. Eastbound				Int. Total
	Left	Thru	Right	Peds	Left	Thru	Right	Peds	Left	Thru	Right	Peds	Left	Thru	Right	Peds	
06:00	1	0	1	0	2	32	39	0	1	4	1	0	23	18	3	0	125
06:15	3	0	1	0	0	23	54	0	1	7	0	0	36	28	5	0	158
06:30	3	0	1	0	1	52	73	0	2	7	2	0	38	60	7	0	246
06:45	4	0	5	0	2	50	87	0	3	9	0	0	59	69	6	0	294
Total	11	0	8	0	5	157	253	0	7	27	3	0	156	175	21	0	823
07:00	4	0	1	0	3	48	105	0	0	7	8	0	57	114	8	0	355
07:15	3	0	0	0	2	64	129	0	4	11	6	0	64	119	14	0	416
07:30	6	0	4	0	3	53	117	0	1	7	2	0	65	106	19	0	383
07:45	5	4	1	0	6	64	79	0	3	6	5	0	67	105	42	0	387
Total	18	4	6	0	14	229	430	0	8	31	21	0	253	444	83	0	1541
08:00	8	1	5	0	2	48	61	0	2	8	1	0	71	63	29	0	299
08:15	6	2	5	0	3	59	56	0	2	9	2	0	34	70	25	0	273
08:30	4	1	0	0	3	29	58	0	1	6	3	0	66	64	46	0	281
08:45	15	0	1	0	5	32	44	0	6	5	3	0	52	95	80	0	338
Total	33	4	11	0	13	168	219	0	11	28	9	0	223	292	180	0	1191
*** BREAK ***																	
15:00	2	0	1	0	2	54	61	0	6	20	4	0	33	91	18	0	292
15:15	7	1	3	0	2	72	57	0	13	21	7	0	39	111	25	0	358
15:30	7	1	5	0	4	66	69	0	14	19	5	0	50	133	23	0	396
15:45	3	0	4	0	3	50	66	0	5	19	12	0	44	125	27	0	358
Total	19	2	13	0	11	242	253	0	38	79	28	0	166	460	93	0	1404
16:00	4	0	1	0	3	61	66	0	4	12	9	0	41	140	21	0	362
16:15	2	0	3	0	6	62	55	0	10	11	3	0	56	160	37	0	405
16:30	4	0	3	0	1	73	59	0	8	16	10	0	51	145	28	0	398
16:45	5	0	6	0	2	73	53	0	10	10	12	0	49	174	31	0	425
Total	15	0	13	0	12	269	233	0	32	49	34	0	197	619	117	0	1590
17:00	2	0	0	0	3	61	66	0	7	9	15	0	63	140	38	0	404
17:15	8	0	4	0	0	73	49	0	1	11	6	0	58	206	48	0	464
17:30	8	0	2	0	5	67	63	0	7	6	16	0	43	179	64	0	460
17:45	10	0	7	0	5	72	59	0	11	6	11	0	51	219	47	0	498
Total	28	0	13	0	13	273	237	0	26	32	48	0	215	744	197	0	1826
Grand Total	124	10	64	0	68	1338	1625	0	122	246	143	0	1210	2734	691	0	8375
Apprch %	62.6	5.1	32.3	0	2.2	44.1	53.6	0	23.9	48.1	28	0	26.1	59	14.9	0	
Total %	1.5	0.1	0.8	0	0.8	16	19.4	0	1.5	2.9	1.7	0	14.4	32.6	8.3	0	



MINNESOTA DEPT OF TRANSPORTATION

TRAFFIC DATA COLLECTION - METRO

TH-52 AT 80TH ST E/CO.RD.28, EAST RAMP File Name : TH-52 AT 80TH ST E CO RD 28 E RAMP 2006
 REF.PT.: 122.789 Site Code : 00000000
 JAMAR # 632 DR Start Date : 11/16/2006
 TURN MOVEMENT COUNT Page No : 2

Start Time	LOOP FROM / RAMP TO TH-52 NB Southbound					CO.RD.28 / 80TH ST E. Westbound					BRODERICK BLVD Northbound					CO.RD.28 / 80TH ST E. Eastbound					Int. Total
	Left	Thru	Right	Peds	App. Total	Left	Thru	Right	Peds	App. Total	Left	Thru	Right	Peds	App. Total	Left	Thru	Right	Peds	App. Total	
Peak Hour Analysis From 06:00 to 08:45 - Peak 1 of 1																					
Peak Hour for Entire Intersection Begins at 07:00																					
07:00	4	0	1	0	5	3	48	105	0	156	0	7	8	0	15	57	114	8	0	179	355
07:15	3	0	0	0	3	2	64	129	0	195	4	11	6	0	21	64	119	14	0	197	416
07:30	6	0	4	0	10	3	53	117	0	173	1	7	2	0	10	65	106	19	0	190	383
07:45	5	4	1	0	10	6	64	79	0	149	3	6	5	0	14	67	105	42	0	214	387
Total Volume	18	4	6	0	28	14	229	430	0	673	8	31	21	0	60	253	444	83	0	780	1541
% App. Total	64.3	14.3	21.4	0		2.1	34	63.9	0		13.3	51.7	35	0		32.4	56.9	10.6	0		
PHF	.750	.250	.375	.000	.700	.583	.895	.833	.000	.863	.500	.705	.656	.000	.714	.944	.933	.494	.000	.911	.926

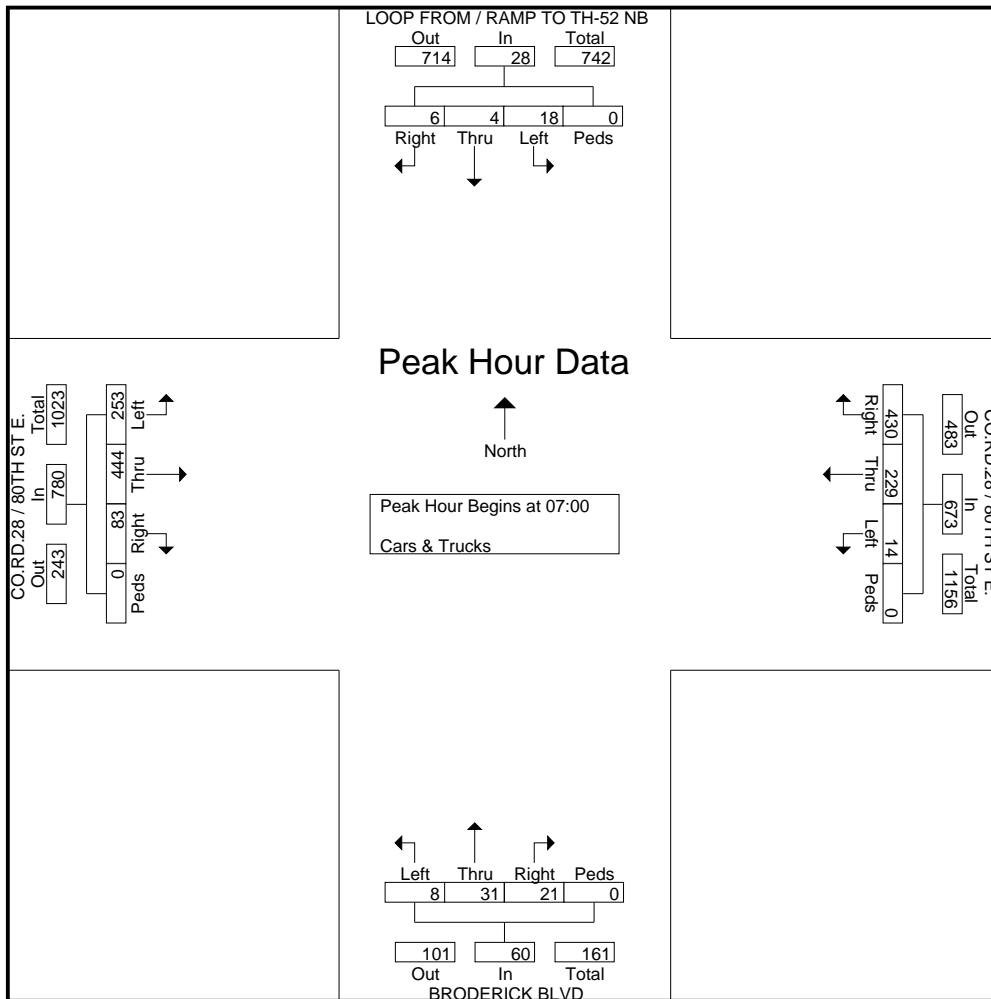



MINNESOTA DEPT OF TRANSPORTATION

TRAFFIC DATA COLLECTION - METRO

TH-52 AT 80TH ST E/CO.RD.28, EAST RAMP File Name : TH-52 AT 80TH ST E CO RD 28 E RAMP 2006
 REF.PT.: 122.789 Site Code : 00000000
 JAMAR # 632 DR Start Date : 11/16/2006
 TURN MOVEMENT COUNT Page No : 3

Start Time	LOOP FROM / RAMP TO TH-52 NB Southbound					CO.RD.28 / 80TH ST E. Westbound					BRODERICK BLVD Northbound					CO.RD.28 / 80TH ST E. Eastbound					Int. Total
	Left	Thru	Right	Peds	App. Total	Left	Thru	Right	Peds	App. Total	Left	Thru	Right	Peds	App. Total	Left	Thru	Right	Peds	App. Total	

Peak Hour Analysis From 15:00 to 17:45 - Peak 1 of 1
 Peak Hour for Entire Intersection Begins at 17:00

17:00	2	0	0	0	2	3	61	66	0	130	7	9	15	0	31	63	140	38	0	241	404
17:15	8	0	4	0	12	0	73	49	0	122	1	11	6	0	18	58	206	48	0	312	464
17:30	8	0	2	0	10	5	67	63	0	135	7	6	16	0	29	43	179	64	0	286	460
17:45	10	0	7	0	17	5	72	59	0	136	11	6	11	0	28	51	219	47	0	317	498
Total Volume	28	0	13	0	41	13	273	237	0	523	26	32	48	0	106	215	744	197	0	1156	1826
% App. Total	68.3	0	31.7	0		2.5	52.2	45.3	0		24.5	30.2	45.3	0		18.6	64.4	17	0		
PHF	.700	.000	.464	.000	.603	.650	.935	.898	.000	.961	.591	.727	.750	.000	.855	.853	.849	.770	.000	.912	.917

