

# ALLIANT ENGINEERING INC.

733 S Marquette Ave #700, Minneapolis, MN 55402

TH 61 & Parkway Dr (Frost Ave)  
 Ref Pt: 140+00.268  
 data by: Alliant Inc  
 TURN MOVEMENT COUNT

File Name : 501\_TH 61 and Parkway Drive (Frost Avenue)  
 Site Code : 1735484  
 Start Date : 11/12/2019  
 Page No : 1

Groups Printed- Cars - Trucks

Start Time	TH 61 Southbound					Frost Ave Westbound					TH 61 Northbound					Parkway Drive Eastbound					Int. Total
	Right	Thru	Left	Peds	App. Total	Right	Thru	Left	Peds	App. Total	Right	Thru	Left	Peds	App. Total	Right	Thru	Left	Peds	App. Total	
06:00 AM	6	54	2	0	62	6	18	2	0	26	2	43	0	0	45	1	5	3	0	9	142
06:15 AM	16	79	3	0	98	11	28	4	0	43	2	61	0	0	63	0	2	5	0	7	211
06:30 AM	39	126	3	0	168	5	35	5	0	45	2	63	0	0	65	1	5	14	0	20	298
06:45 AM	49	179	4	0	232	5	27	4	0	36	0	95	0	0	95	0	12	18	0	30	393
<b>Total</b>	<b>110</b>	<b>438</b>	<b>12</b>	<b>0</b>	<b>560</b>	<b>27</b>	<b>108</b>	<b>15</b>	<b>0</b>	<b>150</b>	<b>6</b>	<b>262</b>	<b>0</b>	<b>0</b>	<b>268</b>	<b>2</b>	<b>24</b>	<b>40</b>	<b>0</b>	<b>66</b>	<b>1044</b>
07:00 AM	70	191	10	0	271	8	48	4	0	60	4	98	1	0	103	0	5	8	0	13	447
07:15 AM	103	218	9	0	330	10	53	5	0	68	6	82	1	0	89	0	13	18	0	31	518
07:30 AM	95	207	18	0	320	8	61	4	0	73	5	110	0	0	115	1	20	18	0	39	547
07:45 AM	84	267	10	0	361	5	35	6	0	46	1	115	0	0	116	0	14	22	0	36	559
<b>Total</b>	<b>352</b>	<b>883</b>	<b>47</b>	<b>0</b>	<b>1282</b>	<b>31</b>	<b>197</b>	<b>19</b>	<b>0</b>	<b>247</b>	<b>16</b>	<b>405</b>	<b>2</b>	<b>0</b>	<b>423</b>	<b>1</b>	<b>52</b>	<b>66</b>	<b>0</b>	<b>119</b>	<b>2071</b>
08:00 AM	94	189	10	0	293	19	46	7	0	72	6	128	0	0	134	1	8	17	0	26	525
08:15 AM	78	167	8	0	253	6	27	3	0	36	2	83	2	0	87	1	6	18	0	25	401
08:30 AM	61	163	11	0	235	8	24	7	0	39	5	100	0	0	105	0	7	28	0	35	414
08:45 AM	36	123	11	0	170	9	27	5	0	41	9	95	3	0	107	0	8	20	0	28	346
<b>Total</b>	<b>269</b>	<b>642</b>	<b>40</b>	<b>0</b>	<b>951</b>	<b>42</b>	<b>124</b>	<b>22</b>	<b>0</b>	<b>188</b>	<b>22</b>	<b>406</b>	<b>5</b>	<b>0</b>	<b>433</b>	<b>2</b>	<b>29</b>	<b>83</b>	<b>0</b>	<b>114</b>	<b>1686</b>
09:00 AM	24	130	5	0	159	11	27	2	0	40	11	85	2	0	98	1	10	24	0	35	332
09:15 AM	19	88	17	0	124	18	27	7	1	53	6	93	1	0	100	0	12	15	0	27	304
*** BREAK ***																					
<b>Total</b>	<b>43</b>	<b>218</b>	<b>22</b>	<b>0</b>	<b>283</b>	<b>29</b>	<b>54</b>	<b>9</b>	<b>1</b>	<b>93</b>	<b>17</b>	<b>178</b>	<b>3</b>	<b>0</b>	<b>198</b>	<b>1</b>	<b>22</b>	<b>39</b>	<b>0</b>	<b>62</b>	<b>636</b>
*** BREAK ***																					
10:30 AM	27	83	12	0	122	8	11	1	0	20	11	91	0	0	102	0	14	25	0	39	283
10:45 AM	28	79	19	0	126	10	14	7	0	31	6	93	2	0	101	1	16	22	0	39	297
<b>Total</b>	<b>55</b>	<b>162</b>	<b>31</b>	<b>0</b>	<b>248</b>	<b>18</b>	<b>25</b>	<b>8</b>	<b>0</b>	<b>51</b>	<b>17</b>	<b>184</b>	<b>2</b>	<b>0</b>	<b>203</b>	<b>1</b>	<b>30</b>	<b>47</b>	<b>0</b>	<b>78</b>	<b>580</b>
11:00 AM	20	75	12	0	107	14	15	9	0	38	5	98	1	0	104	0	11	18	0	29	278
11:15 AM	23	76	14	0	113	17	17	5	0	39	9	91	1	0	101	0	9	26	0	35	288
11:30 AM	20	108	15	0	143	19	13	5	0	37	3	106	2	0	111	1	17	21	0	39	330
11:45 AM	16	103	15	0	134	5	9	3	0	17	9	73	1	0	83	1	14	17	0	32	266
<b>Total</b>	<b>79</b>	<b>362</b>	<b>56</b>	<b>0</b>	<b>497</b>	<b>55</b>	<b>54</b>	<b>22</b>	<b>0</b>	<b>131</b>	<b>26</b>	<b>368</b>	<b>5</b>	<b>0</b>	<b>399</b>	<b>2</b>	<b>51</b>	<b>82</b>	<b>0</b>	<b>135</b>	<b>1162</b>
12:00 PM	32	106	12	0	150	11	17	3	0	31	11	90	2	0	103	0	11	20	0	31	315
12:15 PM	24	92	9	0	125	7	16	3	0	26	12	103	0	0	115	0	13	27	0	40	306
12:30 PM	28	116	20	0	164	6	17	8	0	31	7	102	2	0	111	0	19	15	0	34	340
12:45 PM	24	104	15	0	143	13	16	9	0	38	11	93	2	0	106	0	19	27	0	46	333
<b>Total</b>	<b>108</b>	<b>418</b>	<b>56</b>	<b>0</b>	<b>582</b>	<b>37</b>	<b>66</b>	<b>23</b>	<b>0</b>	<b>126</b>	<b>41</b>	<b>388</b>	<b>6</b>	<b>0</b>	<b>435</b>	<b>0</b>	<b>62</b>	<b>89</b>	<b>0</b>	<b>151</b>	<b>1294</b>
01:00 PM	30	98	16	0	144	16	9	2	0	27	9	113	1	0	123	0	8	23	0	31	325
01:15 PM	11	99	18	0	128	14	20	4	0	38	5	101	0	0	106	0	16	19	0	35	307
*** BREAK ***																					
<b>Total</b>	<b>41</b>	<b>197</b>	<b>34</b>	<b>0</b>	<b>272</b>	<b>30</b>	<b>29</b>	<b>6</b>	<b>0</b>	<b>65</b>	<b>14</b>	<b>214</b>	<b>1</b>	<b>0</b>	<b>229</b>	<b>0</b>	<b>24</b>	<b>42</b>	<b>0</b>	<b>66</b>	<b>632</b>
*** BREAK ***																					
02:30 PM	19	154	17	0	190	9	14	5	0	28	7	155	0	0	162	1	22	36	0	59	439
02:45 PM	41	143	28	0	212	8	20	7	0	35	12	167	1	0	180	2	21	34	0	57	484
<b>Total</b>	<b>60</b>	<b>297</b>	<b>45</b>	<b>0</b>	<b>402</b>	<b>17</b>	<b>34</b>	<b>12</b>	<b>0</b>	<b>63</b>	<b>19</b>	<b>322</b>	<b>1</b>	<b>0</b>	<b>342</b>	<b>3</b>	<b>43</b>	<b>70</b>	<b>0</b>	<b>116</b>	<b>923</b>
03:00 PM	37	128	46	0	211	9	8	3	0	20	8	162	1	0	171	1	39	44	0	84	486
03:15 PM	31	173	56	0	260	9	11	4	0	24	8	157	3	0	168	0	39	53	0	92	544
03:30 PM	30	174	40	0	244	13	19	5	0	37	12	197	1	0	210	2	55	59	0	116	607

# ALLIANT ENGINEERING INC.

733 S Marquette Ave #700, Minneapolis, MN 55402

TH 61 & Parkway Dr (Frost Ave)  
 Ref Pt: 140+00.268  
 data by: Alliant Inc  
 TURN MOVEMENT COUNT

File Name : 501\_TH 61 and Parkway Drive (Frost Avenue)  
 Site Code : 1735484  
 Start Date : 11/12/2019  
 Page No : 2

Groups Printed- Cars - Trucks

Start Time	TH 61 Southbound					Frost Ave Westbound					TH 61 Northbound					Parkway Drive Eastbound					Int. Total
	Right	Thru	Left	Peds	App. Total	Right	Thru	Left	Peds	App. Total	Right	Thru	Left	Peds	App. Total	Right	Thru	Left	Peds	App. Total	
03:45 PM	43	157	36	0	236	7	29	3	0	39	11	213	1	0	225	0	43	60	0	103	603
Total	141	632	178	0	951	38	67	15	0	120	39	729	6	0	774	3	176	216	0	395	2240
04:00 PM	39	170	39	0	248	7	38	4	0	49	8	241	5	0	254	0	36	84	0	120	671
04:15 PM	44	163	33	0	240	16	23	11	0	50	7	320	2	0	329	1	66	142	0	209	828
04:30 PM	40	187	39	0	266	6	22	3	0	31	10	339	2	0	351	0	50	104	1	155	803
04:45 PM	38	137	32	0	207	11	20	3	0	34	13	357	1	0	371	0	45	149	0	194	806
Total	161	657	143	0	961	40	103	21	0	164	38	1257	10	0	1305	1	197	479	1	678	3108
05:00 PM	31	152	35	0	218	6	20	5	0	31	8	353	2	0	363	3	53	118	0	174	786
05:15 PM	34	125	25	0	184	11	24	3	0	38	12	342	0	0	354	0	45	119	0	164	740
05:30 PM	37	143	30	0	210	10	19	8	0	37	16	276	3	0	295	0	31	89	0	120	662
05:45 PM	25	124	23	0	172	13	16	5	0	34	10	191	3	0	204	0	30	57	0	87	497
Total	127	544	113	0	784	40	79	21	0	140	46	1162	8	0	1216	3	159	383	0	545	2685
Grand Total	1546	5450	777	0	7773	404	940	193	1	1538	301	5875	49	0	6225	19	869	1636	1	2525	18061
Apprch %	19.9	70.1	10	0		26.3	61.1	12.5	0.1		4.8	94.4	0.8	0		0.8	34.4	64.8	0		
Total %	8.6	30.2	4.3	0	43	2.2	5.2	1.1	0	8.5	1.7	32.5	0.3	0	34.5	0.1	4.8	9.1	0	14	
Cars	1520	5345	752	0	7617	384	900	190	1	1475	289	5769	47	0	6105	14	829	1621	1	2465	17662
% Cars	98.3	98.1	96.8	0	98	95	95.7	98.4	100	95.9	96	98.2	95.9	0	98.1	73.7	95.4	99.1	100	97.6	97.8
Trucks	26	105	25	0	156	20	40	3	0	63	12	106	2	0	120	5	40	15	0	60	399
% Trucks	1.7	1.9	3.2	0	2	5	4.3	1.6	0	4.1	4	1.8	4.1	0	1.9	26.3	4.6	0.9	0	2.4	2.2

# ALLIANT ENGINEERING INC.

733 S Marquette Ave #700, Minneapolis, MN 55402

TH 61 & Parkway Dr (Frost Ave)  
 Ref Pt: 140+00.268  
 data by: Alliant Inc  
 TURN MOVEMENT COUNT

File Name : 501\_TH 61 and Parkway Drive (Frost Avenue)  
 Site Code : 1735484  
 Start Date : 11/12/2019  
 Page No : 3

Start Time	TH 61 Southbound					Frost Ave Westbound					TH 61 Northbound					Parkway Drive Eastbound					Int. Total
	Right	Thru	Left	Peds	App. Total	Right	Thru	Left	Peds	App. Total	Right	Thru	Left	Peds	App. Total	Right	Thru	Left	Peds	App. Total	
Peak Hour Analysis From 06:00 AM to 09:45 AM - Peak 1 of 1																					
Peak Hour for Entire Intersection Begins at 07:15 AM																					
07:15 AM	103	218	9	0	330	10	53	5	0	68	6	82	1	0	89	0	13	18	0	31	518
07:30 AM	95	207	18	0	320	8	61	4	0	73	5	110	0	0	115	1	20	18	0	39	547
07:45 AM	84	267	10	0	361	5	35	6	0	46	1	115	0	0	116	0	14	22	0	36	559
08:00 AM	94	189	10	0	293	19	46	7	0	72	6	128	0	0	134	1	8	17	0	26	525
Total Volume	376	881	47	0	1304	42	195	22	0	259	18	435	1	0	454	2	55	75	0	132	2149
% App. Total	28.8	67.6	3.6	0		16.2	75.3	8.5	0		4	95.8	0.2	0		1.5	41.7	56.8	0		
PHF	.913	.825	.653	.000	.903	.553	.799	.786	.000	.887	.750	.850	.250	.000	.847	.500	.688	.852	.000	.846	.961

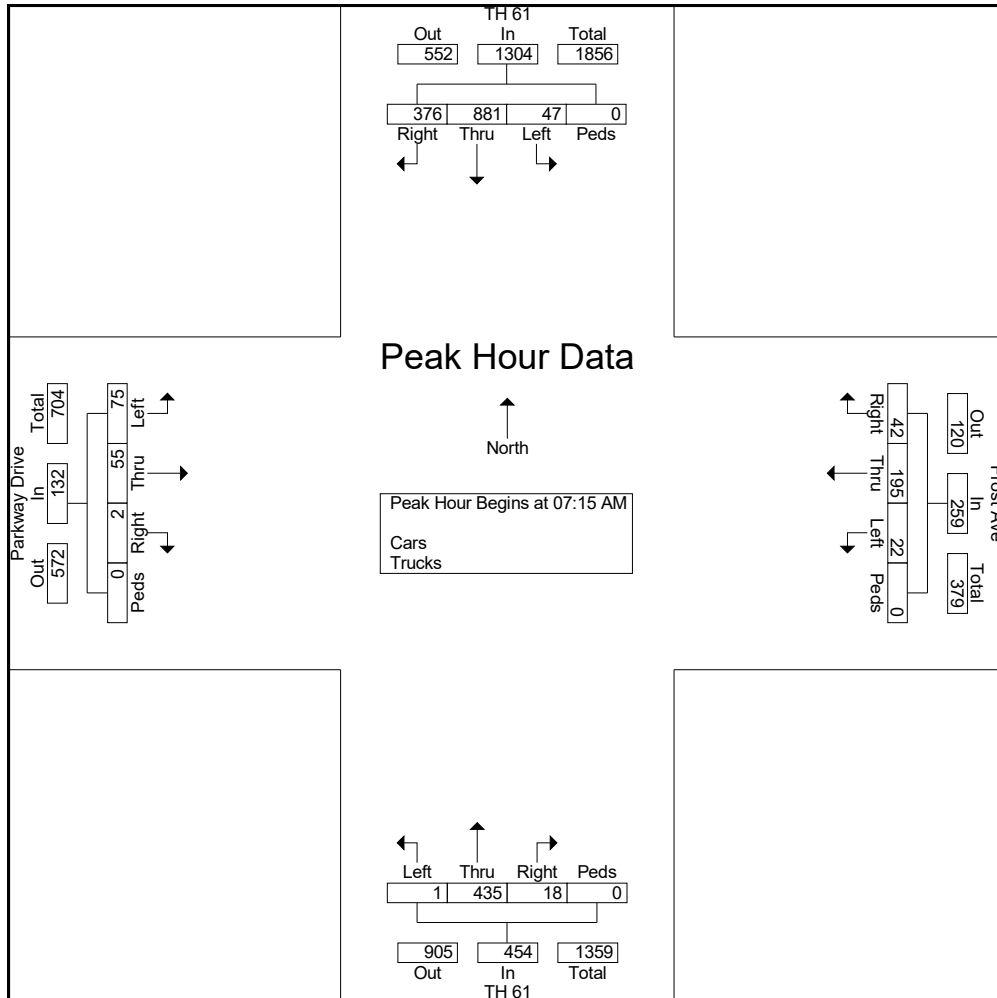

# ALLIANT ENGINEERING INC.

733 S Marquette Ave #700, Minneapolis, MN 55402

TH 61 & Parkway Dr (Frost Ave)  
 Ref Pt: 140+00.268  
 data by: Alliant Inc  
 TURN MOVEMENT COUNT

File Name : 501\_TH 61 and Parkway Drive (Frost Avenue)  
 Site Code : 1735484  
 Start Date : 11/12/2019  
 Page No : 4

Start Time	TH 61 Southbound					Frost Ave Westbound					TH 61 Northbound					Parkway Drive Eastbound					Int. Total
	Right	Thru	Left	Peds	App. Total	Right	Thru	Left	Peds	App. Total	Right	Thru	Left	Peds	App. Total	Right	Thru	Left	Peds	App. Total	
Peak Hour Analysis From 10:00 AM to 01:45 PM - Peak 1 of 1																					
Peak Hour for Entire Intersection Begins at 12:30 PM																					
12:30 PM	28	116	20	0	164	6	17	8	0	31	7	102	2	0	111	0	19	15	0	34	340
12:45 PM	24	104	15	0	143	13	16	9	0	38	11	93	2	0	106	0	19	27	0	46	333
01:00 PM	30	98	16	0	144	16	9	2	0	27	9	113	1	0	123	0	8	23	0	31	325
01:15 PM	11	99	18	0	128	14	20	4	0	38	5	101	0	0	106	0	16	19	0	35	307
Total Volume	93	417	69	0	579	49	62	23	0	134	32	409	5	0	446	0	62	84	0	146	1305
% App. Total	16.1	72	11.9	0		36.6	46.3	17.2	0		7.2	91.7	1.1	0		0	42.5	57.5	0		
PHF	.775	.899	.863	.000	.883	.766	.775	.639	.000	.882	.727	.905	.625	.000	.907	.000	.816	.778	.000	.793	.960

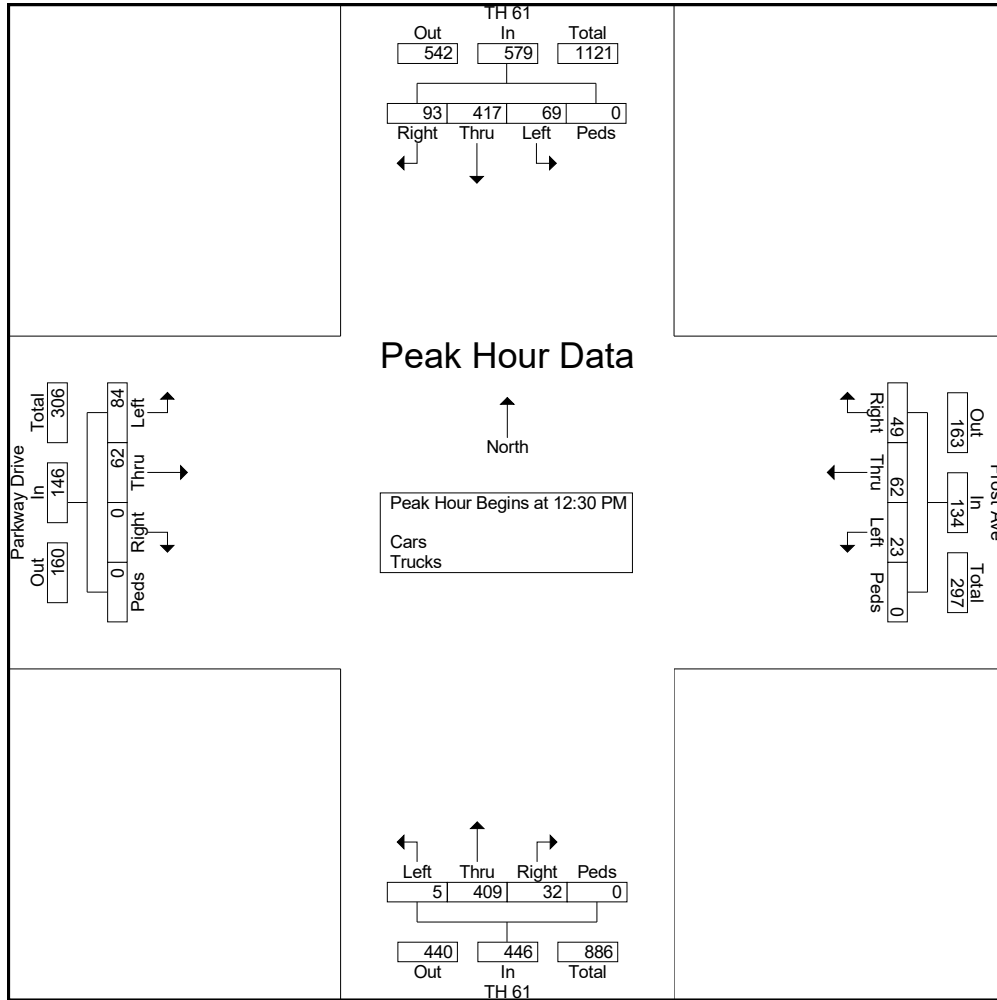

# ALLIANT ENGINEERING INC.

733 S Marquette Ave #700, Minneapolis, MN 55402

TH 61 & Parkway Dr (Frost Ave)  
 Ref Pt: 140+00.268  
 data by: Alliant Inc  
 TURN MOVEMENT COUNT

File Name : 501\_TH 61 and Parkway Drive (Frost Avenue)  
 Site Code : 1735484  
 Start Date : 11/12/2019  
 Page No : 5

Start Time	TH 61 Southbound					Frost Ave Westbound					TH 61 Northbound					Parkway Drive Eastbound					Int. Total
	Right	Thru	Left	Peds	App. Total	Right	Thru	Left	Peds	App. Total	Right	Thru	Left	Peds	App. Total	Right	Thru	Left	Peds	App. Total	
Peak Hour Analysis From 02:00 PM to 05:45 PM - Peak 1 of 1																					
Peak Hour for Entire Intersection Begins at 04:15 PM																					
04:15 PM	44	163	33	0	240	16	23	11	0	50	7	320	2	0	329	1	66	142	0	209	828
04:30 PM	40	187	39	0	266	6	22	3	0	31	10	339	2	0	351	0	50	104	1	155	803
04:45 PM	38	137	32	0	207	11	20	3	0	34	13	357	1	0	371	0	45	149	0	194	806
05:00 PM	31	152	35	0	218	6	20	5	0	31	8	353	2	0	363	3	53	118	0	174	786
Total Volume	153	639	139	0	931	39	85	22	0	146	38	1369	7	0	1414	4	214	513	1	732	3223
% App. Total	16.4	68.6	14.9	0		26.7	58.2	15.1	0		2.7	96.8	0.5	0		0.5	29.2	70.1	0.1		
PHF	.869	.854	.891	.000	.875	.609	.924	.500	.000	.730	.731	.959	.875	.000	.953	.333	.811	.861	.250	.876	.973

