

ALLIANT ENGINEERING INC.

733 S Marquette Ave #700, Minneapolis, MN 55402

TH 61 & Frenchman Rd (Muller Dr)
 Ref Pt: 152+00.578
 data by: Alliant Inc
 TURN MOVEMENT COUNT

File Name : 524_TH 61 and Frenchman Road (Muller Drive)
 Site Code : 1736327
 Start Date : 11/7/2019
 Page No : 1

Groups Printed- Cars - Trucks

Start Time	TH 61 Southbound					Muller Dr Westbound					TH 61 Northbound					Frenchman Rd Eastbound					Int. Total
	Right	Thru	Left	Peds	App. Total	Right	Thru	Left	Peds	App. Total	Right	Thru	Left	Peds	App. Total	Right	Thru	Left	Peds	App. Total	
05:00 AM	36	18	0	0	54	1	1	0	0	2	0	3	18	0	21	18	1	5	0	24	101
05:15 AM	68	27	0	0	95	0	0	0	0	0	0	6	27	0	33	27	0	7	0	34	162
05:30 AM	97	55	0	0	152	0	0	0	0	0	0	6	33	0	39	29	0	10	0	39	230
05:45 AM	133	84	0	0	217	0	0	0	0	0	0	17	46	0	63	39	0	22	0	61	341
Total	334	184	0	0	518	1	1	0	0	2	0	32	124	0	156	113	1	44	0	158	834
06:00 AM	175	104	0	0	279	0	0	0	0	0	0	18	54	0	72	48	0	26	0	74	425
06:15 AM	161	147	0	0	308	0	0	2	0	2	0	29	47	0	76	53	0	33	0	86	472
06:30 AM	136	159	0	0	295	0	0	0	0	0	0	24	70	0	94	87	0	26	0	113	502
06:45 AM	143	183	0	0	326	0	0	0	0	0	0	40	64	0	104	117	0	43	0	160	590
Total	615	593	0	0	1208	0	0	2	0	2	0	111	235	0	346	305	0	128	0	433	1989
07:00 AM	149	178	1	0	328	0	1	0	0	1	0	41	73	0	114	120	2	31	0	153	596
07:15 AM	168	177	0	0	345	0	0	0	0	0	1	54	75	0	130	110	0	39	0	149	624
07:30 AM	157	164	0	0	321	0	1	0	0	1	1	52	92	0	145	112	0	30	0	142	609
07:45 AM	122	137	2	0	261	0	1	0	0	1	0	51	87	0	138	90	1	47	0	138	538
Total	596	656	3	0	1255	0	3	0	0	3	2	198	327	0	527	432	3	147	0	582	2367
08:00 AM	96	125	0	0	221	1	1	1	0	3	0	62	80	0	142	81	0	49	0	130	496
08:15 AM	100	73	0	0	173	0	0	0	0	0	0	56	75	0	131	66	1	35	0	102	406
08:30 AM	80	104	0	0	184	1	1	1	0	3	0	45	61	0	106	64	0	45	0	109	402
08:45 AM	86	97	1	0	184	0	1	0	0	1	1	57	58	0	116	67	0	46	0	113	414
Total	362	399	1	0	762	2	3	2	0	7	1	220	274	0	495	278	1	175	0	454	1718
09:00 AM	82	100	1	0	183	0	1	0	0	1	0	54	71	0	125	69	0	37	0	106	415
09:15 AM	63	84	0	0	147	0	0	1	0	1	0	39	77	0	116	62	1	51	0	114	378
09:30 AM	66	59	0	0	125	0	0	2	0	2	0	46	61	0	107	67	0	26	0	93	327
09:45 AM	55	66	0	0	121	0	1	1	0	2	1	48	69	0	118	65	0	52	0	117	358
Total	266	309	1	0	576	0	2	4	0	6	1	187	278	0	466	263	1	166	0	430	1478
10:00 AM	48	82	0	0	130	0	0	2	0	2	1	54	60	0	115	58	0	31	0	89	336
10:15 AM	54	64	0	0	118	1	0	2	0	3	0	53	53	0	106	61	0	48	1	110	337
10:30 AM	41	65	0	0	106	0	0	0	0	0	0	63	50	0	113	64	0	46	0	110	329
10:45 AM	64	67	0	0	131	1	0	0	0	1	0	63	70	0	133	50	0	44	2	96	361
Total	207	278	0	0	485	2	0	4	0	6	1	233	233	0	467	233	0	169	3	405	1363
11:00 AM	65	62	0	0	127	0	0	0	0	0	1	75	77	0	153	69	0	45	0	114	394
11:15 AM	62	64	0	1	127	0	2	1	1	4	1	58	67	0	126	79	4	67	0	150	407
11:30 AM	66	70	1	0	137	0	0	1	0	1	2	65	80	0	147	62	0	59	0	121	406
11:45 AM	64	85	0	0	149	1	1	1	1	4	1	58	64	0	123	78	1	43	0	122	398
Total	257	281	1	1	540	1	3	3	2	9	5	256	288	0	549	288	5	214	0	507	1605
12:00 PM	57	69	0	0	126	0	0	0	1	1	0	77	63	0	140	69	1	45	0	115	382
12:15 PM	63	76	0	0	139	0	0	0	0	0	2	67	73	0	142	78	0	77	0	155	436
12:30 PM	64	60	2	0	126	0	2	1	0	3	1	64	54	0	119	74	0	53	0	127	375
12:45 PM	64	68	0	0	132	0	1	1	0	2	1	81	75	0	157	71	1	56	0	128	419
Total	248	273	2	0	523	0	3	2	1	6	4	289	265	0	558	292	2	231	0	525	1612
01:00 PM	52	57	1	0	110	2	2	0	0	4	0	74	71	0	145	73	2	59	0	134	393
01:15 PM	55	57	1	0	113	0	0	0	0	0	0	64	59	0	123	81	1	53	0	135	371
01:30 PM	54	71	0	0	125	1	1	0	0	2	0	69	72	0	141	60	1	45	0	106	374
01:45 PM	45	65	0	0	110	0	2	0	0	2	0	85	78	0	163	74	0	74	0	148	423
Total	206	250	2	0	458	3	5	0	0	8	0	292	280	0	572	288	4	231	0	523	1561

ALLIANT ENGINEERING INC.

733 S Marquette Ave #700, Minneapolis, MN 55402

TH 61 & Frenchman Rd (Muller Dr)
 Ref Pt: 152+00.578
 data by: Alliant Inc
 TURN MOVEMENT COUNT

File Name : 524_TH 61 and Frenchman Road (Muller Drive)
 Site Code : 1736327
 Start Date : 11/7/2019
 Page No : 2

Groups Printed- Cars - Trucks

Start Time	TH 61 Southbound					Muller Dr Westbound					TH 61 Northbound					Frenchman Rd Eastbound					Int. Total
	Right	Thru	Left	Peds	App. Total	Right	Thru	Left	Peds	App. Total	Right	Thru	Left	Peds	App. Total	Right	Thru	Left	Peds	App. Total	
02:00 PM	57	90	1	0	148	1	1	0	0	2	2	86	77	0	165	77	0	57	0	134	449
02:15 PM	43	51	0	0	94	0	0	0	0	0	0	82	77	0	159	68	0	67	0	135	388
02:30 PM	65	64	0	1	130	0	0	0	0	0	0	107	85	0	192	86	1	56	0	143	465
02:45 PM	49	85	2	0	136	0	0	0	0	0	2	91	92	0	185	75	2	88	0	165	486
Total	214	290	3	1	508	1	1	0	0	2	4	366	331	0	701	306	3	268	0	577	1788
03:00 PM	57	68	1	0	126	1	0	1	0	2	0	110	94	0	204	69	0	92	0	161	493
03:15 PM	71	59	0	0	130	1	1	1	0	3	1	156	114	0	271	76	0	105	0	181	585
03:30 PM	98	88	1	0	187	0	0	0	0	0	1	137	99	0	237	82	0	124	0	206	630
03:45 PM	71	93	0	0	164	1	0	1	1	3	2	137	102	0	241	103	2	118	0	223	631
Total	297	308	2	0	607	3	1	3	1	8	4	540	409	0	953	330	2	439	0	771	2339
04:00 PM	92	79	0	0	171	1	1	0	0	2	1	144	131	0	276	124	0	119	0	243	692
04:15 PM	63	70	0	0	133	0	0	0	0	0	1	151	140	0	292	101	1	104	0	206	631
04:30 PM	89	93	0	0	182	0	0	0	0	0	1	149	118	0	268	108	0	138	0	246	696
04:45 PM	88	77	0	0	165	0	0	1	0	1	0	139	102	0	241	126	0	141	0	267	674
Total	332	319	0	0	651	1	1	1	0	3	3	583	491	0	1077	459	1	502	0	962	2693
05:00 PM	82	81	0	0	163	1	0	0	0	1	0	157	120	0	277	117	0	112	0	229	670
05:15 PM	75	81	1	0	157	0	0	2	0	2	1	121	100	0	222	107	0	129	0	236	617
05:30 PM	60	78	0	0	138	0	0	0	0	0	1	122	95	0	218	102	0	114	0	216	572
05:45 PM	76	69	0	0	145	1	0	0	0	1	0	130	75	0	205	83	0	98	0	181	532
Total	293	309	1	0	603	2	0	2	0	4	2	530	390	0	922	409	0	453	0	862	2391
06:00 PM	48	66	0	0	114	0	2	0	0	2	0	93	86	0	179	91	0	78	0	169	464
06:15 PM	49	45	1	0	95	0	0	0	0	0	0	73	65	0	138	74	0	68	0	142	375
06:30 PM	51	39	0	0	90	0	0	0	0	0	0	68	58	0	126	81	0	64	0	145	361
06:45 PM	30	34	0	0	64	1	0	0	0	1	0	58	52	0	110	50	0	54	0	104	279
Total	178	184	1	0	363	1	2	0	0	3	0	292	261	0	553	296	0	264	0	560	1479
07:00 PM	45	48	0	0	93	0	0	1	0	1	2	58	53	0	113	46	1	68	0	115	322
07:15 PM	32	37	1	0	70	0	1	0	0	1	1	48	62	0	111	40	0	45	0	85	267
07:30 PM	27	31	0	0	58	0	0	0	0	0	1	49	44	0	94	42	1	56	0	99	251
07:45 PM	26	31	0	0	57	0	0	0	0	0	1	56	46	0	103	38	1	34	0	73	233
Total	130	147	1	0	278	0	1	1	0	2	5	211	205	0	421	166	3	203	0	372	1073
08:00 PM	23	29	0	0	52	0	0	0	0	0	0	44	39	0	83	38	0	35	0	73	208
08:15 PM	24	28	1	0	53	0	1	1	0	2	0	49	39	0	88	35	0	46	0	81	224
08:30 PM	13	14	0	0	27	1	0	0	0	1	0	31	53	0	84	36	1	40	0	77	189
08:45 PM	22	18	1	0	41	0	0	1	0	1	0	36	44	0	80	30	1	28	0	59	181
Total	82	89	2	0	173	1	1	2	0	4	0	160	175	0	335	139	2	149	0	290	802
09:00 PM	13	28	1	0	42	1	0	1	0	2	0	46	40	0	86	36	0	27	0	63	193
09:15 PM	21	20	0	0	41	0	0	0	0	0	0	32	26	0	58	30	1	17	0	48	147
09:30 PM	14	11	0	0	25	0	0	0	0	0	0	25	17	0	42	15	0	40	0	55	122
09:45 PM	11	9	0	0	20	0	0	0	0	0	0	23	12	0	35	16	0	19	0	35	90
Total	59	68	1	0	128	1	0	1	0	2	0	126	95	0	221	97	1	103	0	201	552
Grand Total	4676	4937	21	2	9636	19	27	27	4	77	32	4626	4661	0	9319	4694	29	3886	3	8612	27644
Apprch %	48.5	51.2	0.2	0		24.7	35.1	35.1	5.2		0.3	49.6	50	0		54.5	0.3	45.1	0		
Total %	16.9	17.9	0.1	0	34.9	0.1	0.1	0.1	0	0.3	0.1	16.7	16.9	0	33.7	17	0.1	14.1	0	31.2	
Cars	4549	4749	21	2	9321	18	24	27	4	73	29	4453	4195	0	8677	4204	26	3762	3	7995	26066
% Cars	97.3	96.2	100	100	96.7	94.7	88.9	100	100	94.8	90.6	96.3	90	0	93.1	89.6	89.7	96.8	100	92.8	94.3
Trucks	127	188	0	0	315	1	3	0	0	4	3	173	466	0	642	490	3	124	0	617	1578
% Trucks	2.7	3.8	0	0	3.3	5.3	11.1	0	0	5.2	9.4	3.7	10	0	6.9	10.4	10.3	3.2	0	7.2	5.7

ALLIANT ENGINEERING INC.

733 S Marquette Ave #700, Minneapolis, MN 55402

TH 61 & Frenchman Rd (Muller Dr)
 Ref Pt: 152+00.578
 data by: Alliant Inc
 TURN MOVEMENT COUNT

File Name : 524_TH 61 and Frenchman Road (Muller Drive)
 Site Code : 1736327
 Start Date : 11/7/2019
 Page No : 3

Start Time	TH 61 Southbound					Muller Dr Westbound					TH 61 Northbound					Frenchman Rd Eastbound					Int. Total
	Right	Thru	Left	Peds	App. Total	Right	Thru	Left	Peds	App. Total	Right	Thru	Left	Peds	App. Total	Right	Thru	Left	Peds	App. Total	
Peak Hour Analysis From 05:00 AM to 08:45 AM - Peak 1 of 1																					
Peak Hour for Entire Intersection Begins at 06:45 AM																					
06:45 AM	143	183	0	0	326	0	0	0	0	0	0	40	64	0	104	117	0	43	0	160	590
07:00 AM	149	178	1	0	328	0	1	0	0	1	0	41	73	0	114	120	2	31	0	153	596
07:15 AM	168	177	0	0	345	0	0	0	0	0	1	54	75	0	130	110	0	39	0	149	624
07:30 AM	157	164	0	0	321	0	1	0	0	1	1	52	92	0	145	112	0	30	0	142	609
Total Volume	617	702	1	0	1320	0	2	0	0	2	2	187	304	0	493	459	2	143	0	604	2419
% App. Total	46.7	53.2	0.1	0		0	100	0	0		0.4	37.9	61.7	0		76	0.3	23.7	0		
PHF	.918	.959	.250	.000	.957	.000	.500	.000	.000	.500	.500	.866	.826	.000	.850	.956	.250	.831	.000	.944	.969

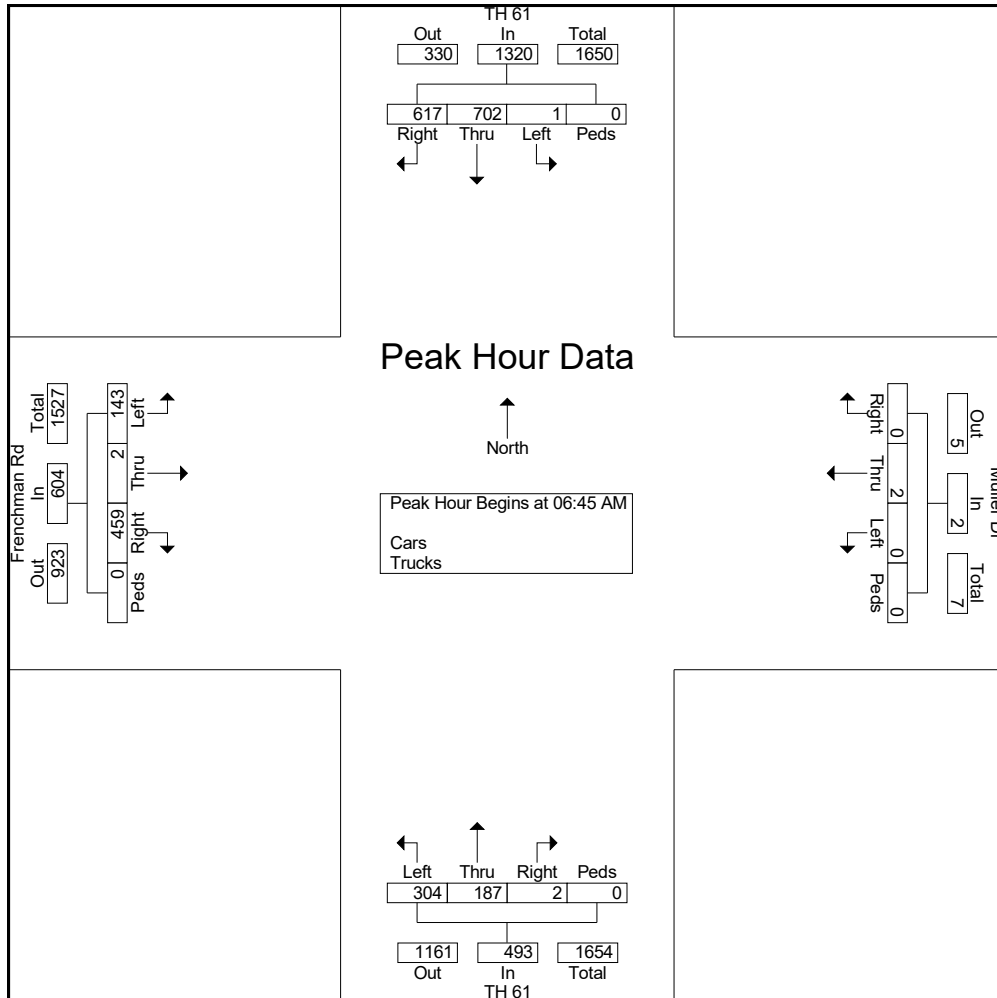

ALLIANT ENGINEERING INC.

733 S Marquette Ave #700, Minneapolis, MN 55402

TH 61 & Frenchman Rd (Muller Dr)
 Ref Pt: 152+00.578
 data by: Alliant Inc
 TURN MOVEMENT COUNT

File Name : 524_TH 61 and Frenchman Road (Muller Drive)
 Site Code : 1736327
 Start Date : 11/7/2019
 Page No : 4

Start Time	TH 61 Southbound					Muller Dr Westbound					TH 61 Northbound					Frenchman Rd Eastbound					Int. Total
	Right	Thru	Left	Peds	App. Total	Right	Thru	Left	Peds	App. Total	Right	Thru	Left	Peds	App. Total	Right	Thru	Left	Peds	App. Total	
Peak Hour Analysis From 09:00 AM to 12:45 PM - Peak 1 of 1																					
Peak Hour for Entire Intersection Begins at 11:30 AM																					
11:30 AM	66	70	1	0	137	0	0	1	0	1	2	65	80	0	147	62	0	59	0	121	406
11:45 AM	64	85	0	0	149	1	1	1	1	4	1	58	64	0	123	78	1	43	0	122	398
12:00 PM	57	69	0	0	126	0	0	0	1	1	0	77	63	0	140	69	1	45	0	115	382
12:15 PM	63	76	0	0	139	0	0	0	0	0	2	67	73	0	142	78	0	77	0	155	436
Total Volume	250	300	1	0	551	1	1	2	2	6	5	267	280	0	552	287	2	224	0	513	1622
% App. Total	45.4	54.4	0.2	0		16.7	16.7	33.3	33.3		0.9	48.4	50.7	0		55.9	0.4	43.7	0		
PHF	.947	.882	.250	.000	.924	.250	.250	.500	.500	.375	.625	.867	.875	.000	.939	.920	.500	.727	.000	.827	.930

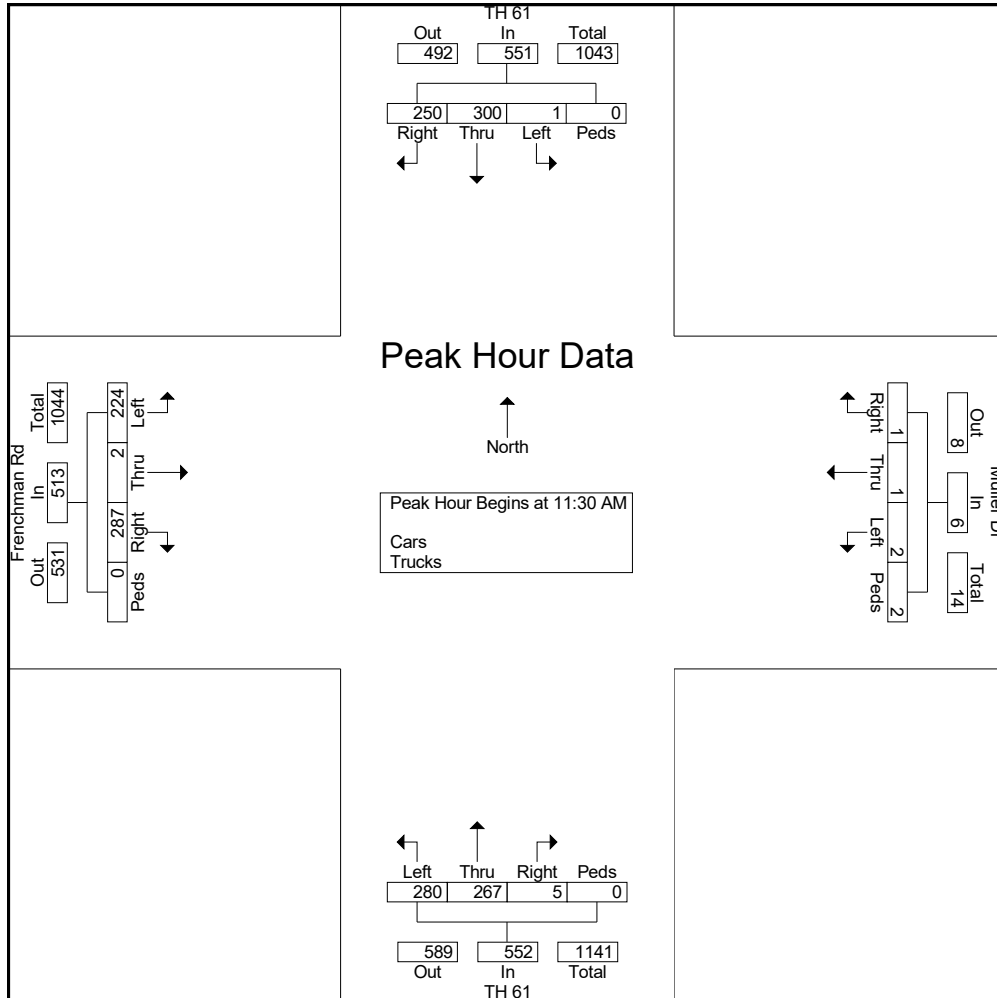

ALLIANT ENGINEERING INC.

733 S Marquette Ave #700, Minneapolis, MN 55402

TH 61 & Frenchman Rd (Muller Dr)
 Ref Pt: 152+00.578
 data by: Alliant Inc
 TURN MOVEMENT COUNT

File Name : 524_TH 61 and Frenchman Road (Muller Drive)
 Site Code : 1736327
 Start Date : 11/7/2019
 Page No : 5

Start Time	TH 61 Southbound					Muller Dr Westbound					TH 61 Northbound					Frenchman Rd Eastbound					Int. Total
	Right	Thru	Left	Peds	App. Total	Right	Thru	Left	Peds	App. Total	Right	Thru	Left	Peds	App. Total	Right	Thru	Left	Peds	App. Total	
Peak Hour Analysis From 01:00 PM to 04:45 PM - Peak 1 of 1																					
Peak Hour for Entire Intersection Begins at 04:00 PM																					
04:00 PM	92	79	0	0	171	1	1	0	0	2	1	144	131	0	276	124	0	119	0	243	692
04:15 PM	63	70	0	0	133	0	0	0	0	0	1	151	140	0	292	101	1	104	0	206	631
04:30 PM	89	93	0	0	182	0	0	0	0	0	1	149	118	0	268	108	0	138	0	246	696
04:45 PM	88	77	0	0	165	0	0	1	0	1	0	139	102	0	241	126	0	141	0	267	674
Total Volume	332	319	0	0	651	1	1	1	0	3	3	583	491	0	1077	459	1	502	0	962	2693
% App. Total	51	49	0	0		33.3	33.3	33.3	0		0.3	54.1	45.6	0		47.7	0.1	52.2	0		
PHF	.902	.858	.000	.000	.894	.250	.250	.250	.000	.375	.750	.965	.877	.000	.922	.911	.250	.890	.000	.901	.967

