

MN Dept of Transportation

TRAFFIC DATA COLLECTION - Metro

TH-8 at TH-95, North Jct - Taylors Falls
 Ref.Pt.: 022.071
 video JN
 TURN MOVEMENT COUNT

File Name : TH-8 at TH-95 N jct 2015
 Site Code :
 Start Date : 10/3/2015
 Page No : 1

Groups Printed- Cars + - Trucks

Start Time	TH-95 Southbound				TH-8 Westbound				Park Entrance Northbound				TH-8 Eastbound				Int. Total
	Left	Thru	Right	Peds	Left	Thru	Right	Peds	Left	Thru	Right	Peds	Left	Thru	Right	Peds	
06:00	7	0	2	0	0	16	8	0	0	0	1	0	2	10	1	0	47
06:15	9	1	4	0	0	29	11	0	0	0	0	0	2	19	0	0	75
06:30	12	0	1	0	0	24	17	0	0	0	0	0	2	11	1	0	68
06:45	18	0	1	0	1	18	10	0	1	0	1	0	0	22	1	0	73
Total	46	1	8	0	1	87	46	0	1	0	2	0	6	62	3	0	263
07:00	10	1	2	0	0	21	16	0	0	0	0	0	0	41	2	0	93
07:15	26	0	5	0	0	27	14	0	0	1	0	0	1	36	0	0	110
07:30	27	0	0	0	0	49	25	0	1	0	0	0	4	46	1	0	153
07:45	30	1	5	0	0	42	26	2	0	2	0	0	5	49	1	0	163
Total	93	2	12	0	0	139	81	2	1	3	0	0	10	172	4	0	519
08:00	27	1	5	0	1	39	18	0	0	0	0	0	7	62	2	0	162
08:15	40	1	2	0	0	49	41	3	1	0	0	0	6	79	5	0	227
08:30	30	10	1	0	0	38	31	0	2	0	0	0	7	76	4	0	199
08:45	56	1	12	0	1	57	38	0	0	1	1	0	7	94	5	0	273
Total	153	13	20	0	2	183	128	3	3	1	1	0	27	311	16	0	861
***** BREAK *****																	
15:00	68	5	31	0	3	110	70	2	18	12	9	0	39	132	23	0	522
15:15	68	9	40	0	7	142	82	4	9	11	3	0	47	98	25	1	546
15:30	82	2	37	0	7	120	75	0	10	11	5	0	22	62	16	0	449
15:45	101	5	41	0	10	133	77	0	13	5	4	0	12	15	6	2	424
Total	319	21	149	0	27	505	304	6	50	39	21	0	120	307	70	3	1941
16:00	78	9	48	1	9	145	63	0	21	7	5	1	8	33	8	4	440
16:15	85	7	36	0	3	118	74	0	5	13	4	0	18	75	8	4	450
16:30	96	4	37	0	1	124	67	0	7	5	1	0	27	105	10	5	489
16:45	63	5	26	0	6	120	71	0	8	9	8	0	30	83	17	0	446
Total	322	25	147	1	19	507	275	0	41	34	18	1	83	296	43	13	1825
17:00	59	3	42	0	4	105	77	2	20	10	6	0	24	84	7	1	444
17:15	45	8	36	0	8	108	61	2	8	2	3	0	28	78	14	0	401
17:30	62	8	26	0	9	112	55	0	9	8	2	0	17	55	15	1	379
17:45	66	3	33	0	1	96	58	0	7	6	3	2	22	63	3	0	363
Total	232	22	137	0	22	421	251	4	44	26	14	2	91	280	39	2	1587
Grand Total	1165	84	473	1	71	1842	1085	15	140	103	56	3	337	1428	175	18	6996
Apprch %	67.6	4.9	27.5	0.1	2.4	61.1	36	0.5	46.4	34.1	18.5	1	17.2	72.9	8.9	0.9	
Total %	16.7	1.2	6.8	0	1	26.3	15.5	0.2	2	1.5	0.8	0	4.8	20.4	2.5	0.3	
Cars +	1145	83	469	1	71	1826	1065	15	140	103	56	3	335	1408	175	18	6913
% Cars +	98.3	98.8	99.2	100	100	99.1	98.2	100	100	100	100	100	99.4	98.6	100	100	98.8
Trucks	20	1	4	0	0	16	20	0	0	0	0	0	2	20	0	0	83
% Trucks	1.7	1.2	0.8	0	0	0.9	1.8	0	0	0	0	0	0.6	1.4	0	0	1.2

MN Dept of Transportation

TRAFFIC DATA COLLECTION - Metro

TH-8 at TH-95, North Jct - Taylors Falls
 Ref.Pt.: 022.071
 video JN
 TURN MOVEMENT COUNT

File Name : TH-8 at TH-95 N jct 2015
 Site Code :
 Start Date : 10/3/2015
 Page No : 2

Start Time	TH-95 Southbound					TH-8 Westbound					Park Entrance Northbound					TH-8 Eastbound					Int. Total
	Left	Thru	Right	Peds	App. Total	Left	Thru	Right	Peds	App. Total	Left	Thru	Right	Peds	App. Total	Left	Thru	Right	Peds	App. Total	
Peak Hour Analysis From 06:00 to 11:45 - Peak 1 of 1																					
Peak Hour for Entire Intersection Begins at 08:00																					
08:00	27	1	5	0	33	1	39	18	0	58	0	0	0	0	0	7	62	2	0	71	162
08:15	40	1	2	0	43	0	49	41	3	93	1	0	0	0	1	6	79	5	0	90	227
08:30	30	10	1	0	41	0	38	31	0	69	2	0	0	0	2	7	76	4	0	87	199
08:45	56	1	12	0	69	1	57	38	0	96	0	1	1	0	2	7	94	5	0	106	273
Total Volume	153	13	20	0	186	2	183	128	3	316	3	1	1	0	5	27	311	16	0	354	861
% App. Total	82.3	7	10.8	0		0.6	57.9	40.5	0.9		60	20	20	0		7.6	87.9	4.5	0		
PHF	.683	.325	.417	.000	.674	.500	.803	.780	.250	.823	.375	.250	.250	.000	.625	.964	.827	.800	.000	.835	.788

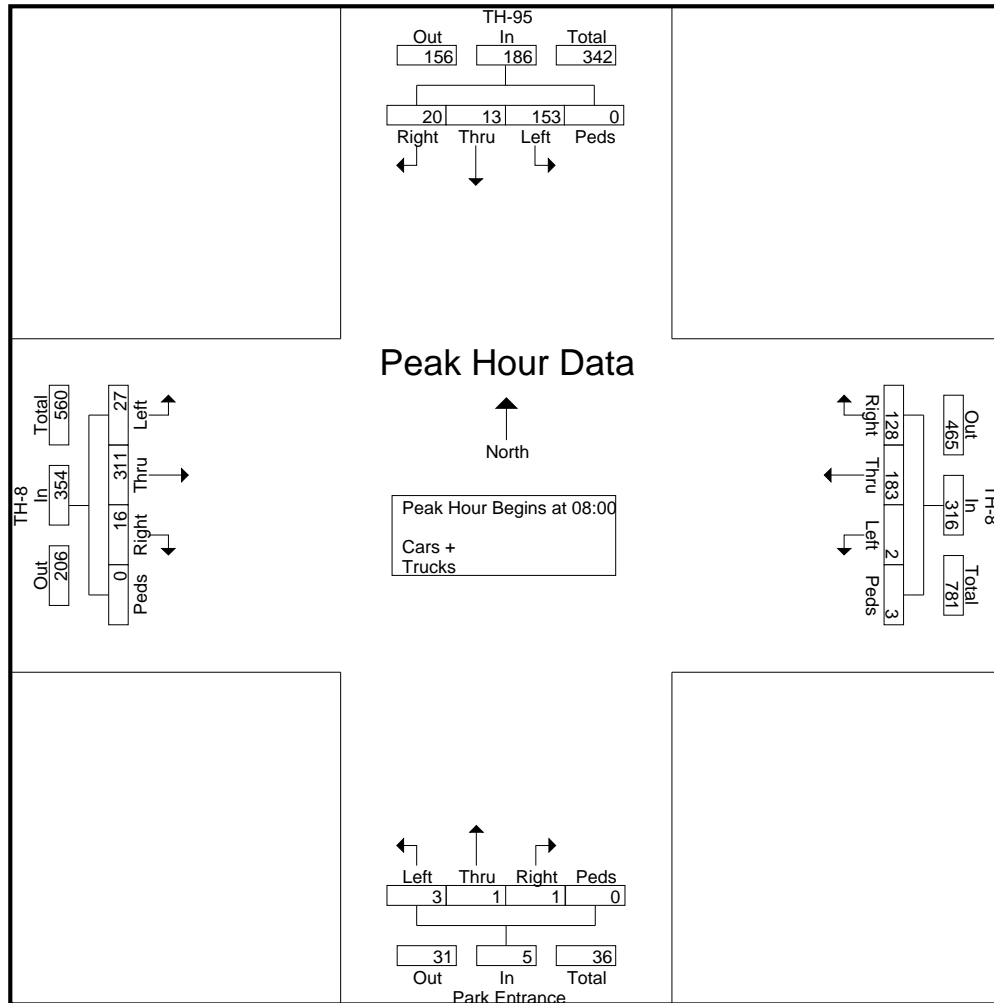

MN Dept of Transportation

TRAFFIC DATA COLLECTION - Metro

TH-8 at TH-95, North Jct - Taylors Falls
 Ref.Pt.: 022.071
 video JN
 TURN MOVEMENT COUNT

File Name : TH-8 at TH-95 N jct 2015
 Site Code :
 Start Date : 10/3/2015
 Page No : 3

Start Time	TH-95 Southbound					TH-8 Westbound					Park Entrance Northbound					TH-8 Eastbound					Int. Total
	Left	Thru	Right	Peds	App. Total	Left	Thru	Right	Peds	App. Total	Left	Thru	Right	Peds	App. Total	Left	Thru	Right	Peds	App. Total	
Peak Hour Analysis From 12:00 to 17:45 - Peak 1 of 1																					
Peak Hour for Entire Intersection Begins at 15:00																					
15:00	68	5	31	0	104	3	110	70	2	185	18	12	9	0	39	39	132	23	0	194	522
15:15	68	9	40	0	117	7	142	82	4	235	9	11	3	0	23	47	98	25	1	171	546
15:30	82	2	37	0	121	7	120	75	0	202	10	11	5	0	26	22	62	16	0	100	449
15:45	101	5	41	0	147	10	133	77	0	220	13	5	4	0	22	12	15	6	2	35	424
Total Volume	319	21	149	0	489	27	505	304	6	842	50	39	21	0	110	120	307	70	3	500	1941
% App. Total	65.2	4.3	30.5	0		3.2	60	36.1	0.7		45.5	35.5	19.1	0		24	61.4	14	0.6		
PHF	.790	.583	.909	.000	.832	.675	.889	.927	.375	.896	.694	.813	.583	.000	.705	.638	.581	.700	.375	.644	.889

