

**MINNESOTA DEPARTMENT OF TRANSPORTATION**  
**TRAFFIC DATA COLLECTION - Metro**

Location: Hopkins Xrd and I-394 N Ramp File Name : TMC\_#16 Hopkins Xrd & I-394 N Ramp\_20181002  
 Data Prepared By: ACS Site Code :  
 TURNING MOVEMENT COUNT Start Date : 10/2/2018  
 Page No : 1

Groups Printed- Cars - Trucks

Start Time	Southbound				Westbound				Northbound				Eastbound				Int. Total
	Left	Thru	Right	Peds	Left	Thru	Right	Peds	Left	Thru	Right	Peds	Left	Thru	Right	Peds	
06:00	5	16	0	0	42	0	11	0	0	15	6	0	0	0	0	0	95
06:15	6	34	0	0	41	0	32	0	0	22	13	0	0	0	0	0	148
06:30	4	40	0	0	42	0	30	0	0	28	25	0	0	0	0	0	169
06:45	7	54	0	0	45	0	27	0	0	53	22	0	0	0	0	0	208
Total	22	144	0	0	170	0	100	0	0	118	66	0	0	0	0	0	620
07:00	6	77	0	0	36	0	38	0	0	56	8	0	0	0	0	0	221
07:15	15	112	0	0	69	0	59	0	0	80	33	0	0	0	0	0	368
07:30	13	128	0	0	78	0	71	0	0	83	50	0	0	0	0	0	423
07:45	11	120	0	0	64	0	76	0	0	119	50	0	0	0	0	0	440
Total	45	437	0	0	247	0	244	0	0	338	141	0	0	0	0	0	1452
08:00	12	147	0	0	92	0	98	0	0	114	30	0	0	0	0	0	493
08:15	17	180	0	0	66	0	72	0	0	103	41	0	0	0	0	0	479
08:30	21	163	0	0	63	0	78	0	0	101	31	0	0	0	0	0	457
08:45	5	108	0	0	69	0	68	0	0	91	29	0	0	0	0	0	370
Total	55	598	0	0	290	0	316	0	0	409	131	0	0	0	0	0	1799
*** BREAK ***																	
11:00	15	90	0	0	28	0	65	0	0	83	26	0	0	0	0	0	307
11:15	18	78	0	0	33	0	92	0	0	99	26	0	0	0	0	0	346
11:30	32	120	0	0	19	0	98	0	0	81	31	0	0	0	0	0	381
11:45	29	102	0	0	36	0	84	0	0	92	28	0	0	0	0	0	371
Total	94	390	0	0	116	0	339	0	0	355	111	0	0	0	0	0	1405
12:00	29	125	0	0	33	0	83	0	0	93	32	0	0	0	0	0	395
12:15	26	121	0	0	36	0	62	0	0	97	39	0	0	0	0	0	381
12:30	20	107	0	0	27	0	75	0	0	90	36	0	0	0	0	0	355
12:45	25	108	0	0	35	0	99	0	0	92	42	0	0	0	0	0	401
Total	100	461	0	0	131	0	319	0	0	372	149	0	0	0	0	0	1532
*** BREAK ***																	
15:00	22	109	0	0	54	0	62	0	0	85	44	0	0	0	0	0	376
15:15	19	102	0	0	39	0	59	0	0	91	43	0	0	0	0	0	353
15:30	21	96	0	0	67	0	86	0	0	101	47	0	0	0	0	0	418
15:45	17	108	0	0	45	0	88	0	0	121	50	0	0	0	0	0	429
Total	79	415	0	0	205	0	295	0	0	398	184	0	0	0	0	0	1576
16:00	29	119	0	0	62	0	99	0	0	125	46	0	0	0	0	0	480
16:15	17	152	0	0	63	0	74	0	0	146	52	0	0	0	0	0	504
16:30	20	159	0	0	80	0	67	0	0	135	42	0	0	0	0	0	503
16:45	20	151	0	0	62	0	58	0	0	134	46	0	0	0	0	0	471
Total	86	581	0	0	267	0	298	0	0	540	186	0	0	0	0	0	1958
17:00	30	166	0	0	74	0	77	0	0	142	50	0	0	0	0	0	539
17:15	39	170	0	0	55	0	82	0	0	139	54	0	0	0	0	0	539

**MINNESOTA DEPARTMENT OF TRANSPORTATION**  
**TRAFFIC DATA COLLECTION - Metro**

Location: Hopkins Xrd and I-394 N Ramp File Name : TMC\_#16 Hopkins Xrd & I-394 N Ramp\_20181002  
 Data Prepared By: ACS Site Code :  
 TURNING MOVEMENT COUNT Start Date : 10/2/2018  
 Page No : 2

Groups Printed- Cars - Trucks

Start Time	Southbound				Westbound				Northbound				Eastbound				Int. Total
	Left	Thru	Right	Peds	Left	Thru	Right	Peds	Left	Thru	Right	Peds	Left	Thru	Right	Peds	
17:30	10	147	0	0	94	0	83	0	0	116	39	0	0	0	0	0	489
17:45	21	119	0	0	62	0	83	1	0	128	39	0	0	0	0	0	453
Total	100	602	0	0	285	0	325	1	0	525	182	0	0	0	0	0	2020
Grand Total	581	3628	0	0	1711	0	2236	1	0	3055	1150	0	0	0	0	0	12362
Apprch %	13.8	86.2	0	0	43.3	0	56.6	0	0	72.7	27.3	0	0	0	0	0	
Total %	4.7	29.3	0	0	13.8	0	18.1	0	0	24.7	9.3	0	0	0	0	0	
Cars	567	3515	0	0	1639	0	2182	1	0	2965	1131	0	0	0	0	0	12000
% Cars	97.6	96.9	0	0	95.8	0	97.6	100	0	97.1	98.3	0	0	0	0	0	97.1
Trucks	14	113	0	0	72	0	54	0	0	90	19	0	0	0	0	0	362
% Trucks	2.4	3.1	0	0	4.2	0	2.4	0	0	2.9	1.7	0	0	0	0	0	2.9

# MINNESOTA DEPARTMENT OF TRANSPORTATION

## TRAFFIC DATA COLLECTION - Metro

Location: Hopkins Xrd and I-394 N Ramp File Name : TMC\_#16 Hopkins Xrd & I-394 N Ramp\_20181002  
 Data Prepared By: ACS Site Code :  
 TURNING MOVEMENT COUNT Start Date : 10/2/2018  
 Page No : 3

Start Time	Southbound					Westbound					Northbound					Eastbound					Int. Total
	Left	Thru	Right	Peds	App. Total	Left	Thru	Right	Peds	App. Total	Left	Thru	Right	Peds	App. Total	Left	Thru	Right	Peds	App. Total	
Peak Hour Analysis From 06:00 to 08:45 - Peak 1 of 1																					
Peak Hour for Entire Intersection Begins at 07:45																					
07:45	11	120	0	0	131	64	0	76	0	140	0	119	50	0	169	0	0	0	0	0	440
08:00	12	147	0	0	159	92	0	98	0	190	0	114	30	0	144	0	0	0	0	0	493
08:15	17	180	0	0	197	66	0	72	0	138	0	103	41	0	144	0	0	0	0	0	479
08:30	21	163	0	0	184	63	0	78	0	141	0	101	31	0	132	0	0	0	0	0	457
Total Volume	61	610	0	0	671	285	0	324	0	609	0	437	152	0	589	0	0	0	0	0	1869
% App. Total	9.1	90.9	0	0		46.8	0	53.2	0		0	74.2	25.8	0		0	0	0	0		
PHF	.726	.847	.000	.000	.852	.774	.000	.827	.000	.801	.000	.918	.760	.000	.871	.000	.000	.000	.000	.000	.948

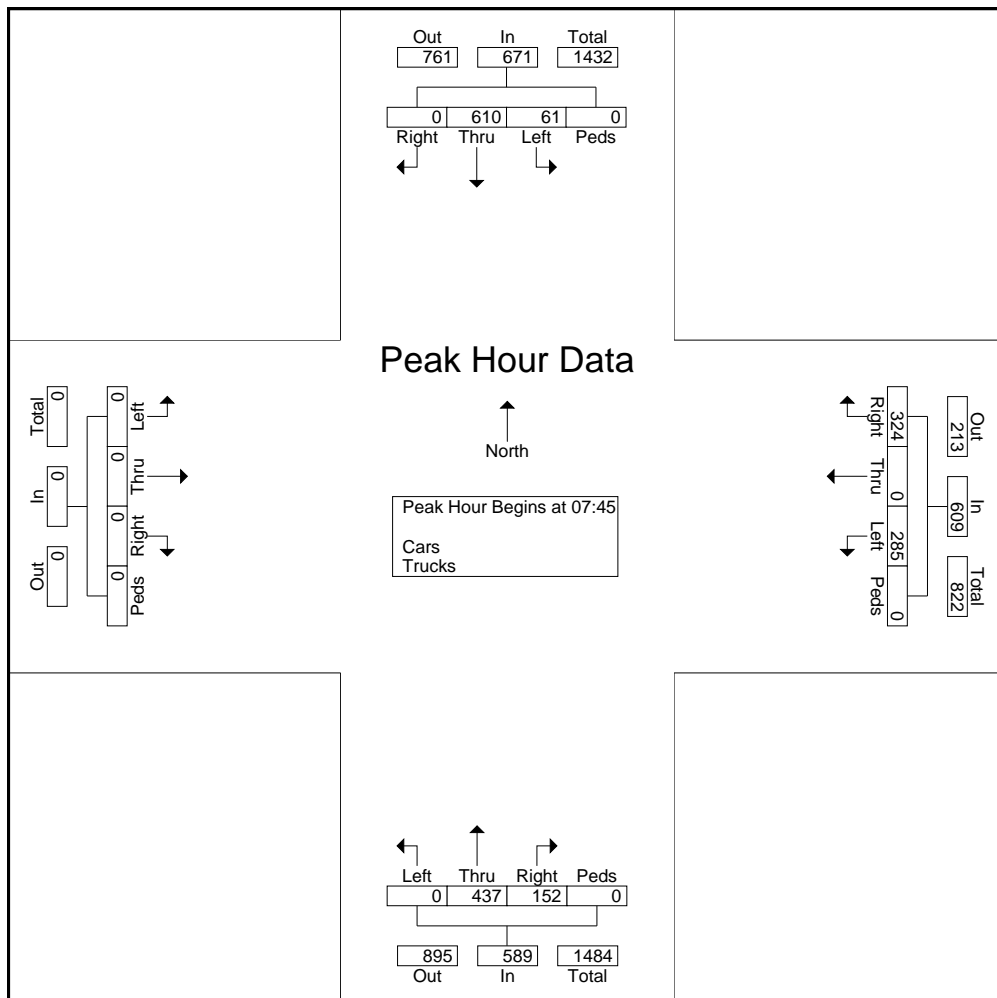

# MINNESOTA DEPARTMENT OF TRANSPORTATION

## TRAFFIC DATA COLLECTION - Metro

Location: Hopkins Xrd and I-394 N Ramp File Name : TMC\_#16 Hopkins Xrd & I-394 N Ramp\_20181002  
 Data Prepared By: ACS Site Code :  
 TURNING MOVEMENT COUNT Start Date : 10/2/2018  
 Page No : 4

Start Time	Southbound					Westbound					Northbound					Eastbound					Int. Total
	Left	Thru	Right	Peds	App. Total	Left	Thru	Right	Peds	App. Total	Left	Thru	Right	Peds	App. Total	Left	Thru	Right	Peds	App. Total	
Peak Hour Analysis From 11:00 to 12:45 - Peak 1 of 1																					
Peak Hour for Entire Intersection Begins at 12:00																					
12:00	29	125	0	0	154	33	0	83	0	116	0	93	32	0	125	0	0	0	0	0	395
12:15	26	121	0	0	147	36	0	62	0	98	0	97	39	0	136	0	0	0	0	0	381
12:30	20	107	0	0	127	27	0	75	0	102	0	90	36	0	126	0	0	0	0	0	355
12:45	25	108	0	0	133	35	0	99	0	134	0	92	42	0	134	0	0	0	0	0	401
Total Volume	100	461	0	0	561	131	0	319	0	450	0	372	149	0	521	0	0	0	0	0	1532
% App. Total	17.8	82.2	0	0		29.1	0	70.9	0		0	71.4	28.6	0		0	0	0	0		
PHF	.862	.922	.000	.000	.911	.910	.000	.806	.000	.840	.000	.959	.887	.000	.958	.000	.000	.000	.000	.000	.955

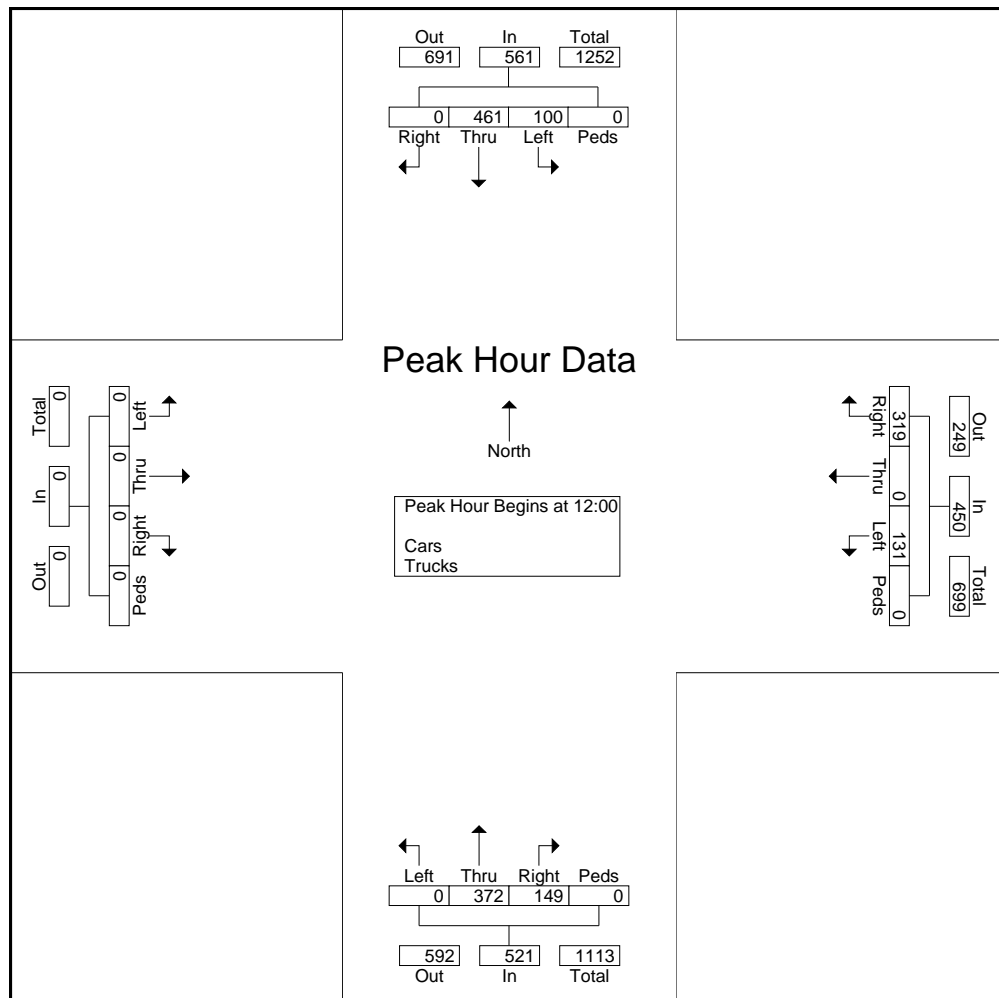

# MINNESOTA DEPARTMENT OF TRANSPORTATION

## TRAFFIC DATA COLLECTION - Metro

Location: Hopkins Xrd and I-394 N Ramp File Name : TMC\_#16 Hopkins Xrd & I-394 N Ramp\_20181002  
 Data Prepared By: ACS Site Code :  
 TURNING MOVEMENT COUNT Start Date : 10/2/2018  
 Page No : 5

Start Time	Southbound					Westbound					Northbound					Eastbound					Int. Total
	Left	Thru	Right	Peds	App. Total	Left	Thru	Right	Peds	App. Total	Left	Thru	Right	Peds	App. Total	Left	Thru	Right	Peds	App. Total	
Peak Hour Analysis From 15:00 to 17:45 - Peak 1 of 1																					
Peak Hour for Entire Intersection Begins at 16:30																					
16:30	20	159	0	0	179	80	0	67	0	147	0	135	42	0	177	0	0	0	0	0	503
16:45	20	151	0	0	171	62	0	58	0	120	0	134	46	0	180	0	0	0	0	0	471
17:00	30	166	0	0	196	74	0	77	0	151	0	142	50	0	192	0	0	0	0	0	539
17:15	39	170	0	0	209	55	0	82	0	137	0	139	54	0	193	0	0	0	0	0	539
Total Volume	109	646	0	0	755	271	0	284	0	555	0	550	192	0	742	0	0	0	0	0	2052
% App. Total	14.4	85.6	0	0		48.8	0	51.2	0		0	74.1	25.9	0		0	0	0	0		
PHF	.699	.950	.000	.000	.903	.847	.000	.866	.000	.919	.000	.968	.889	.000	.961	.000	.000	.000	.000	.000	.952

