



MINNESOTA DEPT OF TRANSPORTATION

TRAFFIC DATA COLLECTION - METRO

I-394 at General Mills Blvd, South Ramps
 REF.PT.: 003.425
 JAMAR # 631 RE
 TURN MOVEMENT COUNT

File Name : I-394 at General Mills Blvd S Ramps 2007
 Site Code : 00000000
 Start Date : 3/28/2007
 Page No : 1

Groups Printed- Cars & Trucks

Start Time	General Mills Blvd Southbound				Loop FROM / Ramp TO I-394 EB Westbound				General Mills Blvd Northbound				Entrance Toyota Dealer Eastbound				Int. Total
	Left	Thru	Right	Peds	Left	Thru	Right	Peds	Left	Thru	Right	Peds	Left	Thru	Right	Peds	
06:00	7	8	0	0	7	1	8	0	0	7	3	0	0	0	0	0	41
06:15	22	11	2	0	10	3	12	0	0	10	7	0	1	0	0	0	78
06:30	17	25	1	0	16	2	20	0	0	18	16	0	0	0	0	0	115
06:45	28	32	4	0	28	9	33	0	0	20	9	0	0	0	0	0	163
Total	74	76	7	0	61	15	73	0	0	55	35	0	1	0	0	0	397
07:00	25	32	1	0	41	9	38	0	0	23	20	0	0	1	0	0	190
07:15	32	48	2	0	45	4	36	0	1	42	27	0	0	0	1	0	238
07:30	21	65	4	0	76	1	70	0	0	53	22	0	0	0	0	0	312
07:45	17	51	3	0	80	4	71	0	0	48	19	0	0	0	0	0	293
Total	95	196	10	0	242	18	215	0	1	166	88	0	0	1	1	0	1033
08:00	15	47	2	0	67	3	82	0	1	43	17	0	0	0	1	0	278
08:15	16	40	4	0	59	6	61	0	0	42	22	0	0	1	3	0	254
08:30	15	40	7	0	32	4	29	0	0	28	25	0	0	1	0	0	181
08:45	16	41	8	0	33	4	24	1	0	30	17	0	4	2	0	0	180
Total	62	168	21	0	191	17	196	1	1	143	81	0	4	4	4	0	893
*** BREAK ***																	
10:45	22	27	6	0	17	6	7	0	6	22	21	0	6	2	5	0	147
Total	22	27	6	0	17	6	7	0	6	22	21	0	6	2	5	0	147
11:00	21	15	3	0	14	6	11	0	4	29	14	0	2	2	4	0	125
11:15	35	27	6	0	25	5	14	0	3	21	17	0	6	1	4	0	164
11:30	40	31	7	0	21	10	11	1	1	27	26	1	5	1	4	0	186
11:45	40	29	8	2	26	10	12	0	1	50	26	0	7	5	2	1	219
Total	136	102	24	2	86	31	48	1	9	127	83	1	20	9	14	1	694
12:00	31	40	3	1	15	9	18	0	2	55	28	0	3	2	2	1	210
12:15	30	29	6	2	19	7	15	0	1	41	17	1	4	2	4	1	179
12:30	23	30	6	1	19	9	25	1	3	46	14	4	7	1	4	0	193
12:45	28	26	5	0	22	3	33	0	1	43	21	1	3	2	1	0	189
Total	112	125	20	4	75	28	91	1	7	185	80	6	17	7	11	2	771
*** BREAK ***																	
14:30	42	26	3	2	33	4	10	0	2	39	20	0	5	2	1	0	189
14:45	21	23	6	0	22	5	11	0	2	37	36	0	3	2	1	0	169
Total	63	49	9	2	55	9	21	0	4	76	56	0	8	4	2	0	358
15:00	47	26	3	0	21	3	16	0	0	53	19	0	5	2	4	0	199
15:15	30	38	9	0	31	6	19	0	1	62	31	0	2	2	2	0	233
15:30	48	29	4	0	38	2	26	0	0	43	9	0	3	4	1	0	207
15:45	52	47	4	0	34	5	26	0	1	49	18	0	5	4	4	0	249
Total	177	140	20	0	124	16	87	0	2	207	77	0	15	12	11	0	888
16:00	63	44	6	0	26	3	36	0	3	63	20	0	4	1	1	0	270
16:15	63	58	6	1	17	2	37	2	2	42	17	0	4	1	3	0	255
16:30	66	59	4	2	29	3	38	0	2	67	22	0	2	1	6	0	301
16:45	67	61	4	0	37	5	38	0	1	66	16	0	7	1	2	0	305
Total	259	222	20	3	109	13	149	2	8	238	75	0	17	4	12	0	1131



MINNESOTA DEPT OF TRANSPORTATION

TRAFFIC DATA COLLECTION - METRO

I-394 at General Mills Blvd, South Ramps
 REF.PT.: 003.425
 JAMAR # 631 RE
 TURN MOVEMENT COUNT

File Name : I-394 at General Mills Blvd S Ramps 2007
 Site Code : 00000000
 Start Date : 3/28/2007
 Page No : 2

Groups Printed- Cars & Trucks

Start Time	General Mills Blvd Southbound				Loop FROM / Ramp TO I-394 EB Westbound				General Mills Blvd Northbound				Entrance Toyota Dealer Eastbound				Int. Total
	Left	Thru	Right	Peds	Left	Thru	Right	Peds	Left	Thru	Right	Peds	Left	Thru	Right	Peds	
17:00	61	82	4	0	21	4	38	0	0	96	24	1	5	6	2	0	344
17:15	52	75	6	0	29	3	47	0	3	72	19	0	4	1	0	0	311
17:30	58	57	4	0	30	3	43	0	2	60	12	0	4	1	2	0	276
17:45	62	45	2	0	35	2	37	0	1	48	14	0	5	2	0	0	253
Total	233	259	16	0	115	12	165	0	6	276	69	1	18	10	4	0	1184
Grand Total	1233	1364	153	11	1075	165	1052	5	44	1495	665	8	106	53	64	3	7496
Apprch %	44.7	49.4	5.5	0.4	46.8	7.2	45.8	0.2	2	67.6	30.1	0.4	46.9	23.5	28.3	1.3	
Total %	16.4	18.2	2	0.1	14.3	2.2	14	0.1	0.6	19.9	8.9	0.1	1.4	0.7	0.9	0	



MINNESOTA DEPT OF TRANSPORTATION

TRAFFIC DATA COLLECTION - METRO

I-394 at General Mills Blvd, South Ramps
 REF.PT.: 003.425
 JAMAR # 631 RE
 TURN MOVEMENT COUNT

File Name : I-394 at General Mills Blvd S Ramps 2007
 Site Code : 00000000
 Start Date : 3/28/2007
 Page No : 3

Start Time	General Mills Blvd Southbound					Loop FROM / Ramp TO I-394 EB Westbound					General Mills Blvd Northbound					Entrance Toyota Dealer Eastbound					Int. Total
	Left	Thru	Right	Peds	App. Total	Left	Thru	Right	Peds	App. Total	Left	Thru	Right	Peds	App. Total	Left	Thru	Right	Peds	App. Total	
Peak Hour Analysis From 06:00 to 08:45 - Peak 1 of 1																					
Peak Hour for Entire Intersection Begins at 07:30																					
07:30	21	65	4	0	90	76	1	70	0	147	0	53	22	0	75	0	0	0	0	0	312
07:45	17	51	3	0	71	80	4	71	0	155	0	48	19	0	67	0	0	0	0	0	293
08:00	15	47	2	0	64	67	3	82	0	152	1	43	17	0	61	0	0	1	0	1	278
08:15	16	40	4	0	60	59	6	61	0	126	0	42	22	0	64	0	1	3	0	4	254
Total Volume	69	203	13	0	285	282	14	284	0	580	1	186	80	0	267	0	1	4	0	5	1137
% App. Total																					
PHF	.821	.781	.813	.000	.792	.881	.583	.866	.000	.935	.250	.877	.909	.000	.890	.000	.250	.333	.000	.313	.911

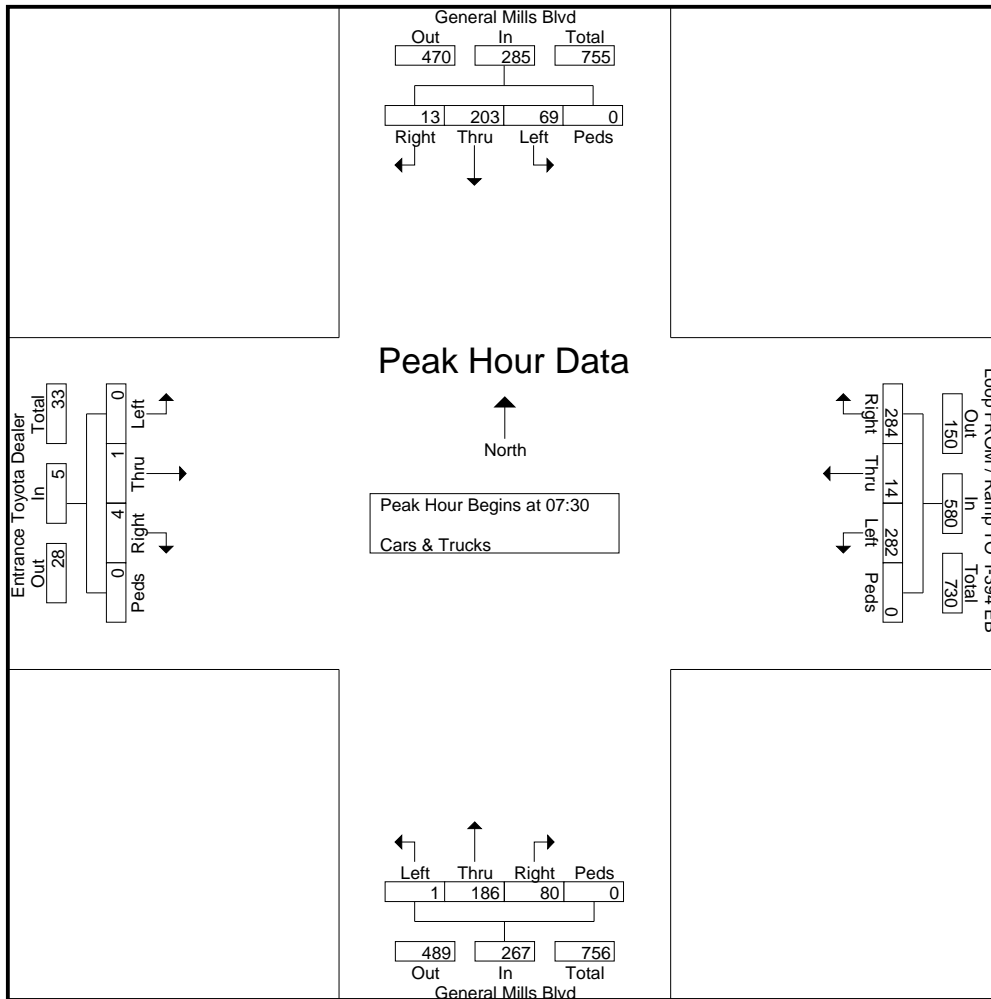



MINNESOTA DEPT OF TRANSPORTATION

TRAFFIC DATA COLLECTION - METRO

I-394 at General Mills Blvd, South Ramps
 REF.PT.: 003.425
 JAMAR # 631 RE
 TURN MOVEMENT COUNT

File Name : I-394 at General Mills Blvd S Ramps 2007
 Site Code : 00000000
 Start Date : 3/28/2007
 Page No : 4

Start Time	General Mills Blvd Southbound					Loop FROM / Ramp TO I-394 EB Westbound					General Mills Blvd Northbound					Entrance Toyota Dealer Eastbound					Int. Total
	Left	Thru	Right	Peds	App. Total	Left	Thru	Right	Peds	App. Total	Left	Thru	Right	Peds	App. Total	Left	Thru	Right	Peds	App. Total	
Peak Hour Analysis From 15:00 to 17:45 - Peak 1 of 1																					
Peak Hour for Entire Intersection Begins at 16:30																					
16:30	66	59	4	2	131	29	3	38	0	70	2	67	22	0	91	2	1	6	0	9	301
16:45	67	61	4	0	132	37	5	38	0	80	1	66	16	0	83	7	1	2	0	10	305
17:00	61	82	4	0	147	21	4	38	0	63	0	96	24	1	121	5	6	2	0	13	344
17:15	52	75	6	0	133	29	3	47	0	79	3	72	19	0	94	4	1	0	0	5	311
Total Volume	246	277	18	2	543	116	15	161	0	292	6	301	81	1	389	18	9	10	0	37	1261
% App. Total																					
PHF	.918	.845	.750	.250	.923	.784	.750	.856	.000	.913	.500	.784	.844	.250	.804	.643	.375	.417	.000	.712	.916

