



MINNESOTA DEPT OF TRANSPORTATION

TRAFFIC DATA COLLECTION - METRO

I-394 AT LOUISIANA AVE., S RAMPS File Name : I-394 AT LOUISIANA AVE-S RAMPS AMPM 2007
 REF.PT.: 004.455 Site Code : 00000000
 JAMAR # 631 /632 RE/DR Start Date : 4/25/2007
 TURN MOVEMENT COUNT Page No : 1

Groups Printed- Cars & Trucks

Start Time	LOUISIANA AVE Southbound				RAMP TO I-394 EB Westbound				LOUISIANA AVE Northbound				RAMP FROM I-394 EB Eastbound				Int. Total
	Left	Thru	Right	Peds	Left	Thru	Right	Peds	Left	Thru	Right	Peds	Left	Thru	Right	Peds	
06:00	6	38	0	0	0	0	0	0	0	29	32	0	12	1	29	0	147
06:15	6	35	0	0	0	0	0	0	0	37	50	0	29	0	33	0	190
06:30	10	30	0	0	0	0	0	0	0	47	76	1	29	1	38	0	232
06:45	10	67	0	0	0	0	0	0	0	73	68	0	33	0	81	0	332
Total	32	170	0	0	0	0	0	0	0	186	226	1	103	2	181	0	901
07:00	23	56	0	1	0	0	0	0	0	70	77	0	49	1	58	0	335
07:15	21	91	0	0	0	0	0	0	0	108	109	1	37	1	71	0	439
07:30	20	89	0	0	0	0	0	0	0	127	132	0	35	3	63	0	469
07:45	17	91	0	1	0	0	0	0	0	177	152	0	43	3	53	0	537
Total	81	327	0	2	0	0	0	0	0	482	470	1	164	8	245	0	1780
08:00	24	100	0	0	0	0	0	0	0	138	137	0	70	6	86	0	561
08:15	22	90	0	0	0	0	0	0	0	115	117	0	71	4	61	0	480
08:30	33	84	0	0	0	0	0	0	0	100	111	0	71	4	86	0	489
08:45	27	91	0	0	0	0	0	0	0	97	116	0	69	18	81	0	499
Total	106	365	0	0	0	0	0	0	0	450	481	0	281	32	314	0	2029
*** BREAK ***																	
14:45	47	120	0	1	0	0	0	0	0	106	73	1	65	0	74	0	487
Total	47	120	0	1	0	0	0	0	0	106	73	1	65	0	74	0	487
15:00	57	124	0	1	0	0	0	0	0	141	75	1	63	2	66	0	530
15:15	43	109	0	0	0	0	0	0	0	113	82	0	49	0	70	0	466
15:30	42	84	0	0	0	0	0	0	0	128	98	0	68	2	44	0	466
15:45	38	131	0	0	0	0	0	0	0	116	79	0	34	2	84	0	484
Total	180	448	0	1	0	0	0	0	0	498	334	1	214	6	264	0	1946
16:00	36	133	0	0	0	0	0	0	0	174	70	0	47	2	67	0	529
16:15	37	121	0	0	0	0	0	0	0	166	61	0	63	1	85	0	534
16:30	38	138	0	1	0	0	0	0	0	177	77	0	32	3	104	0	570
16:45	30	132	0	0	0	0	0	0	0	173	79	1	65	3	90	0	573
Total	141	524	0	1	0	0	0	0	0	690	287	1	207	9	346	0	2206
17:00	25	153	0	0	0	0	0	0	0	184	85	0	56	5	91	0	599
17:15	31	173	0	0	0	0	0	0	0	249	79	0	63	3	87	0	685
17:30	36	154	0	0	0	0	0	0	0	164	103	1	49	1	97	0	605
17:45	39	155	0	1	0	0	0	0	0	168	95	0	66	2	95	0	621
Total	131	635	0	1	0	0	0	0	0	765	362	1	234	11	370	0	2510
Grand Total	718	2589	0	6	0	0	0	0	0	3177	2233	6	1268	68	1794	0	11859
Aprch %	21.7	78.1	0	0.2	0	0	0	0	0	58.7	41.2	0.1	40.5	2.2	57.3	0	
Total %	6.1	21.8	0	0.1	0	0	0	0	0	26.8	18.8	0.1	10.7	0.6	15.1	0	



MINNESOTA DEPT OF TRANSPORTATION

TRAFFIC DATA COLLECTION - METRO

I-394 AT LOUISIANA AVE., S RAMPS File Name : I-394 AT LOUISIANA AVE-S RAMPS AMPM 2007
 REF.PT.: 004.455 Site Code : 00000000
 JAMAR # 631 /632 RE/DR Start Date : 4/25/2007
 TURN MOVEMENT COUNT Page No : 2

Start Time	LOUISIANA AVE Southbound					RAMP TO I-394 EB Westbound					LOUISIANA AVE Northbound					RAMP FROM I-394 EB Eastbound					Int. Total
	Left	Thru	Right	Peds	App. Total	Left	Thru	Right	Peds	App. Total	Left	Thru	Right	Peds	App. Total	Left	Thru	Right	Peds	App. Total	
Peak Hour Analysis From 06:00 to 08:45 - Peak 1 of 1																					
Peak Hour for Entire Intersection Begins at 07:45																					
07:45	17	91	0	1	109	0	0	0	0	0	0	177	152	0	329	43	3	53	0	99	537
08:00	24	100	0	0	124	0	0	0	0	0	0	138	137	0	275	70	6	86	0	162	561
08:15	22	90	0	0	112	0	0	0	0	0	0	115	117	0	232	71	4	61	0	136	480
08:30	33	84	0	0	117	0	0	0	0	0	0	100	111	0	211	71	4	86	0	161	489
Total Volume	96	365	0	1	462	0	0	0	0	0	0	530	517	0	1047	255	17	286	0	558	2067
% App. Total																					
PHF	.727	.913	.000	.250	.931	.000	.000	.000	.000	.000	.000	.749	.850	.000	.796	.898	.708	.831	.000	.861	.921

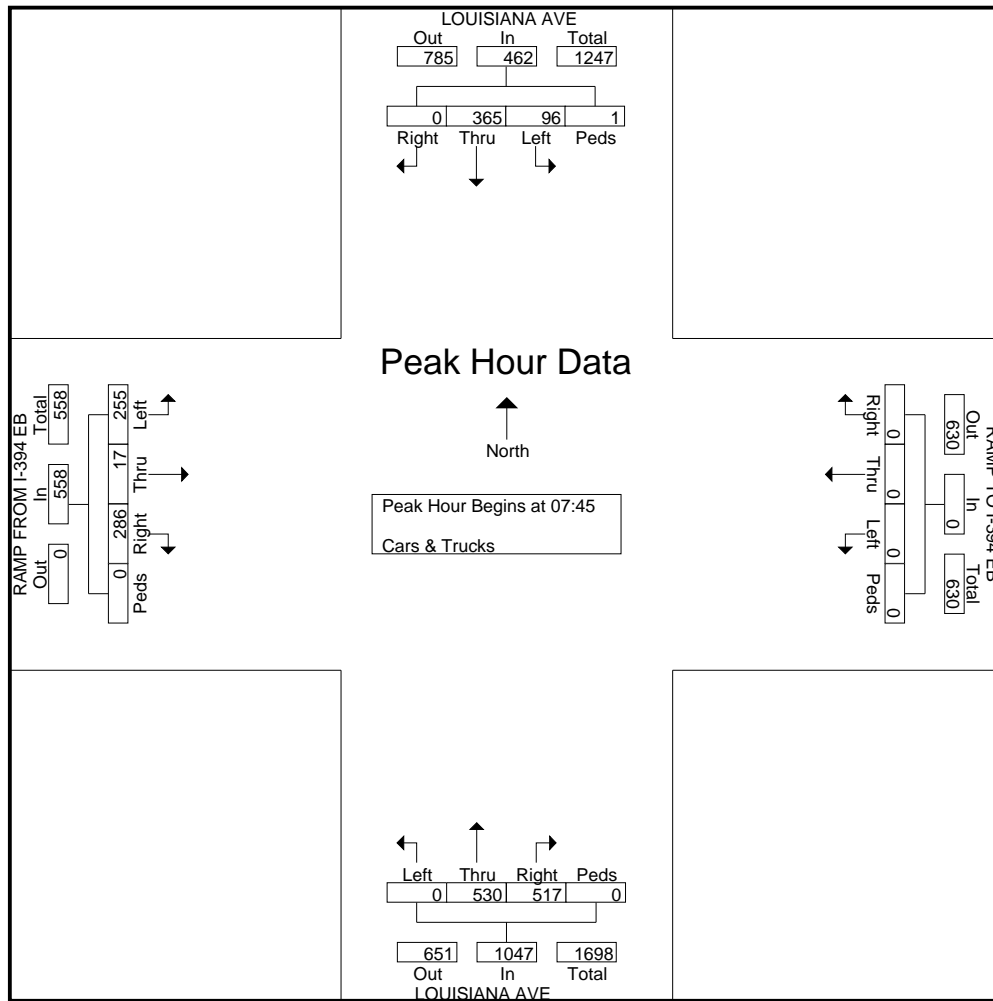



MINNESOTA DEPT OF TRANSPORTATION

TRAFFIC DATA COLLECTION - METRO

I-394 AT LOUISIANA AVE., S RAMPS File Name : I-394 AT LOUISIANA AVE-S RAMPS AMPM 2007
 REF.PT.: 004.455 Site Code : 00000000
 JAMAR # 631 /632 RE/DR Start Date : 4/25/2007
 TURN MOVEMENT COUNT Page No : 3

Start Time	LOUISIANA AVE Southbound					RAMP TO I-394 EB Westbound					LOUISIANA AVE Northbound					RAMP FROM I-394 EB Eastbound					Int. Total
	Left	Thru	Right	Peds	App. Total	Left	Thru	Right	Peds	App. Total	Left	Thru	Right	Peds	App. Total	Left	Thru	Right	Peds	App. Total	
Peak Hour Analysis From 15:00 to 17:45 - Peak 1 of 1																					
Peak Hour for Entire Intersection Begins at 17:00																					
17:00	25	153	0	0	178	0	0	0	0	0	0	184	85	0	269	56	5	91	0	152	599
17:15	31	173	0	0	204	0	0	0	0	0	0	249	79	0	328	63	3	87	0	153	685
17:30	36	154	0	0	190	0	0	0	0	0	0	164	103	1	268	49	1	97	0	147	605
17:45	39	155	0	1	195	0	0	0	0	0	0	168	95	0	263	66	2	95	0	163	621
Total Volume	131	635	0	1	767	0	0	0	0	0	0	765	362	1	1128	234	11	370	0	615	2510
% App. Total																					
PHF	.840	.918	.000	.250	.940	.000	.000	.000	.000	.000	.000	.768	.879	.250	.860	.886	.550	.954	.000	.943	.916

