

# Albeck Gerken, Inc

Transportation Engineers

Traffic Data Collection

I-494 at Lake Rd, west ramps  
Woodbury, MN  
Ref.Pt.: 060.720  
TURN MOVEMENT COUNT

File Name : 19 I-494 West Ramp at Lake Rd  
Site Code : 19  
Start Date : 4/10/2012  
Page No : 1

Groups Printed- Cars - Heavy Vehicles

Start Time	Woodwinds Drive Southbound				Lake Rd Westbound				loop from / ramp to I-494 SB Northbound				Lake Rd Eastbound				Int. Total
	Left	Thru	Right	Peds	Left	Thru	Right	Peds	Left	Thru	Right	Peds	Left	Thru	Right	Peds	
06:00	0	2	0	0	50	35	17	0	1	6	4	0	4	17	30	0	166
06:15	3	1	9	0	62	72	29	0	1	10	14	0	1	30	35	0	267
06:30	2	2	1	0	96	95	34	0	4	7	12	0	2	22	56	0	333
06:45	7	4	4	0	92	106	75	0	4	13	21	0	9	39	34	0	408
Total	12	9	14	0	300	308	155	0	10	36	51	0	16	108	155	0	1174
07:00	7	9	0	0	87	109	37	0	4	12	23	0	3	49	41	0	381
07:15	17	9	6	0	126	124	52	3	15	8	34	0	5	60	55	0	514
07:30	12	18	3	0	136	145	73	0	22	14	25	0	5	38	41	0	532
07:45	22	12	4	0	106	139	74	0	11	12	29	0	13	59	39	0	520
Total	58	48	13	0	455	517	236	3	52	46	111	0	26	206	176	0	1947
08:00	17	11	2	0	77	113	54	0	12	17	32	0	10	41	40	0	426
08:15	15	17	10	0	84	96	69	0	19	12	24	0	5	39	35	0	425
08:30	18	17	4	0	81	65	58	0	7	12	23	0	1	34	33	1	354
08:45	13	8	1	0	64	59	28	0	15	13	10	0	10	42	35	0	298
Total	63	53	17	0	306	333	209	0	53	54	89	0	26	156	143	1	1503
09:00	20	20	1	0	63	61	23	0	15	9	24	0	5	44	19	0	304
09:15	17	18	5	0	52	44	30	0	16	15	21	0	6	35	19	0	278
09:30	17	19	4	0	39	35	25	0	9	12	30	0	8	31	21	0	250
09:45	13	12	9	0	49	46	35	0	11	11	24	0	8	33	23	0	274
Total	67	69	19	0	203	186	113	0	51	47	99	0	27	143	82	0	1106
10:00	27	14	11	0	34	40	31	0	16	11	20	0	14	28	35	0	281
10:15	20	20	10	0	24	29	30	0	15	13	22	0	10	26	25	0	244
10:30	23	18	11	0	38	48	38	0	8	17	22	0	7	33	20	0	283
10:45	23	16	7	0	33	39	44	0	6	7	33	0	13	33	23	0	277
Total	93	68	39	0	129	156	143	0	45	48	97	0	44	120	103	0	1085
11:00	28	24	6	0	29	41	44	0	8	5	26	0	7	44	19	0	281
11:15	19	15	11	0	35	43	35	0	12	9	15	0	10	47	15	0	266
11:30	29	20	12	0	35	37	29	0	12	8	19	0	8	43	14	0	266
11:45	28	20	10	0	34	42	30	0	9	8	28	0	3	46	22	0	280
Total	104	79	39	0	133	163	138	0	41	30	88	0	28	180	70	0	1093
12:00	27	15	10	0	31	46	33	0	12	3	28	0	1	50	14	0	270
12:15	26	17	14	0	31	32	35	0	13	8	21	0	9	53	16	0	275
12:30	25	15	10	0	26	46	32	0	9	10	26	0	6	36	13	0	254
12:45	32	18	12	1	35	52	50	0	12	11	25	0	11	38	18	0	315
Total	110	65	46	1	123	176	150	0	46	32	100	0	27	177	61	0	1114
13:00	31	17	17	0	51	46	30	0	14	8	32	0	7	30	16	0	299
13:15	25	20	9	0	31	24	38	0	17	15	27	0	5	40	19	0	270
13:30	18	23	10	0	21	33	44	0	13	7	27	0	7	35	17	0	255
13:45	21	22	15	0	33	46	36	0	14	11	29	0	12	53	18	0	310
Total	95	82	51	0	136	149	148	0	58	41	115	0	31	158	70	0	1134
14:00	30	20	10	0	41	41	29	0	5	13	31	0	5	40	21	0	286
14:15	25	30	6	0	36	51	45	0	11	11	50	0	5	51	16	0	337
14:30	28	23	6	0	36	54	29	0	9	12	40	0	9	46	28	0	320
14:45	34	25	15	0	53	59	34	1	21	14	34	0	13	44	24	0	371
Total	117	98	37	0	166	205	137	1	46	50	155	0	32	181	89	0	1314
15:00	26	17	11	0	55	51	30	0	15	6	41	0	15	58	41	0	366
15:15	25	19	13	0	46	59	31	0	15	10	55	0	5	55	25	0	358
15:30	32	28	9	0	70	67	28	0	11	6	49	0	7	64	30	0	401
15:45	37	26	10	0	56	57	43	0	17	9	44	0	6	72	33	0	410
Total	120	90	43	0	227	234	132	0	58	31	189	0	33	249	129	0	1535

# Albeck Gerken, Inc

Transportation Engineers

Traffic Data Collection

I-494 at Lake Rd, west ramps  
Woodbury, MN  
Ref.Pt.: 060.720  
TURN MOVEMENT COUNT

File Name : 19 I-494 West Ramp at Lake Rd  
Site Code : 19  
Start Date : 4/10/2012  
Page No : 2

## Groups Printed- Cars - Heavy Vehicles

Start Time	Woodwinds Drive Southbound				Lake Rd Westbound				loop from / ramp to I-494 SB Northbound				Lake Rd Eastbound				Int. Total
	Left	Thru	Right	Peds	Left	Thru	Right	Peds	Left	Thru	Right	Peds	Left	Thru	Right	Peds	
16:00	39	23	14	0	54	75	26	0	25	6	52	0	3	68	34	0	419
16:15	30	40	4	0	74	64	30	0	20	5	67	0	5	81	34	0	454
16:30	51	35	14	0	71	69	18	0	12	3	64	0	5	92	46	0	480
16:45	34	24	14	0	49	71	29	0	26	3	63	0	13	105	40	0	471
Total	154	122	46	0	248	279	103	0	83	17	246	0	26	346	154	0	1824
17:00	49	38	8	0	74	66	23	0	30	5	76	0	6	119	40	0	534
17:15	36	16	20	0	61	69	34	0	19	5	73	0	13	92	33	0	471
17:30	32	25	14	0	58	68	24	0	20	2	71	0	6	80	30	0	430
17:45	24	18	12	1	41	55	38	0	17	2	84	0	13	62	24	1	392
Total	141	97	54	1	234	258	119	0	86	14	304	0	38	353	127	1	1827
18:00	34	11	11	0	45	46	29	0	14	6	62	0	8	70	27	0	363
18:15	20	9	9	0	35	43	17	0	21	13	62	0	14	69	10	0	322
18:30	22	12	14	0	36	55	14	0	15	5	56	1	3	66	22	0	321
18:45	11	8	11	0	42	37	22	0	19	2	61	0	7	43	22	0	285
Total	87	40	45	0	158	181	82	0	69	26	241	1	32	248	81	0	1291
Grand Total	1221	920	463	2	2818	3145	1865	4	698	472	1885	1	386	2625	1440	2	17947
Apprch %	46.9	35.3	17.8	0.1	36	40.2	23.8	0.1	22.8	15.4	61.7	0	8.7	58.9	32.3	0	
Total %	6.8	5.1	2.6	0	15.7	17.5	10.4	0	3.9	2.6	10.5	0	2.2	14.6	8	0	
Cars	1195	903	451	2	2686	3079	1828	4	678	460	1797	1	384	2564	1410	2	17444
% Cars	97.9	98.2	97.4	100	95.3	97.9	98	100	97.1	97.5	95.3	100	99.5	97.7	97.9	100	97.2
Heavy Vehicles	26	17	12	0	132	66	37	0	20	12	88	0	2	61	30	0	503
% Heavy Vehicles	2.1	1.8	2.6	0	4.7	2.1	2	0	2.9	2.5	4.7	0	0.5	2.3	2.1	0	2.8

# Albeck Gerken, Inc

Transportation Engineers

Traffic Data Collection

I-494 at Lake Rd, west ramps  
Woodbury, MN  
Ref.Pt.: 060.720  
TURN MOVEMENT COUNT

File Name : 19 I-494 West Ramp at Lake Rd  
Site Code : 19  
Start Date : 4/10/2012  
Page No : 3

Start Time	Woodwinds Drive Southbound					Lake Rd Westbound					loop from / ramp to I-494 SB Northbound					Lake Rd Eastbound					Int. Total
	Left	Thru	Right	Peds	App. Total	Left	Thru	Right	Peds	App. Total	Left	Thru	Right	Peds	App. Total	Left	Thru	Right	Peds	App. Total	
Peak Hour Analysis From 06:00 to 09:00 - Peak 1 of 1																					
Peak Hour for Entire Intersection Begins at 07:15																					
07:15	17	9	6	0	32	126	124	52	3	305	15	8	34	0	57	5	60	55	0	120	514
07:30	12	18	3	0	33	136	145	73	0	354	22	14	25	0	61	5	38	41	0	84	532
07:45	22	12	4	0	38	106	139	74	0	319	11	12	29	0	52	13	59	39	0	111	520
08:00	17	11	2	0	30	77	113	54	0	244	12	17	32	0	61	10	41	40	0	91	426
Total Volume	68	50	15	0	133	445	521	253	3	1222	60	51	120	0	231	33	198	175	0	406	1992
% App. Total	51.1	37.6	11.3	0		36.4	42.6	20.7	0.2		26	22.1	51.9	0		8.1	48.8	43.1	0		
PHF	.773	.694	.625	.000	.875	.818	.898	.855	.250	.863	.682	.750	.882	.000	.947	.635	.825	.795	.000	.846	.936

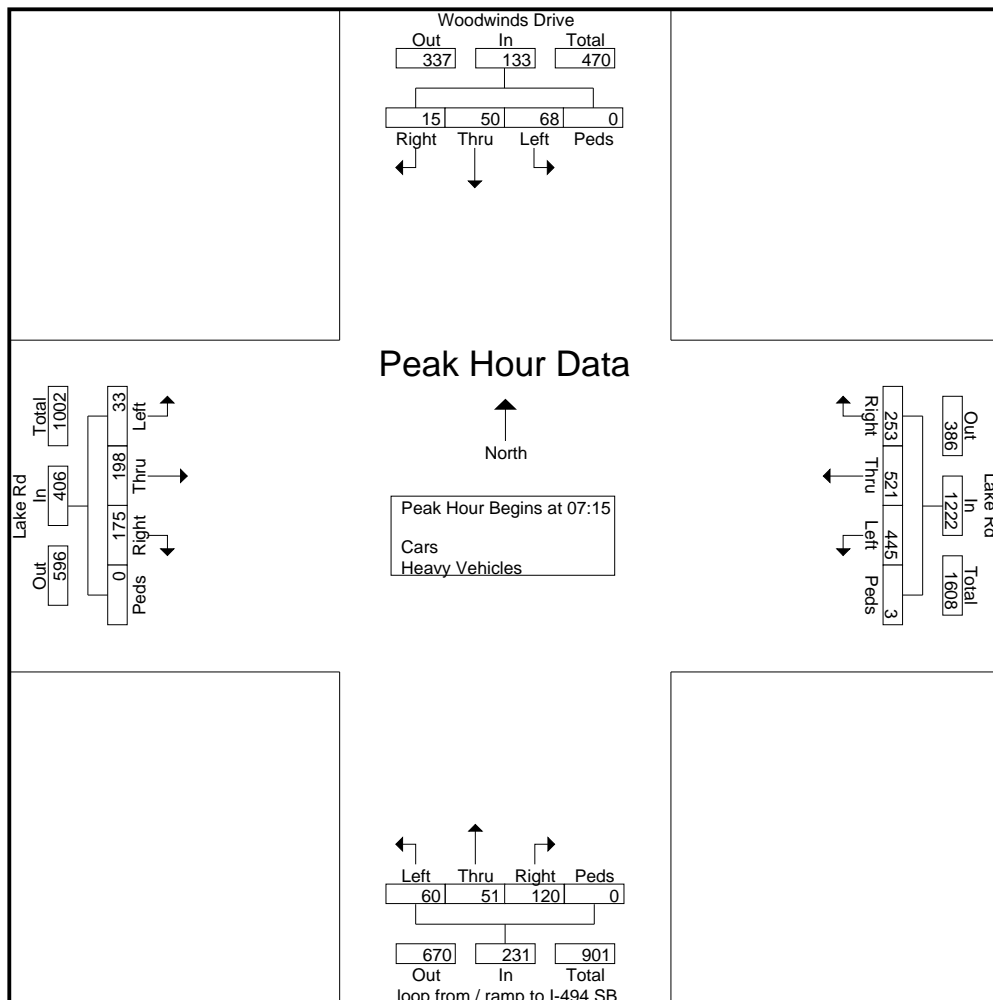

# Albeck Gerken, Inc

Transportation Engineers

Traffic Data Collection

I-494 at Lake Rd, west ramps  
Woodbury, MN  
Ref.Pt.: 060.720  
TURN MOVEMENT COUNT

File Name : 19 I-494 West Ramp at Lake Rd  
Site Code : 19  
Start Date : 4/10/2012  
Page No : 4

Start Time	Woodwinds Drive Southbound					Lake Rd Westbound					loop from / ramp to I-494 SB Northbound					Lake Rd Eastbound					Int. Total
	Left	Thru	Right	Peds	App. Total	Left	Thru	Right	Peds	App. Total	Left	Thru	Right	Peds	App. Total	Left	Thru	Right	Peds	App. Total	
Peak Hour Analysis From 15:00 to 18:45 - Peak 1 of 1																					
Peak Hour for Entire Intersection Begins at 16:30																					
16:30	51	35	14	0	100	71	69	18	0	158	12	3	64	0	79	5	92	46	0	143	480
16:45	34	24	14	0	72	49	71	29	0	149	26	3	63	0	92	13	105	40	0	158	471
17:00	49	38	8	0	95	74	66	23	0	163	30	5	76	0	111	6	119	40	0	165	534
17:15	36	16	20	0	72	61	69	34	0	164	19	5	73	0	97	13	92	33	0	138	471
Total Volume	170	113	56	0	339	255	275	104	0	634	87	16	276	0	379	37	408	159	0	604	1956
% App. Total	50.1	33.3	16.5	0		40.2	43.4	16.4	0		23	4.2	72.8	0		6.1	67.5	26.3	0		
PHF	.833	.743	.700	.000	.848	.861	.968	.765	.000	.966	.725	.800	.908	.000	.854	.712	.857	.864	.000	.915	.916

