

Alliant Engineering

Minneapolis, MN 55415

--TRAFFIC DATA --

Hanson Blvd at Northdale Blvd

Ref.Pt.:

Alliant Eng.

TURN MOVEMENT COUNT

File Name : 223_Hanson Blvd & Northdale Blvd

Site Code : 223

Start Date : 3/1/2016

Page No : 1

Groups Printed- Vehicles - Trucks

Start Time	Hanson Blvd Southbound				Northdale Blvd Westbound				Hanson Blvd Northbound				Northdale Blvd Eastbound				Int. Total
	Left	Thru	Rght	Other	Left	Thru	Rght	Other	Left	Thru	Rght	Other	Left	Thru	Rght	Other	
06:00	4	302	9	0	17	12	7	0	10	44	24	0	3	3	27	0	462
06:15	6	367	13	0	22	5	1	0	18	53	49	0	4	14	28	0	580
06:30	2	498	21	0	20	16	1	0	14	64	63	0	6	11	15	0	731
06:45	7	442	24	0	21	21	1	0	18	93	88	0	8	11	33	0	767
Total	19	1609	67	0	80	54	10	0	60	254	224	0	21	39	103	0	2540
07:00	0	475	25	0	35	18	2	0	17	119	43	0	10	16	34	0	794
07:15	7	547	14	0	68	24	2	0	6	113	55	0	9	15	49	0	909
07:30	6	503	23	1	56	22	1	0	27	130	74	0	8	8	36	0	895
07:45	12	418	15	0	43	19	2	0	29	135	74	0	20	23	39	0	829
Total	25	1943	77	1	202	83	7	0	79	497	246	0	47	62	158	0	3427
08:00	5	374	15	0	26	15	7	0	16	120	48	0	7	18	25	0	676
08:15	13	314	17	0	33	11	11	0	21	103	40	0	7	7	33	0	610
08:30	14	334	13	0	36	9	6	0	12	120	56	0	14	8	31	0	653
08:45	21	333	8	0	43	12	7	0	30	138	63	0	8	9	25	0	697
Total	53	1355	53	0	138	47	31	0	79	481	207	0	36	42	114	0	2636
09:00	6	290	9	0	47	18	2	0	21	115	60	0	17	16	24	0	625
09:15	3	262	13	0	49	11	9	0	21	150	46	0	15	4	23	0	606
*** BREAK ***																	
Total	9	552	22	0	96	29	11	0	42	265	106	0	32	20	47	0	1231
*** BREAK ***																	
10:30	10	113	6	0	49	11	10	0	28	115	51	0	13	11	23	0	440
10:45	12	111	6	0	62	5	15	0	21	153	36	0	9	13	19	0	462
Total	22	224	12	0	111	16	25	0	49	268	87	0	22	24	42	0	902
11:00	4	105	5	0	64	8	8	0	32	212	43	0	14	8	10	0	513
11:15	12	102	5	0	57	12	14	0	20	187	51	0	16	15	15	0	506
11:30	14	109	4	0	67	23	9	0	31	200	48	0	14	16	22	0	557
11:45	7	85	6	0	62	12	12	0	32	164	68	0	20	12	8	0	488
Total	37	401	20	0	250	55	43	0	115	763	210	0	64	51	55	0	2064
12:00	17	104	5	1	53	30	6	0	36	156	58	0	26	31	16	0	539
12:15	8	121	12	0	80	22	12	0	27	184	40	0	20	22	21	0	569
12:30	10	136	14	0	59	7	11	0	42	179	59	0	25	7	18	0	567
12:45	7	126	10	0	43	13	19	0	28	192	41	0	18	12	26	0	535
Total	42	487	41	1	235	72	48	0	133	711	198	0	89	72	81	0	2210
13:00	15	123	5	0	49	8	18	0	37	144	75	0	13	14	11	0	512
13:15	13	177	8	0	60	6	13	0	16	138	65	0	12	13	19	0	540
*** BREAK ***																	
Total	28	300	13	0	109	14	31	0	53	282	140	0	25	27	30	0	1052
*** BREAK ***																	
14:30	17	159	15	0	87	8	17	0	50	235	57	0	17	11	17	0	690
14:45	13	137	11	0	65	5	23	0	43	262	44	0	31	13	16	0	663
Total	30	296	26	0	152	13	40	0	93	497	101	0	48	24	33	0	1353
15:00	9	145	11	0	86	13	17	0	48	250	52	0	30	13	14	0	688
15:15	15	164	9	0	72	22	21	0	46	267	66	0	27	11	18	0	738
15:30	15	164	9	0	87	10	15	0	31	293	47	0	17	12	16	0	716
15:45	7	174	15	0	82	7	23	0	37	330	57	0	30	12	3	0	777
Total	46	647	44	0	327	52	76	0	162	1140	222	0	104	48	51	0	2919
16:00	18	168	6	0	94	19	26	0	33	376	64	0	27	14	8	0	853
16:15	23	179	6	0	68	7	18	0	24	331	48	0	37	16	12	0	769
16:30	13	184	2	0	116	10	36	0	19	316	49	0	28	11	7	0	791

Alliant Engineering

Minneapolis, MN 55415

--TRAFFIC DATA --

Hanson Blvd at Northdale Blvd

Ref.Pt.:

Alliant Eng.

TURN MOVEMENT COUNT

File Name : 223_Hanson Blvd & Northdale Blvd

Site Code : 223

Start Date : 3/1/2016

Page No : 2

Groups Printed- Vehicles - Trucks

Start Time	Hanson Blvd Southbound				Northdale Blvd Westbound				Hanson Blvd Northbound				Northdale Blvd Eastbound				Int. Total
	Left	Thru	Rght	Other	Left	Thru	Rght	Other	Left	Thru	Rght	Other	Left	Thru	Rght	Other	
16:45	20	193	5	0	71	12	27	0	37	297	67	0	27	9	14	0	779
Total	74	724	19	0	349	48	107	0	113	1320	228	0	119	50	41	0	3192
17:00	8	133	7	0	53	17	29	0	34	479	64	0	25	22	9	0	880
17:15	10	151	8	0	40	16	12	0	24	299	66	0	30	24	2	0	682
17:30	19	158	3	0	70	14	25	0	46	289	34	0	27	8	6	0	699
17:45	25	162	4	0	67	16	40	0	54	271	72	0	33	9	10	0	763
Total	62	604	22	0	230	63	106	0	158	1338	236	0	115	63	27	0	3024
Grand Total	447	9142	416	2	2279	546	535	0	1136	7816	2205	0	722	522	782	0	26550
Apprch %	4.5	91.4	4.2	0	67.8	16.2	15.9	0	10.2	70.1	19.8	0	35.6	25.8	38.6	0	
Total %	1.7	34.4	1.6	0	8.6	2.1	2	0	4.3	29.4	8.3	0	2.7	2	2.9	0	
Vehicles	429	8939	407	2	2059	528	515	0	1118	7542	1975	0	711	508	775	0	25508
% Vehicles	96	97.8	97.8	100	90.3	96.7	96.3	0	98.4	96.5	89.6	0	98.5	97.3	99.1	0	96.1
Trucks	18	203	9	0	220	18	20	0	18	274	230	0	11	14	7	0	1042
% Trucks	4	2.2	2.2	0	9.7	3.3	3.7	0	1.6	3.5	10.4	0	1.5	2.7	0.9	0	3.9

Alliant Engineering

Minneapolis, MN 55415

--TRAFFIC DATA --

Hanson Blvd at Northdale Blvd

Ref.Pt.:

Alliant Eng.

TURN MOVEMENT COUNT

File Name : 223_Hanson Blvd & Northdale Blvd

Site Code : 223

Start Date : 3/1/2016

Page No : 3

Start Time	Hanson Blvd Southbound					Northdale Blvd Westbound					Hanson Blvd Northbound					Northdale Blvd Eastbound					Int. Total
	Left	Thru	Right	Other	App. Total	Left	Thru	Right	Other	App. Total	Left	Thru	Right	Other	App. Total	Left	Thru	Right	Other	App. Total	
Peak Hour Analysis From 06:00 to 11:45 - Peak 1 of 1																					
Peak Hour for Entire Intersection Begins at 07:00																					
07:00	0	475	25	0	500	35	18	2	0	55	17	119	43	0	179	10	16	34	0	60	794
07:15	7	547	14	0	568	68	24	2	0	94	6	113	55	0	174	9	15	49	0	73	909
07:30	6	503	23	1	533	56	22	1	0	79	27	130	74	0	231	8	8	36	0	52	895
07:45	12	418	15	0	445	43	19	2	0	64	29	135	74	0	238	20	23	39	0	82	829
Total Volume	25	1943	77	1	2046	202	83	7	0	292	79	497	246	0	822	47	62	158	0	267	3427
% App. Total	1.2	95	3.8	0		69.2	28.4	2.4	0		9.6	60.5	29.9	0		17.6	23.2	59.2	0		
PHF	.521	.888	.770	.250	.901	.743	.865	.875	.000	.777	.681	.920	.831	.000	.863	.588	.674	.806	.000	.814	.943

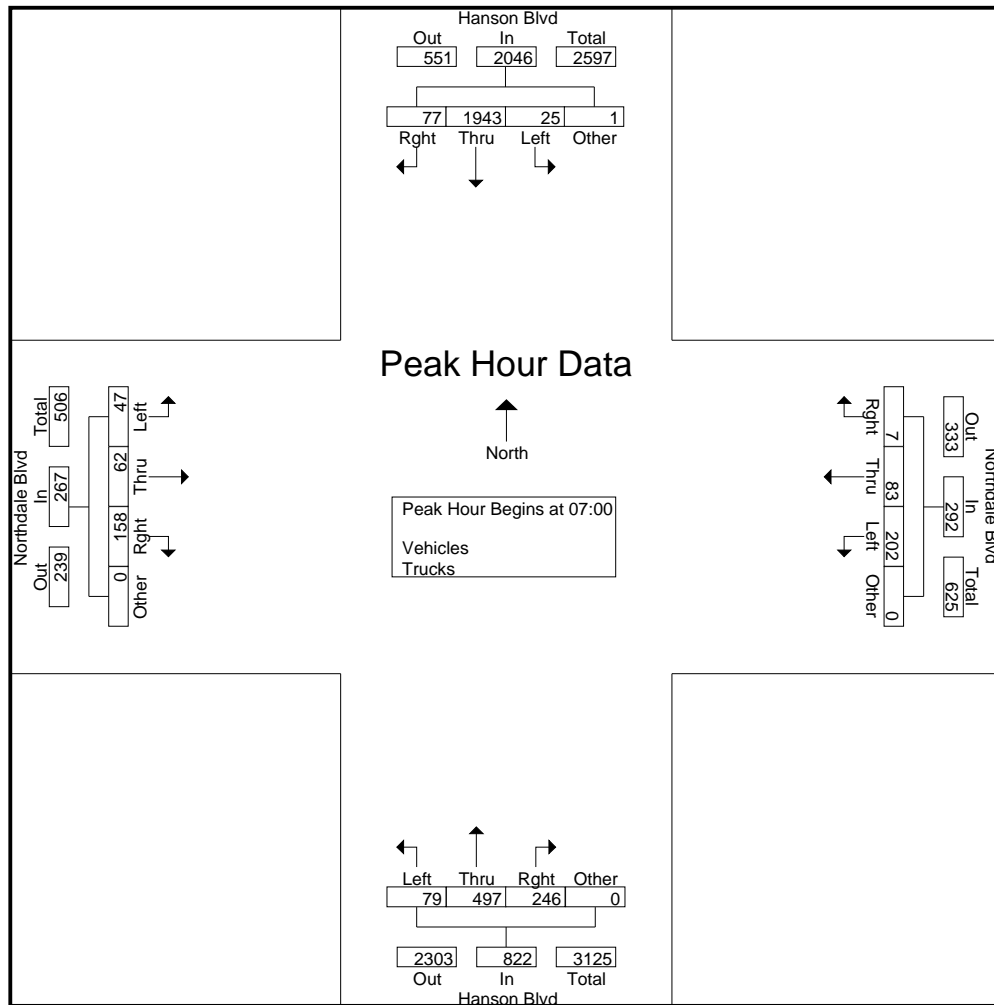

Alliant Engineering

Minneapolis, MN 55415

--TRAFFIC DATA --

Hanson Blvd at Northdale Blvd

Ref.Pt.:

Alliant Eng.

TURN MOVEMENT COUNT

File Name : 223_Hanson Blvd & Northdale Blvd

Site Code : 223

Start Date : 3/1/2016

Page No : 4

Start Time	Hanson Blvd Southbound					Northdale Blvd Westbound					Hanson Blvd Northbound					Northdale Blvd Eastbound					Int. Total
	Left	Thru	Rght	Other	App. Total	Left	Thru	Rght	Other	App. Total	Left	Thru	Rght	Other	App. Total	Left	Thru	Rght	Other	App. Total	
Peak Hour Analysis From 12:00 to 17:45 - Peak 1 of 1																					
Peak Hour for Entire Intersection Begins at 16:15																					
16:15	23	179	6	0	208	68	7	18	0	93	24	331	48	0	403	37	16	12	0	65	769
16:30	13	184	2	0	199	116	10	36	0	162	19	316	49	0	384	28	11	7	0	46	791
16:45	20	193	5	0	218	71	12	27	0	110	37	297	67	0	401	27	9	14	0	50	779
17:00	8	133	7	0	148	53	17	29	0	99	34	479	64	0	577	25	22	9	0	56	880
Total Volume	64	689	20	0	773	308	46	110	0	464	114	1423	228	0	1765	117	58	42	0	217	3219
% App. Total	8.3	89.1	2.6	0		66.4	9.9	23.7	0		6.5	80.6	12.9	0		53.9	26.7	19.4	0		
PHF	.696	.892	.714	.000	.886	.664	.676	.764	.000	.716	.770	.743	.851	.000	.765	.791	.659	.750	.000	.835	.914

