

Alliant Engineering Inc Minneapolis, MN 55415

TH-101 at I-94, South Ramps
Ref.Pt.: 039.640
data by Alliant Engineering Inc
TURN MOVEMENT COUNT

File Name : TH-101 at I-94 south ramps 2009
Site Code : 00000026
Start Date : 1/21/2009
Page No : 1

Groups Printed- Unshifted

Start Time	TH-101 Southbound				ramp to EB I-94 Westbound				TH-101 Northbound				ramp from EB I-94 Eastbound				Int. Total
	Left	Thru	Right	Peds	Left	Thru	Right	Peds	Left	Thru	Right	Peds	Left	Thru	Right	Peds	
06:00	0	157	385	0	0	0	0	0	0	32	90	0	26	0	51	0	741
06:15	0	235	383	0	0	0	0	0	0	39	103	0	33	0	67	0	860
06:30	0	218	358	0	0	0	0	0	0	69	100	0	33	0	64	0	842
06:45	0	224	350	0	0	0	0	0	0	62	71	0	44	0	72	0	823
Total	0	834	1476	0	0	0	0	0	0	202	364	0	136	0	254	0	3266
07:00	0	249	331	0	0	0	0	0	0	90	54	0	25	0	83	1	833
07:15	0	228	271	0	0	0	0	0	0	159	43	0	42	0	83	0	826
07:30	0	274	285	0	0	0	0	0	0	150	30	0	46	0	104	0	889
07:45	0	277	242	0	0	0	0	0	0	90	40	0	86	0	119	0	854
Total	0	1028	1129	0	0	0	0	0	0	489	167	0	199	0	389	1	3402
08:00	0	144	237	0	0	0	0	0	0	68	44	0	53	0	67	0	613
08:15	0	159	257	0	1	0	0	0	0	77	42	0	29	0	62	0	627
08:30	0	122	242	0	0	0	0	0	0	85	44	0	35	0	46	0	574
08:45	0	138	175	2	0	0	0	0	0	87	35	1	49	0	51	0	538
Total	0	563	911	2	1	0	0	0	0	317	165	1	166	0	226	0	2352
09:00	0	102	254	0	0	0	0	0	0	104	46	0	22	0	42	0	570
09:15	0	105	184	0	0	0	0	0	0	96	34	0	40	0	37	0	496
*** BREAK ***																	
Total	0	207	438	0	0	0	0	0	0	200	80	0	62	0	79	0	1066
*** BREAK ***																	
10:30	0	104	154	0	0	0	0	0	0	75	35	0	31	0	23	0	422
10:45	0	91	146	0	0	0	0	0	0	75	34	0	31	0	27	0	404
Total	0	195	300	0	0	0	0	0	0	150	69	0	62	0	50	0	826
11:00	0	99	159	0	0	0	0	0	0	96	27	0	37	0	24	1	443
11:15	0	123	162	0	0	0	0	0	0	107	35	0	38	0	30	0	495
11:30	0	104	159	0	0	0	0	0	0	146	24	0	45	0	22	0	500
11:45	0	112	138	0	0	0	0	0	0	143	17	0	44	0	29	0	483
Total	0	438	618	0	0	0	0	0	0	492	103	0	164	0	105	1	1921
12:00	0	127	136	0	0	0	0	0	0	135	25	0	50	0	22	0	495
12:15	0	110	133	0	0	0	0	0	0	123	38	0	43	0	25	0	472
12:30	0	121	156	0	0	0	0	0	0	126	31	0	40	0	36	0	510
12:45	0	125	166	0	0	0	0	0	0	104	29	0	37	0	21	0	482
Total	0	483	591	0	0	0	0	0	0	488	123	0	170	0	104	0	1959
13:00	0	105	152	0	0	0	0	0	0	171	32	0	50	0	28	0	538
13:15	0	110	172	0	0	0	0	0	0	142	34	0	58	0	28	0	544
*** BREAK ***																	
Total	0	215	324	0	0	0	0	0	0	313	66	0	108	0	56	0	1082
*** BREAK ***																	
14:30	0	145	148	0	0	0	0	0	0	142	23	0	45	0	35	0	538
14:45	0	160	132	0	0	0	0	0	0	150	29	0	48	0	35	0	554
Total	0	305	280	0	0	0	0	0	0	292	52	0	93	0	70	0	1092
15:00	0	147	148	0	0	0	0	0	0	192	36	0	52	1	36	0	612
15:15	0	148	149	0	0	0	0	0	0	170	26	0	44	0	39	0	576
15:30	0	143	173	0	0	0	0	0	0	247	28	0	40	0	40	0	671
15:45	0	167	152	0	0	0	0	0	0	261	34	0	51	0	27	0	692
Total	0	605	622	0	0	0	0	0	0	870	124	0	187	1	142	0	2551

Alliant Engineering Inc Minneapolis, MN 55415

TH-101 at I-94, South Ramps
 Ref.Pt.: 039.640
 data by Alliant Engineering Inc
 TURN MOVEMENT COUNT

File Name : TH-101 at I-94 south ramps 2009
 Site Code : 00000026
 Start Date : 1/21/2009
 Page No : 2

Groups Printed- Unshifted

Start Time	TH-101 Southbound				ramp to EB I-94 Westbound				TH-101 Northbound				ramp from EB I-94 Eastbound				Int. Total
	Left	Thru	Right	Peds	Left	Thru	Right	Peds	Left	Thru	Right	Peds	Left	Thru	Right	Peds	
16:00	0	192	168	0	0	0	0	0	0	278	41	0	44	0	24	0	747
16:15	0	207	175	0	0	0	0	0	0	285	39	0	53	0	35	0	794
16:30	0	173	144	0	0	0	0	0	0	312	39	0	41	0	37	0	746
16:45	1	185	201	0	0	0	0	0	0	303	38	0	54	0	39	0	821
Total	1	757	688	0	0	0	0	0	0	1178	157	0	192	0	135	0	3108
17:00	0	172	165	0	0	0	0	0	0	335	46	0	50	0	26	0	794
17:15	0	212	225	0	0	0	0	0	0	286	22	0	59	0	43	0	847
17:30	0	198	145	0	0	0	0	0	0	246	43	0	64	0	27	0	723
17:45	0	220	176	0	0	0	0	0	0	275	24	0	38	0	47	0	780
Total	0	802	711	0	0	0	0	0	0	1142	135	0	211	0	143	0	3144
Grand Total	1	6432	8088	2	1	0	0	0	0	6133	1605	1	1750	1	1753	2	25769
Apprch %	0	44.3	55.7	0	100	0	0	0	0	79.2	20.7	0	49.9	0	50	0.1	
Total %	0	25	31.4	0	0	0	0	0	0	23.8	6.2	0	6.8	0	6.8	0	

Alliant Engineering Inc Minneapolis, MN 55415

TH-101 at I-94, South Ramps
 Ref.Pt.: 039.640
 data by Alliant Engineering Inc
 TURN MOVEMENT COUNT

File Name : TH-101 at I-94 south ramps 2009
 Site Code : 00000026
 Start Date : 1/21/2009
 Page No : 3

Start Time	TH-101 Southbound					ramp to EB I-94 Westbound					TH-101 Northbound					ramp from EB I-94 Eastbound					Int. Total
	Left	Thru	Right	Peds	App. Total	Left	Thru	Right	Peds	App. Total	Left	Thru	Right	Peds	App. Total	Left	Thru	Right	Peds	App. Total	
Peak Hour Analysis From 06:00 to 08:45 - Peak 1 of 1																					
Peak Hour for Entire Intersection Begins at 07:00																					
07:00	0	249	331	0	580	0	0	0	0	0	0	90	54	0	144	25	0	83	1	109	833
07:15	0	228	271	0	499	0	0	0	0	0	0	159	43	0	202	42	0	83	0	125	826
07:30	0	274	285	0	559	0	0	0	0	0	0	150	30	0	180	46	0	104	0	150	889
07:45	0	277	242	0	519	0	0	0	0	0	0	90	40	0	130	86	0	119	0	205	854
Total Volume	0	1028	1129	0	2157	0	0	0	0	0	0	489	167	0	656	199	0	389	1	589	3402
% App. Total	0	47.7	52.3	0		0	0	0	0		0	74.5	25.5	0		33.8	0	66	0.2		
PHF	.000	.928	.853	.000	.930	.000	.000	.000	.000	.000	.000	.769	.773	.000	.812	.578	.000	.817	.250	.718	.957

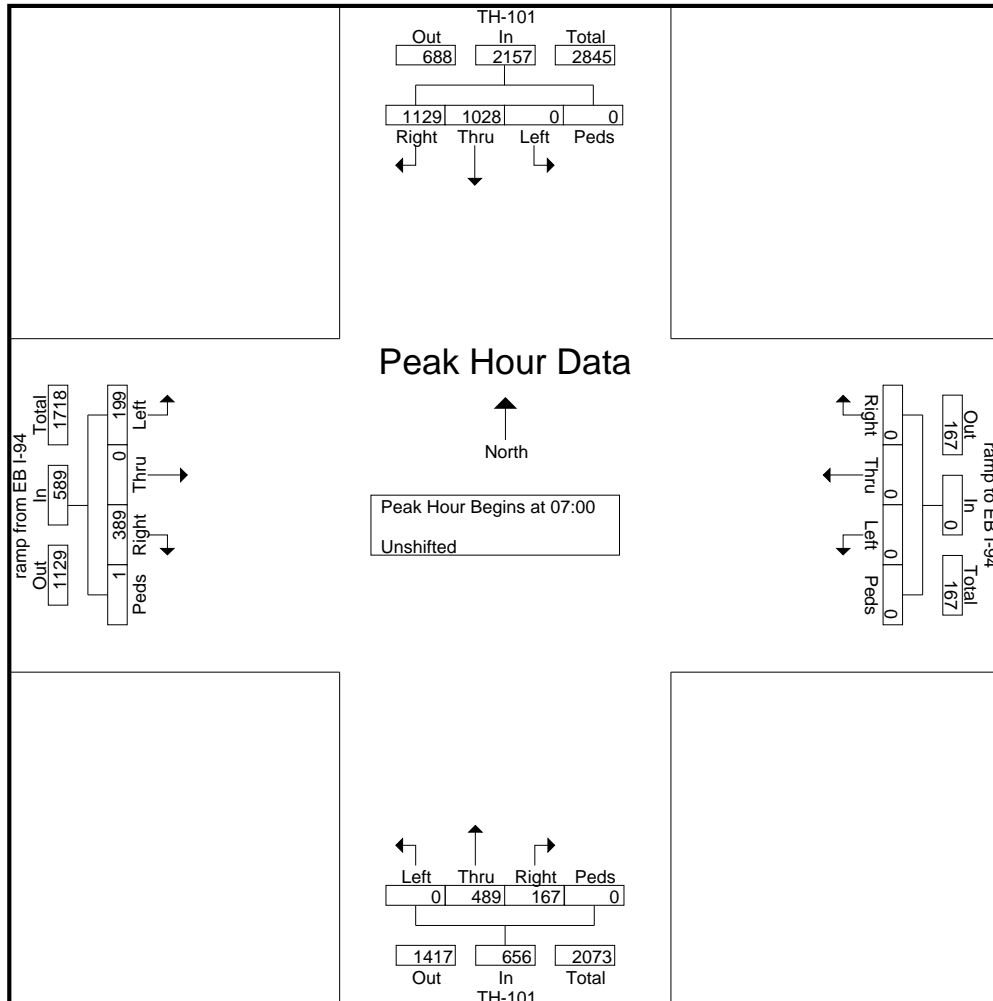

Alliant Engineering Inc Minneapolis, MN 55415

TH-101 at I-94, South Ramps
 Ref.Pt.: 039.640
 data by Alliant Engineering Inc
 TURN MOVEMENT COUNT

File Name : TH-101 at I-94 south ramps 2009
 Site Code : 00000026
 Start Date : 1/21/2009
 Page No : 4

Start Time	TH-101 Southbound					ramp to EB I-94 Westbound					TH-101 Northbound					ramp from EB I-94 Eastbound					Int. Total
	Left	Thru	Right	Peds	App. Total	Left	Thru	Right	Peds	App. Total	Left	Thru	Right	Peds	App. Total	Left	Thru	Right	Peds	App. Total	
Peak Hour Analysis From 15:00 to 17:45 - Peak 1 of 1																					
Peak Hour for Entire Intersection Begins at 16:30																					
16:30	0	173	144	0	317	0	0	0	0	0	0	312	39	0	351	41	0	37	0	78	746
16:45	1	185	201	0	387	0	0	0	0	0	0	303	38	0	341	54	0	39	0	93	821
17:00	0	172	165	0	337	0	0	0	0	0	0	335	46	0	381	50	0	26	0	76	794
17:15	0	212	225	0	437	0	0	0	0	0	0	286	22	0	308	59	0	43	0	102	847
Total Volume	1	742	735	0	1478	0	0	0	0	0	0	1236	145	0	1381	204	0	145	0	349	3208
% App. Total	0.1	50.2	49.7	0		0	0	0	0	0	0	89.5	10.5	0		58.5	0	41.5	0		
PHF	.250	.875	.817	.000	.846	.000	.000	.000	.000	.000	.000	.922	.788	.000	.906	.864	.000	.843	.000	.855	.947

