



# MINNESOTA DEPT OF TRANSPORTATION

## TRAFFIC DATA COLLECTION - METRO

TH-13 at Franklin Trail, PRIOR LAKE

Ref.Pt.: 085.892

JAMAR # T-2638 CAH

TURN MOVEMENT COUNT

File Name : th-13 at franklin trail 2010

Site Code : 00000000

Start Date : 3/16/2010

Page No : 1

### Groups Printed- Cars & Trucks

Start Time	TH-13 Southbound				Franklin Trail Westbound				TH-13 Northbound				commercial entrance Eastbound				Int. Total	
	Left	Thru	Right	Peds	Left	Thru	Right	Peds	Left	Thru	Right	Peds	Left	Thru	Right	Peds		
06:00	4	17	0	0	0	0	16	0	0	66	0	0	0	0	0	0	0	103
06:15	4	15	0	0	0	0	36	0	0	87	0	0	0	0	0	0	0	142
06:30	3	23	0	0	0	0	31	0	0	86	1	0	0	0	0	0	0	144
06:45	6	45	0	0	0	0	28	0	0	109	1	0	0	0	0	0	0	189
Total	17	100	0	0	0	0	111	0	0	348	2	0	0	0	0	0	0	578
07:00	12	31	0	0	0	0	40	0	0	139	2	0	0	0	0	0	0	224
07:15	8	75	1	0	0	0	43	1	0	140	2	0	0	0	0	0	0	270
07:30	8	39	0	0	1	0	29	0	0	176	7	0	0	0	0	0	0	260
07:45	33	46	0	0	0	0	43	0	0	153	5	0	0	0	0	0	0	280
Total	61	191	1	0	1	0	155	1	0	608	16	0	0	0	0	0	0	1034
08:00	17	45	0	0	3	0	30	0	0	104	7	0	0	0	0	0	0	206
08:15	23	56	0	0	3	0	43	1	0	148	3	0	1	0	0	0	0	278
08:30	20	61	0	0	0	0	58	0	0	117	4	0	0	0	0	0	0	260
08:45	15	51	0	0	2	0	32	0	0	106	6	0	0	0	0	0	0	212
Total	75	213	0	0	8	0	163	1	0	475	20	0	1	0	0	0	0	956
*** BREAK ***																		
14:45	41	114	0	0	0	0	27	0	0	100	4	0	0	0	0	0	0	286
Total	41	114	0	0	0	0	27	0	0	100	4	0	0	0	0	0	0	286
15:00	34	136	0	0	5	1	27	0	1	107	7	0	0	0	1	0	0	319
15:15	30	152	1	0	2	0	26	0	0	103	7	0	2	0	0	0	0	323
15:30	35	116	1	0	2	1	24	0	0	119	7	0	0	0	2	0	0	307
15:45	33	153	2	0	4	0	32	0	0	91	8	0	0	2	0	0	0	325
Total	132	557	4	0	13	2	109	0	1	420	29	0	2	2	3	0	0	1274
16:00	47	148	0	0	2	0	35	0	1	92	3	0	0	0	2	0	0	330
16:15	31	115	0	0	2	0	17	0	0	91	3	0	0	0	2	0	0	261
16:30	53	162	1	0	7	2	39	0	0	100	7	0	0	0	1	0	0	372
16:45	44	158	1	0	2	1	37	0	1	97	6	0	0	0	0	0	0	347
Total	175	583	2	0	13	3	128	0	2	380	19	0	0	0	5	0	0	1310
17:00	52	150	3	0	6	1	29	0	0	125	5	0	0	0	1	0	0	372
17:15	43	176	2	0	4	0	23	0	4	125	1	0	0	0	2	0	0	380
17:30	53	136	3	0	1	0	31	0	4	91	3	0	3	1	0	0	0	326
17:45	47	149	1	0	1	0	30	0	0	97	4	0	3	1	0	0	0	333
Total	195	611	9	0	12	1	113	0	8	438	13	0	6	2	3	0	0	1411
Grand Total	696	2369	16	0	47	6	806	2	11	2769	103	0	9	4	11	0	0	6849
Apprch %	22.6	76.9	0.5	0	5.5	0.7	93.6	0.2	0.4	96	3.6	0	37.5	16.7	45.8	0	0	
Total %	10.2	34.6	0.2	0	0.7	0.1	11.8	0	0.2	40.4	1.5	0	0.1	0.1	0.2	0	0	



# MINNESOTA DEPT OF TRANSPORTATION

## TRAFFIC DATA COLLECTION - METRO

TH-13 at Franklin Trail, PRIOR LAKE  
 Ref.Pt.: 085.892  
 JAMAR # T-2638 CAH  
 TURN MOVEMENT COUNT

File Name : th-13 at franklin trail 2010  
 Site Code : 00000000  
 Start Date : 3/16/2010  
 Page No : 2

Start Time	TH-13 Southbound					Franklin Trail Westbound					TH-13 Northbound					commercial entrance Eastbound					Int. Total
	Left	Thru	Right	Peds	App. Total	Left	Thru	Right	Peds	App. Total	Left	Thru	Right	Peds	App. Total	Left	Thru	Right	Peds	App. Total	
Peak Hour Analysis From 06:00 to 08:45 - Peak 1 of 1																					
Peak Hour for Entire Intersection Begins at 07:00																					
07:00	12	31	0	0	43	0	0	40	0	40	0	139	2	0	141	0	0	0	0	0	224
07:15	8	75	1	0	84	0	0	43	1	44	0	140	2	0	142	0	0	0	0	0	270
07:30	8	39	0	0	47	1	0	29	0	30	0	176	7	0	183	0	0	0	0	0	260
07:45	33	46	0	0	79	0	0	43	0	43	0	153	5	0	158	0	0	0	0	0	280
Total Volume	61	191	1	0	253	1	0	155	1	157	0	608	16	0	624	0	0	0	0	0	1034
% App. Total	24.1	75.5	0.4	0		0.6	0	98.7	0.6		0	97.4	2.6	0		0	0	0	0		
PHF	.462	.637	.250	.000	.753	.250	.000	.901	.250	.892	.000	.864	.571	.000	.852	.000	.000	.000	.000	.000	.923

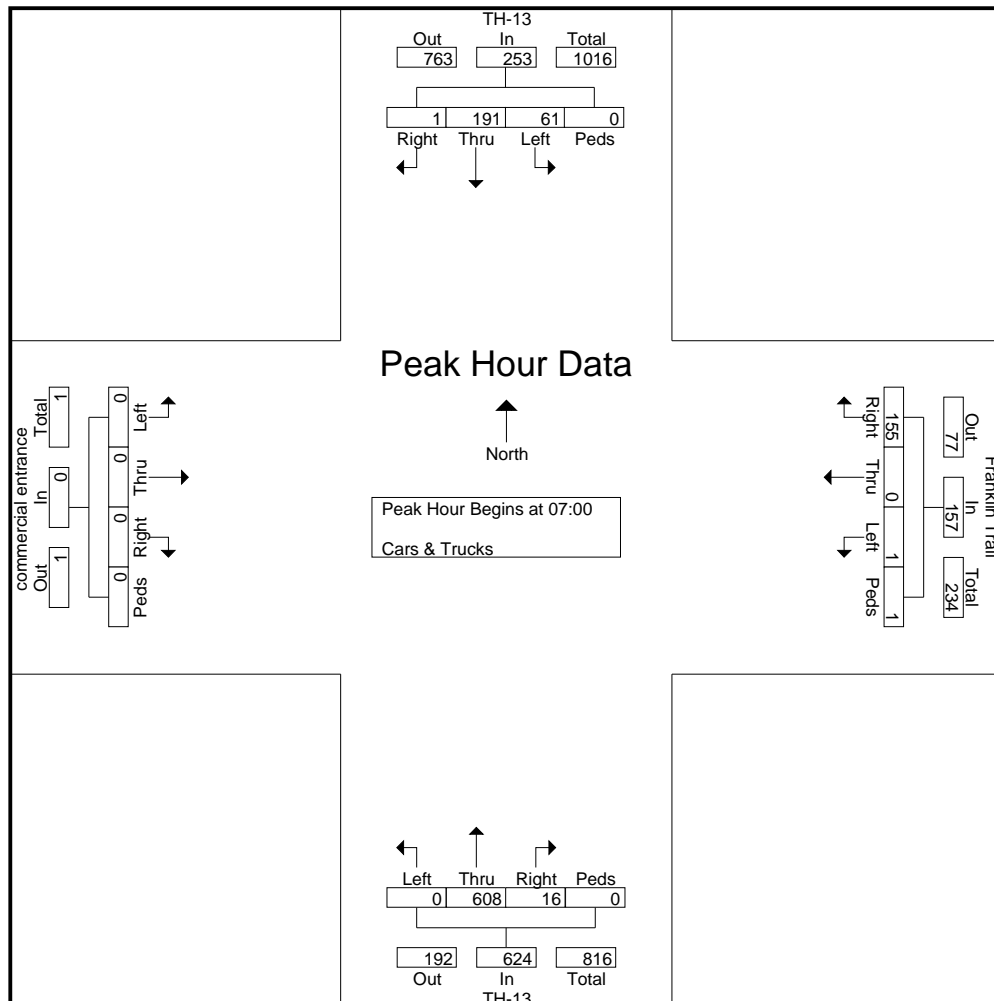



# MINNESOTA DEPT OF TRANSPORTATION

## TRAFFIC DATA COLLECTION - METRO

TH-13 at Franklin Trail, PRIOR LAKE  
 Ref.Pt.: 085.892  
 JAMAR # T-2638 CAH  
 TURN MOVEMENT COUNT

File Name : th-13 at franklin trail 2010  
 Site Code : 00000000  
 Start Date : 3/16/2010  
 Page No : 3

Start Time	TH-13 Southbound					Franklin Trail Westbound					TH-13 Northbound					commercial entrance Eastbound					Int. Total
	Left	Thru	Right	Peds	App. Total	Left	Thru	Right	Peds	App. Total	Left	Thru	Right	Peds	App. Total	Left	Thru	Right	Peds	App. Total	
Peak Hour Analysis From 15:00 to 17:45 - Peak 1 of 1																					
Peak Hour for Entire Intersection Begins at 16:30																					
16:30	53	162	1	0	216	7	2	39	0	48	0	100	7	0	107	0	0	1	0	1	372
16:45	44	158	1	0	203	2	1	37	0	40	1	97	6	0	104	0	0	0	0	0	347
17:00	52	150	3	0	205	6	1	29	0	36	0	125	5	0	130	0	0	1	0	1	372
17:15	43	176	2	0	221	4	0	23	0	27	4	125	1	0	130	0	0	2	0	2	380
Total Volume	192	646	7	0	845	19	4	128	0	151	5	447	19	0	471	0	0	4	0	4	1471
% App. Total	22.7	76.4	0.8	0		12.6	2.6	84.8	0		1.1	94.9	4	0		0	0	100	0		
PHF	.906	.918	.583	.000	.956	.679	.500	.821	.000	.786	.313	.894	.679	.000	.906	.000	.000	.500	.000	.500	.968

