



MINNESOTA DEPT OF TRANSPORTATION
TRAFFIC DATA COLLECTION - METRO

TH-169 AT 85TH AVE. N, (BROOKLYN PARK)
REF.PT.: 139.786
JAMAR # 631/632 RE/DR
TURN MOVEMENT COUNT

File Name : th-169 at 85th ave 2006 am pm
Site Code : 00000000
Start Date : 10/25/2006
Page No : 1

Groups Printed- Cars & Trucks

Start Time	TH-169 Southbound				85TH AVE. Westbound				TH-169 Northbound				85TH AVE. Eastbound				Int. Total
	Left	Thru	Right	Peds	Left	Thru	Right	Peds	Left	Thru	Right	Peds	Left	Thru	Right	Peds	
06:00	1	536	38	0	68	55	1	0	0	138	47	0	8	19	2	0	913
06:15	3	477	18	0	97	79	3	0	1	200	50	0	26	43	1	0	998
06:30	4	434	22	0	104	92	3	0	1	264	69	0	29	42	2	0	1066
06:45	5	453	29	0	94	151	2	0	0	297	110	0	19	70	2	0	1232
Total	13	1900	107	0	363	377	9	0	2	899	276	0	82	174	7	0	4209
07:00	1	428	14	0	111	160	5	0	0	264	68	0	44	57	2	0	1154
07:15	3	484	22	0	98	169	12	0	1	357	104	0	27	81	3	0	1361
07:30	6	442	37	0	110	176	3	0	0	351	124	0	47	121	3	0	1420
07:45	8	437	37	0	106	193	5	0	1	393	184	0	46	111	1	0	1522
Total	18	1791	110	0	425	698	25	0	2	1365	480	0	164	370	9	0	5457
08:00	8	442	36	0	95	122	7	0	1	326	122	0	25	111	0	0	1295
08:15	18	426	45	0	102	111	9	0	1	282	118	0	51	109	3	0	1275
08:30	16	409	29	0	76	89	5	0	4	281	127	0	42	115	2	0	1195
08:45	22	376	57	0	90	117	12	0	4	271	168	0	53	148	2	0	1320
Total	64	1653	167	0	363	439	33	0	10	1160	535	0	171	483	7	0	5085
*** BREAK ***																	
15:00	35	349	52	0	79	103	26	0	2	490	111	0	54	163	7	0	1471
15:15	21	286	29	0	59	104	17	1	1	556	118	0	50	112	2	0	1356
15:30	26	324	50	0	67	135	23	0	3	516	140	0	72	218	2	0	1576
15:45	27	298	52	0	73	117	29	0	0	560	144	0	64	219	7	0	1590
Total	109	1257	183	0	278	459	95	1	6	2122	513	0	240	712	18	0	5993
16:00	27	354	62	0	62	95	32	0	5	590	123	0	48	202	2	0	1602
16:15	22	388	42	0	86	97	35	0	3	530	110	0	55	180	2	0	1550
16:30	27	347	68	0	85	103	16	0	2	558	147	0	62	229	2	0	1646
16:45	25	413	51	0	76	88	21	0	3	546	166	0	51	213	5	0	1658
Total	101	1502	223	0	309	383	104	0	13	2224	546	0	216	824	11	0	6456
17:00	31	371	48	0	89	131	26	1	1	574	137	0	82	206	1	0	1698
17:15	29	367	53	0	61	107	19	0	2	634	133	0	66	223	3	0	1697
17:30	20	376	57	0	85	120	33	0	3	530	129	0	67	252	1	0	1673
17:45	29	337	69	0	70	122	22	0	1	527	134	0	55	199	2	0	1567
Total	109	1451	227	0	305	480	100	1	7	2265	533	0	270	880	7	0	6635
Grand Total	414	9554	1017	0	2043	2836	366	2	40	10035	2883	0	1143	3443	59	0	33835
Apprch %	3.8	87	9.3	0	38.9	54	7	0	0.3	77.4	22.2	0	24.6	74.1	1.3	0	
Total %	1.2	28.2	3	0	6	8.4	1.1	0	0.1	29.7	8.5	0	3.4	10.2	0.2	0	



MINNESOTA DEPT OF TRANSPORTATION

TRAFFIC DATA COLLECTION - METRO

TH-169 AT 85TH AVE. N, (BROOKLYN PARK)
 REF.PT.: 139.786
 JAMAR # 631/632 RE/DR
 TURN MOVEMENT COUNT

File Name : th-169 at 85th ave 2006 am pm
 Site Code : 00000000
 Start Date : 10/25/2006
 Page No : 2

Start Time	TH-169 Southbound					85TH AVE. Westbound					TH-169 Northbound					85TH AVE. Eastbound					Int. Total
	Left	Thru	Right	Peds	App. Total	Left	Thru	Right	Peds	App. Total	Left	Thru	Right	Peds	App. Total	Left	Thru	Right	Peds	App. Total	
Peak Hour Analysis From 06:00 to 08:45 - Peak 1 of 1																					
Peak Hour for Entire Intersection Begins at 07:15																					
07:15	3	484	22	0	509	98	169	12	0	279	1	357	104	0	462	27	81	3	0	111	1361
07:30	6	442	37	0	485	110	176	3	0	289	0	351	124	0	475	47	121	3	0	171	1420
07:45	8	437	37	0	482	106	193	5	0	304	1	393	184	0	578	46	111	1	0	158	1522
08:00	8	442	36	0	486	95	122	7	0	224	1	326	122	0	449	25	111	0	0	136	1295
Total Volume	25	1805	132	0	1962	409	660	27	0	1096	3	1427	534	0	1964	145	424	7	0	576	5598
% App. Total	1.3	92	6.7	0		37.3	60.2	2.5	0		0.2	72.7	27.2	0		25.2	73.6	1.2	0		
PHF	.781	.932	.892	.000	.964	.930	.855	.563	.000	.901	.750	.908	.726	.000	.849	.771	.876	.583	.000	.842	.920

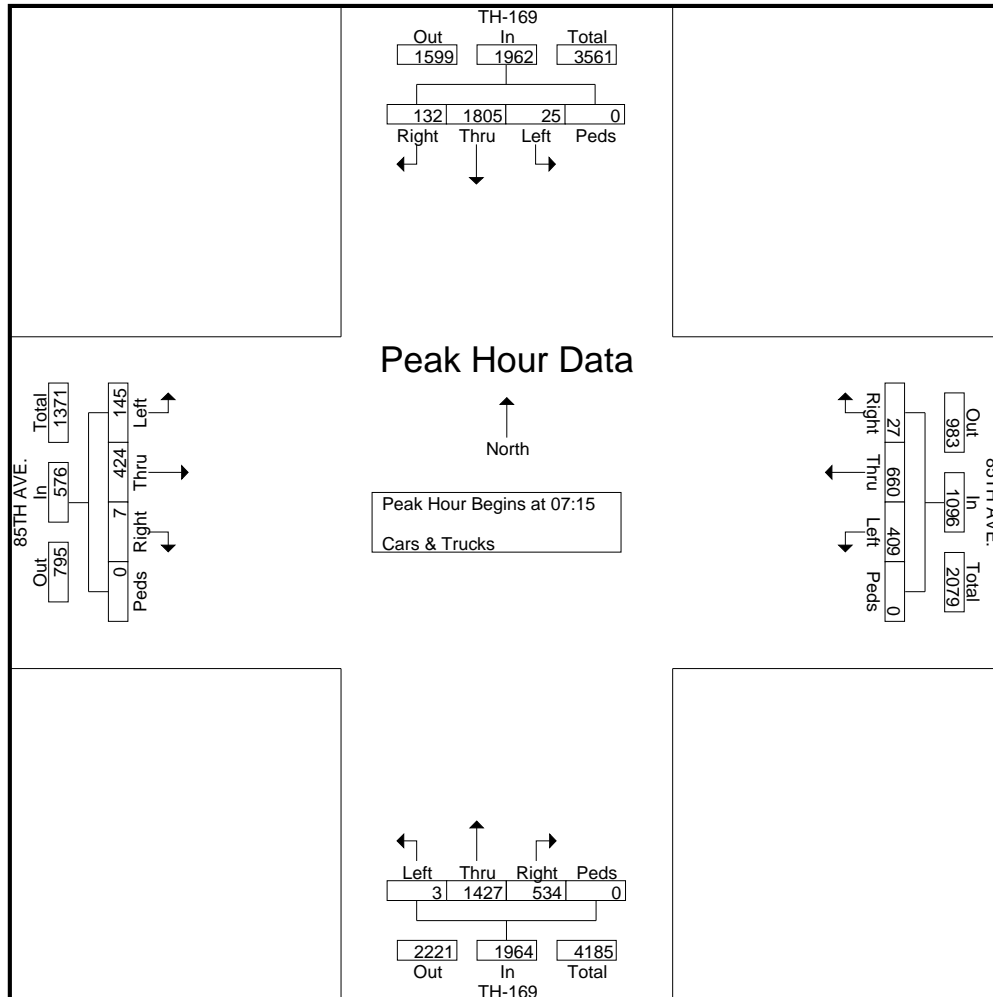



MINNESOTA DEPT OF TRANSPORTATION

TRAFFIC DATA COLLECTION - METRO

TH-169 AT 85TH AVE. N, (BROOKLYN PARK)
 REF.PT.: 139.786
 JAMAR # 631/632 RE/DR
 TURN MOVEMENT COUNT

File Name : th-169 at 85th ave 2006 am pm
 Site Code : 00000000
 Start Date : 10/25/2006
 Page No : 3

Start Time	TH-169 Southbound					85TH AVE. Westbound					TH-169 Northbound					85TH AVE. Eastbound					Int. Total
	Left	Thru	Right	Peds	App. Total	Left	Thru	Right	Peds	App. Total	Left	Thru	Right	Peds	App. Total	Left	Thru	Right	Peds	App. Total	
Peak Hour Analysis From 15:00 to 17:45 - Peak 1 of 1																					
Peak Hour for Entire Intersection Begins at 16:45																					
16:45	25	413	51	0	489	76	88	21	0	185	3	546	166	0	715	51	213	5	0	269	1658
17:00	31	371	48	0	450	89	131	26	1	247	1	574	137	0	712	82	206	1	0	289	1698
17:15	29	367	53	0	449	61	107	19	0	187	2	634	133	0	769	66	223	3	0	292	1697
17:30	20	376	57	0	453	85	120	33	0	238	3	530	129	0	662	67	252	1	0	320	1673
Total Volume	105	1527	209	0	1841	311	446	99	1	857	9	2284	565	0	2858	266	894	10	0	1170	6726
% App. Total	5.7	82.9	11.4	0		36.3	52	11.6	0.1		0.3	79.9	19.8	0		22.7	76.4	0.9	0		
PHF	.847	.924	.917	.000	.941	.874	.851	.750	.250	.867	.750	.901	.851	.000	.929	.811	.887	.500	.000	.914	.990

