

TH-212 at Dell Rd, North ramps
 Ref.Pt.: 154.974 Eden Prairie, MN
 Data by: CountingCars
 TURN MOVEMENT COUNTS

File Name : TH-212 at Dell Rd north ramps 2012
 Site Code : 10312011
 Start Date : 1/11/2012
 Page No : 1

Groups Printed- Cars - Heavy Vehicles

Start Time	Dell Rd Southbound				Linwood Ct Westbound				Dell Rd Northbound				loop from / ramp to WB TH-212 Eastbound				Int. Total
	Left	Thru	Right	Bikes	Left	Thru	Right	Bikes	Left	Thru	Right	Bikes	Left	Thru	Right	Bikes	
06:00	0	11	3	0	3	0	2	0	1	17	0	0	3	0	2	0	42
06:15	0	24	5	0	7	1	2	2	3	24	0	0	10	0	0	0	78
06:30	0	34	9	0	8	1	1	0	3	45	0	0	17	1	10	0	129
06:45	0	57	7	0	14	2	3	1	4	68	3	0	19	1	6	0	185
Total	0	126	24	0	32	4	8	3	11	154	3	0	49	2	18	0	434
07:00	1	51	10	0	17	3	6	0	7	49	2	0	19	0	12	1	178
07:15	0	79	12	0	16	3	9	0	11	94	1	0	19	3	12	0	259
07:30	2	81	14	0	13	4	13	0	10	99	1	0	19	2	9	0	267
07:45	2	46	17	0	14	0	4	0	11	135	0	0	27	0	19	0	275
Total	5	257	53	0	60	10	32	0	39	377	4	0	84	5	52	1	979
08:00	1	51	8	0	13	0	6	0	11	105	0	0	17	1	11	0	224
08:15	1	72	6	0	8	1	2	1	7	59	0	0	33	1	23	0	214
08:30	4	54	14	1	15	1	1	1	17	47	3	0	27	1	25	0	211
08:45	1	54	10	0	8	1	4	1	31	48	0	0	16	0	21	0	195
Total	7	231	38	1	44	3	13	3	66	259	3	0	93	3	80	0	844
09:00	1	26	4	0	7	0	4	0	11	38	0	0	19	1	17	0	128
09:15	1	36	3	0	1	1	3	1	3	35	1	0	14	1	23	0	123
09:30	1	29	2	0	5	0	2	0	4	27	1	0	15	0	19	0	105
09:45	3	32	4	0	4	0	2	0	3	34	1	0	13	2	16	0	114
Total	6	123	13	0	17	1	11	1	21	134	3	0	61	4	75	0	470
10:00	2	29	4	0	8	0	2	0	6	23	1	0	8	1	11	0	95
10:15	0	31	3	0	2	0	1	1	5	21	0	0	6	0	17	0	87
10:30	2	23	6	0	5	0	1	0	4	24	1	0	6	3	8	0	83
10:45	2	33	6	0	5	0	3	0	5	15	2	0	9	0	17	1	98
Total	6	116	19	0	20	0	7	1	20	83	4	0	29	4	53	1	363
11:00	0	33	5	0	1	0	3	0	6	18	0	0	20	3	22	0	111
11:15	1	27	10	0	4	1	1	0	4	19	2	0	15	3	30	0	117
11:30	4	45	4	0	4	0	1	0	4	20	1	0	14	3	28	0	128
11:45	0	36	5	0	2	0	3	0	5	22	2	0	22	3	24	0	124
Total	5	141	24	0	11	1	8	0	19	79	5	0	71	12	104	0	480
12:00	2	31	6	0	2	0	0	0	6	23	1	0	14	6	20	0	111
12:15	4	35	6	0	5	1	3	0	6	28	2	0	6	6	27	0	129
12:30	1	38	5	0	1	1	4	1	5	21	1	0	16	3	29	0	126
12:45	2	39	4	0	6	1	2	0	4	34	1	0	17	1	30	0	141
Total	9	143	21	0	14	3	9	1	21	106	5	0	53	16	106	0	507
13:00	2	31	4	0	2	1	1	1	4	24	2	0	13	6	26	0	117
13:15	2	38	1	0	5	1	3	0	5	21	1	0	12	3	17	0	109
13:30	1	45	8	0	2	0	3	0	7	21	2	0	16	3	29	0	137
13:45	2	38	6	0	1	1	3	0	6	23	2	0	22	3	22	0	129
Total	7	152	19	0	10	3	10	1	22	89	7	0	63	15	94	0	492
14:00	4	37	6	0	1	1	1	0	4	27	0	0	13	2	36	0	132
14:15	1	30	2	0	3	0	2	0	9	25	0	0	16	4	34	0	126
14:30	2	53	11	0	0	1	0	0	2	42	3	0	19	3	26	0	162
14:45	5	81	8	0	4	0	1	1	5	33	1	0	22	4	36	0	201
Total	12	201	27	0	8	2	4	1	20	127	4	0	70	13	132	0	621
15:00	1	59	8	0	4	1	1	0	5	33	2	0	23	9	28	0	174
15:15	4	57	13	0	4	1	3	0	6	46	4	0	21	6	49	0	214
15:30	2	80	38	0	2	3	4	0	17	39	1	0	30	2	39	0	257
15:45	3	65	11	0	5	1	12	0	9	34	1	0	31	9	48	0	229
Total	10	261	70	0	15	6	20	0	37	152	8	0	105	26	164	0	874

TH-212 at Dell Rd, North ramps
 Ref.Pt.: 154.974 Eden Prairie, MN
 Data by: CountingCars
 TURN MOVEMENT COUNTS

File Name : TH-212 at Dell Rd north ramps 2012
 Site Code : 10312011
 Start Date : 1/11/2012
 Page No : 3

Start Time	Dell Rd Southbound					Linwood Ct Westbound					Dell Rd Northbound					loop from / ramp to WB TH-212 Eastbound					Int. Total
	Left	Thru	Right	Bikes	App. Total	Left	Thru	Right	Bikes	App. Total	Left	Thru	Right	Bikes	App. Total	Left	Thru	Right	Bikes	App. Total	
Peak Hour Analysis From 06:00 to 11:45 - Peak 1 of 1																					
Peak Hour for Entire Intersection Begins at 07:15																					
07:15	0	79	12	0	91	16	3	9	0	28	11	94	1	0	106	19	3	12	0	34	259
07:30	2	81	14	0	97	13	4	13	0	30	10	99	1	0	110	19	2	9	0	30	267
07:45	2	46	17	0	65	14	0	4	0	18	11	135	0	0	146	27	0	19	0	46	275
08:00	1	51	8	0	60	13	0	6	0	19	11	105	0	0	116	17	1	11	0	29	224
Total Volume	5	257	51	0	313	56	7	32	0	95	43	433	2	0	478	82	6	51	0	139	1025
% App. Total	1.6	82.1	16.3	0		58.9	7.4	33.7	0		9	90.6	0.4	0		59	4.3	36.7	0		
PHF	.625	.793	.750	.000	.807	.875	.438	.615	.000	.792	.977	.802	.500	.000	.818	.759	.500	.671	.000	.755	.932

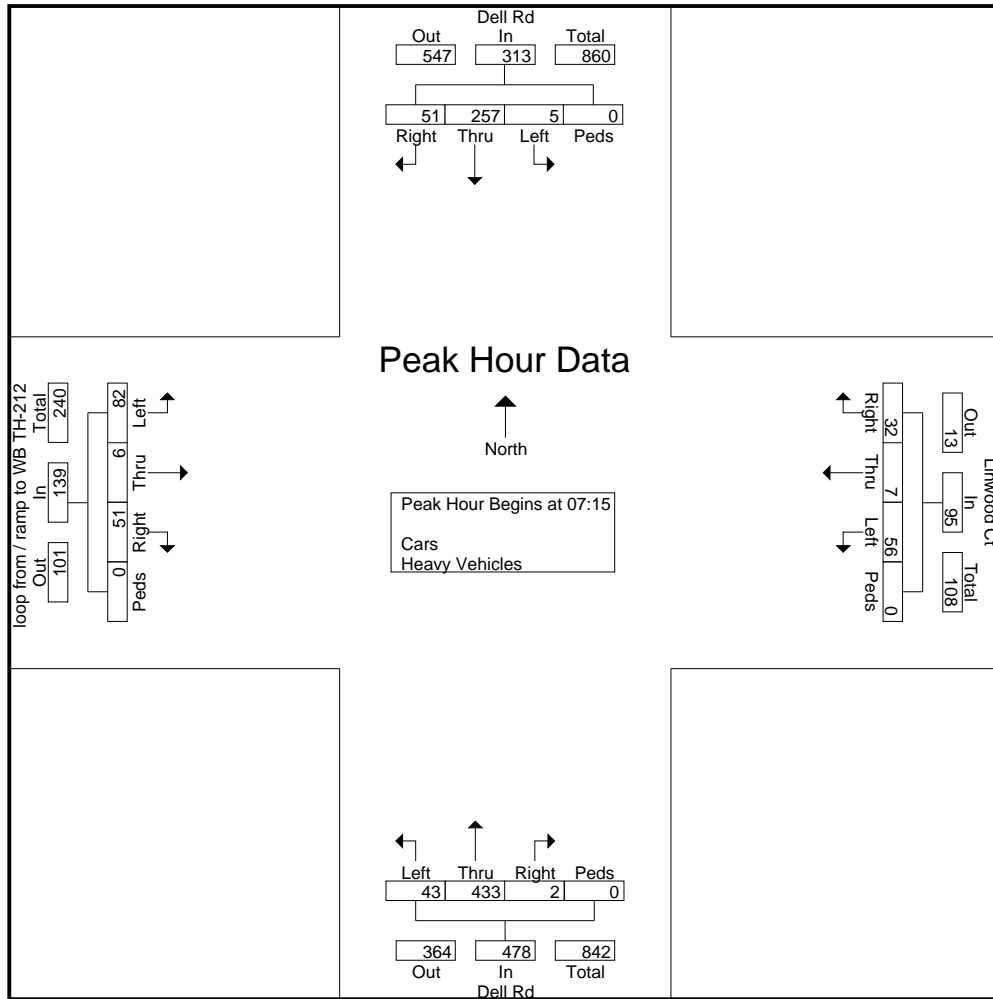

TH-212 at Dell Rd, North ramps
 Ref.Pt.: 154.974 Eden Prairie, MN
 Data by: CountingCars
 TURN MOVEMENT COUNTS

File Name : TH-212 at Dell Rd north ramps 2012
 Site Code : 10312011
 Start Date : 1/11/2012
 Page No : 4

Start Time	Dell Rd Southbound					Linwood Ct Westbound					Dell Rd Northbound					loop from / ramp to WB TH-212 Eastbound					Int. Total
	Left	Thru	Right	Bikes	App. Total	Left	Thru	Right	Bikes	App. Total	Left	Thru	Right	Bikes	App. Total	Left	Thru	Right	Bikes	App. Total	
Peak Hour Analysis From 12:00 to 18:45 - Peak 1 of 1																					
Peak Hour for Entire Intersection Begins at 17:00																					
17:00	7	72	34	0	113	7	0	4	1	12	7	41	3	0	51	46	14	64	0	124	300
17:15	7	73	27	0	107	3	1	4	2	10	7	39	3	0	49	50	16	86	0	152	318
17:30	4	78	27	0	109	4	0	7	2	13	5	48	7	0	60	51	21	59	0	131	313
17:45	4	58	12	0	74	1	2	6	2	11	8	58	3	0	69	54	12	76	0	142	296
Total Volume	22	281	100	0	403	15	3	21	7	46	27	186	16	0	229	201	63	285	0	549	1227
% App. Total	5.5	69.7	24.8	0		32.6	6.5	45.7	15.2		11.8	81.2	7	0		36.6	11.5	51.9	0		
PHF	.786	.901	.735	.000	.892	.536	.375	.750	.875	.885	.844	.802	.571	.000	.830	.931	.750	.828	.000	.903	.965

