

Albeck Gerken, Inc

Transportation Engineers

Traffic Data Collection

TH-212 at Singletree Lane

Ref.Pt.: 158.996

Data by: Albeck Gerken Inc -Radomir/Sue

TURN MOVEMENT COUNT

File Name : TH-212 at Singletree Lane 2004

Site Code : 00000000

Start Date : 12/14/2004

Page No : 1

Groups Printed- Unshifted

Start Time	TH-212 /Flying Cloud Dr Southbound				Mall entrance Westbound				TH-212 /Flying Cloud Dr Northbound				Singletree Lane Eastbound				Int. Total
	Left	Thru	Right	Peds	Left	Thru	Right	Peds	Left	Thru	Right	Peds	Left	Thru	Right	Peds	
06:30	4	41	6	0	1	8	3	0	1	280	3	0	7	5	2	0	361
06:45	3	107	16	0	1	1	2	0	6	315	2	0	13	12	5	0	483
Total	7	148	22	0	2	9	5	0	7	595	5	0	20	17	7	0	844
07:00	3	107	18	0	2	14	5	0	8	370	3	0	14	8	7	0	559
07:15	5	107	21	0	3	9	3	0	9	340	2	0	31	15	3	0	548
07:30	5	149	20	0	4	7	6	0	9	354	3	1	28	22	7	0	615
07:45	10	129	16	0	1	10	8	0	12	345	5	0	35	17	1	0	589
Total	23	492	75	0	10	40	22	0	38	1409	13	1	108	62	18	0	2311
08:00	14	142	28	0	4	6	13	0	8	333	9	0	24	14	5	0	600
08:15	10	116	17	0	6	16	12	0	9	256	7	0	33	20	7	0	509
*** BREAK ***																	
Total	24	258	45	0	10	22	25	0	17	589	16	0	57	34	12	0	1109
*** BREAK ***																	
11:30	52	190	69	0	23	49	16	0	16	219	21	0	33	89	18	0	795
11:45	48	231	55	0	16	49	21	0	33	248	28	0	60	91	21	0	901
Total	100	421	124	0	39	98	37	0	49	467	49	0	93	180	39	0	1696
12:00	52	210	48	0	17	55	42	0	23	280	27	0	42	119	25	0	940
12:15	46	201	47	0	33	52	28	0	23	271	13	0	55	74	22	0	865
12:30	52	188	52	0	21	70	46	0	22	326	17	0	38	83	28	0	943
12:45	37	169	42	0	20	69	40	0	17	295	18	0	56	74	39	0	876
Total	187	768	189	0	91	246	156	0	85	1172	75	0	191	350	114	0	3624
13:00	39	150	44	0	15	71	33	0	23	280	9	0	50	63	18	0	795
13:15	35	164	64	0	18	60	46	0	20	246	9	0	48	74	25	0	809
*** BREAK ***																	
Total	74	314	108	0	33	131	79	0	43	526	18	0	98	137	43	0	1604
*** BREAK ***																	
16:00	32	226	33	0	35	51	14	0	20	184	12	0	36	64	28	0	735
16:15	28	240	38	0	27	41	16	1	20	173	13	0	32	64	26	2	721
16:30	51	273	40	1	27	50	9	0	23	169	9	0	39	75	24	0	790
16:45	50	286	54	2	16	62	12	0	17	169	25	0	36	106	28	0	863
Total	161	1025	165	3	105	204	51	1	80	695	59	0	143	309	106	2	3109
17:00	47	319	67	0	37	71	12	0	15	177	19	0	50	67	24	0	905
17:15	54	301	51	0	26	61	12	0	28	174	17	0	42	63	22	0	851
17:30	36	314	55	0	32	61	28	0	22	164	21	0	43	76	37	1	890
17:45	30	291	36	0	31	56	16	0	28	184	13	0	73	84	25	0	867
Total	167	1225	209	0	126	249	68	0	93	699	70	0	208	290	108	1	3513
Grand Total	743	4651	937	3	416	999	443	1	412	6152	305	1	918	1379	447	3	17810
Apprch %	11.7	73.4	14.8	0	22.4	53.7	23.8	0.1	6	89.5	4.4	0	33.4	50.2	16.3	0.1	
Total %	4.2	26.1	5.3	0	2.3	5.6	2.5	0	2.3	34.5	1.7	0	5.2	7.7	2.5	0	

Albeck Gerken, Inc

Transportation Engineers

Traffic Data Collection

TH-212 at Singletree Lane

Ref.Pt.: 158.996

Data by: Albeck Gerken Inc -Radomir/Sue

TURN MOVEMENT COUNT

File Name : TH-212 at Singletree Lane 2004

Site Code : 00000000

Start Date : 12/14/2004

Page No : 2

	TH-212 /Flying Cloud Dr Southbound					Mall entrance Westbound					TH-212 /Flying Cloud Dr Northbound					Singletree Lane Eastbound					
Start Time	Left	Thru	Right	Peds	App. Total	Left	Thru	Right	Peds	App. Total	Left	Thru	Right	Peds	App. Total	Left	Thru	Right	Peds	App. Total	Int. Total
Peak Hour Analysis From 06:30 to 08:15 - Peak 1 of 1																					
Peak Hour for Entire Intersection Begins at 07:15																					
07:15	5	107	21	0	133	3	9	3	0	15	9	340	2	0	351	31	15	3	0	49	548
07:30	5	149	20	0	174	4	7	6	0	17	9	354	3	1	367	28	22	7	0	57	615
07:45	10	129	16	0	155	1	10	8	0	19	12	345	5	0	362	35	17	1	0	53	589
08:00	14	142	28	0	184	4	6	13	0	23	8	333	9	0	350	24	14	5	0	43	600
Total Volume	34	527	85	0	646	12	32	30	0	74	38	1372	19	1	1430	118	68	16	0	202	2352
% App. Total	5.3	81.6	13.2	0		16.2	43.2	40.5	0		2.7	95.9	1.3	0.1		58.4	33.7	7.9	0		
PHF	.607	.884	.759	.000	.878	.750	.800	.577	.000	.804	.792	.969	.528	.250	.974	.843	.773	.571	.000	.886	.956

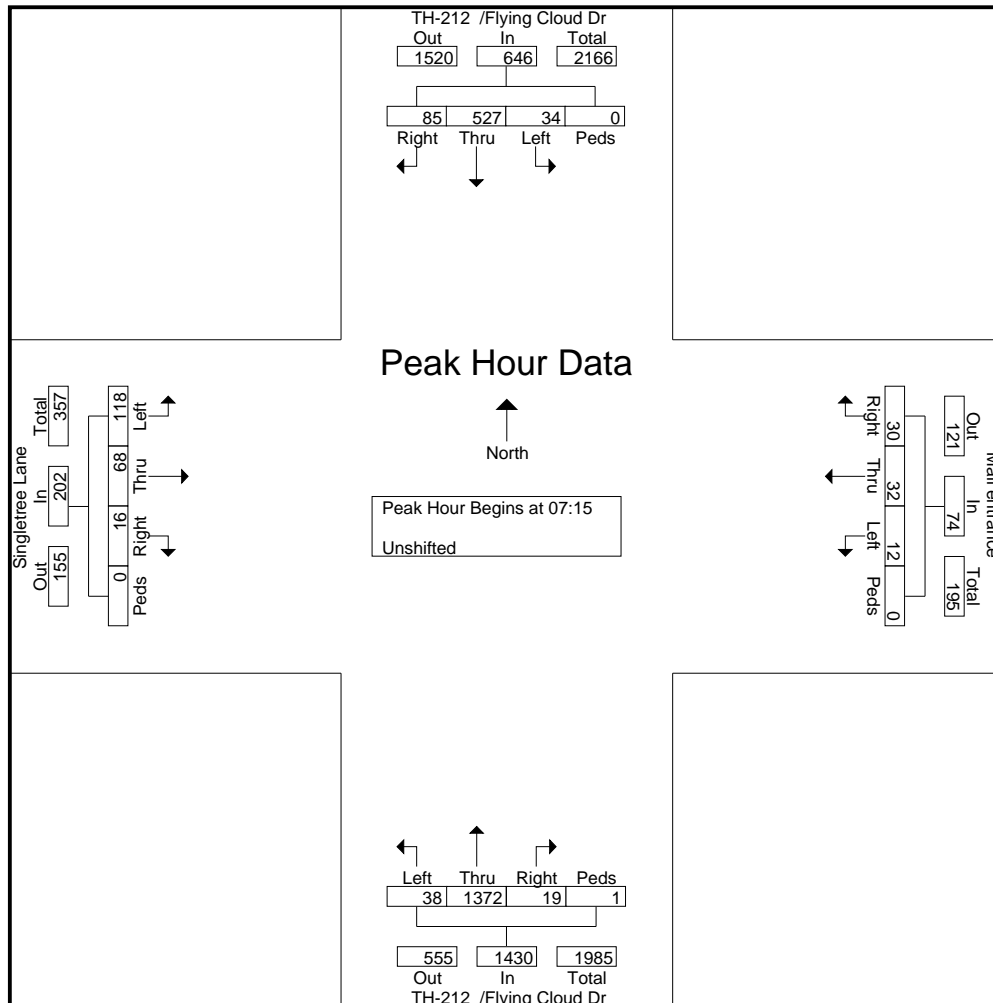

Albeck Gerken, Inc

Transportation Engineers

Traffic Data Collection

TH-212 at Singletree Lane

Ref.Pt.: 158.996

Data by: Albeck Gerken Inc -Radomir/Sue

TURN MOVEMENT COUNT

File Name : TH-212 at Singletree Lane 2004

Site Code : 00000000

Start Date : 12/14/2004

Page No : 3

Start Time	TH-212 /Flying Cloud Dr Southbound					Mall entrance Westbound					TH-212 /Flying Cloud Dr Northbound					Singletree Lane Eastbound					Int. Total
	Left	Thru	Right	Peds	App. Total	Left	Thru	Right	Peds	App. Total	Left	Thru	Right	Peds	App. Total	Left	Thru	Right	Peds	App. Total	
Peak Hour Analysis From 16:00 to 17:45 - Peak 1 of 1																					
Peak Hour for Entire Intersection Begins at 17:00																					
17:00	47	319	67	0	433	37	71	12	0	120	15	177	19	0	211	50	67	24	0	141	905
17:15	54	301	51	0	406	26	61	12	0	99	28	174	17	0	219	42	63	22	0	127	851
17:30	36	314	55	0	405	32	61	28	0	121	22	164	21	0	207	43	76	37	1	157	890
17:45	30	291	36	0	357	31	56	16	0	103	28	184	13	0	225	73	84	25	0	182	867
Total Volume	167	1225	209	0	1601	126	249	68	0	443	93	699	70	0	862	208	290	108	1	607	3513
% App. Total	10.4	76.5	13.1	0		28.4	56.2	15.3	0		10.8	81.1	8.1	0		34.3	47.8	17.8	0.2		
PHF	.773	.960	.780	.000	.924	.851	.877	.607	.000	.915	.830	.950	.833	.000	.958	.712	.863	.730	.250	.834	.970

