



# MINNESOTA DEPT OF TRANSPORTATION

## TRAFFIC DATA COLLECTION - METRO

TH-3 at 170th St W / Co.Rd.58  
 Ref.Pt.: 030.342  
 JAMAR # T-2638 CAH  
 TURN MOVEMENT COUNT

File Name : TH-3 at 170th St CoRd-58 2010  
 Site Code : 00000000  
 Start Date : 10/19/2010  
 Page No : 1

### Groups Printed- Cars & Trucks

| Start Time    | TH-3 Southbound |      |       |      | 170th St W / Co.Rd.58 Westbound |      |       |      | TH-3 Northbound |      |       |      | 170th St W / Co.Rd.58 Eastbound |      |       |      | Int. Total |
|---------------|-----------------|------|-------|------|---------------------------------|------|-------|------|-----------------|------|-------|------|---------------------------------|------|-------|------|------------|
|               | Left            | Thru | Right | Peds | Left                            | Thru | Right | Peds | Left            | Thru | Right | Peds | Left                            | Thru | Right | Peds |            |
| 06:00         | 2               | 15   | 3     | 0    | 0                               | 2    | 0     | 0    | 17              | 99   | 3     | 0    | 11                              | 1    | 4     | 0    | 157        |
| 06:15         | 6               | 27   | 5     | 0    | 0                               | 2    | 1     | 0    | 17              | 120  | 3     | 0    | 7                               | 3    | 1     | 0    | 192        |
| 06:30         | 3               | 39   | 7     | 0    | 0                               | 2    | 6     | 0    | 24              | 163  | 2     | 0    | 17                              | 1    | 5     | 0    | 269        |
| 06:45         | 1               | 35   | 8     | 0    | 2                               | 0    | 2     | 0    | 28              | 130  | 1     | 0    | 14                              | 1    | 5     | 0    | 227        |
| Total         | 12              | 116  | 23    | 0    | 2                               | 6    | 9     | 0    | 86              | 512  | 9     | 0    | 49                              | 6    | 15    | 0    | 845        |
| 07:00         | 4               | 50   | 3     | 0    | 2                               | 2    | 13    | 0    | 26              | 160  | 2     | 0    | 18                              | 2    | 5     | 0    | 287        |
| 07:15         | 4               | 52   | 9     | 0    | 1                               | 1    | 9     | 0    | 25              | 170  | 0     | 0    | 17                              | 2    | 15    | 0    | 305        |
| 07:30         | 9               | 64   | 9     | 0    | 1                               | 0    | 3     | 0    | 29              | 200  | 5     | 0    | 22                              | 6    | 8     | 1    | 357        |
| 07:45         | 2               | 66   | 6     | 0    | 0                               | 1    | 5     | 0    | 25              | 140  | 4     | 0    | 24                              | 1    | 4     | 0    | 278        |
| Total         | 19              | 232  | 27    | 0    | 4                               | 4    | 30    | 0    | 105             | 670  | 11    | 0    | 81                              | 11   | 32    | 1    | 1227       |
| 08:00         | 1               | 50   | 6     | 0    | 1                               | 4    | 6     | 0    | 20              | 105  | 0     | 0    | 16                              | 0    | 6     | 0    | 215        |
| 08:15         | 6               | 48   | 8     | 0    | 2                               | 3    | 2     | 0    | 18              | 105  | 0     | 0    | 16                              | 2    | 7     | 0    | 217        |
| 08:30         | 11              | 36   | 6     | 0    | 2                               | 0    | 5     | 0    | 14              | 94   | 2     | 0    | 17                              | 1    | 6     | 0    | 194        |
| 08:45         | 2               | 45   | 6     | 0    | 1                               | 1    | 9     | 0    | 17              | 77   | 3     | 0    | 8                               | 1    | 6     | 0    | 176        |
| Total         | 20              | 179  | 26    | 0    | 6                               | 8    | 22    | 0    | 69              | 381  | 5     | 0    | 57                              | 4    | 25    | 0    | 802        |
| *** BREAK *** |                 |      |       |      |                                 |      |       |      |                 |      |       |      |                                 |      |       |      |            |
| 15:00         | 5               | 72   | 16    | 0    | 4                               | 2    | 3     | 0    | 10              | 43   | 3     | 0    | 10                              | 4    | 21    | 0    | 193        |
| 15:15         | 2               | 108  | 18    | 0    | 7                               | 1    | 5     | 0    | 6               | 61   | 1     | 0    | 10                              | 0    | 10    | 0    | 229        |
| 15:30         | 4               | 78   | 11    | 0    | 2                               | 2    | 3     | 0    | 12              | 79   | 0     | 0    | 11                              | 2    | 19    | 0    | 223        |
| 15:45         | 2               | 104  | 13    | 0    | 2                               | 3    | 3     | 0    | 16              | 64   | 0     | 0    | 7                               | 0    | 11    | 0    | 225        |
| Total         | 13              | 362  | 58    | 0    | 15                              | 8    | 14    | 0    | 44              | 247  | 4     | 0    | 38                              | 6    | 61    | 0    | 870        |
| 16:00         | 4               | 117  | 22    | 1    | 2                               | 5    | 1     | 0    | 14              | 65   | 3     | 0    | 5                               | 2    | 34    | 0    | 275        |
| 16:15         | 5               | 159  | 25    | 0    | 5                               | 2    | 4     | 1    | 18              | 81   | 5     | 0    | 5                               | 2    | 24    | 0    | 336        |
| 16:30         | 2               | 149  | 25    | 0    | 4                               | 3    | 2     | 0    | 21              | 71   | 1     | 0    | 14                              | 1    | 25    | 0    | 318        |
| 16:45         | 2               | 145  | 32    | 0    | 2                               | 1    | 1     | 0    | 14              | 85   | 4     | 0    | 8                               | 2    | 32    | 0    | 328        |
| Total         | 13              | 570  | 104   | 1    | 13                              | 11   | 8     | 1    | 67              | 302  | 13    | 0    | 32                              | 7    | 115   | 0    | 1257       |
| 17:00         | 2               | 121  | 35    | 0    | 5                               | 1    | 3     | 0    | 21              | 72   | 0     | 0    | 17                              | 2    | 21    | 0    | 300        |
| 17:15         | 0               | 120  | 38    | 0    | 0                               | 0    | 3     | 0    | 22              | 82   | 0     | 0    | 12                              | 0    | 23    | 0    | 300        |
| 17:30         | 6               | 128  | 28    | 0    | 1                               | 1    | 3     | 0    | 14              | 77   | 1     | 0    | 13                              | 0    | 26    | 0    | 298        |
| 17:45         | 4               | 136  | 20    | 0    | 2                               | 2    | 2     | 0    | 17              | 67   | 0     | 0    | 11                              | 4    | 22    | 0    | 287        |
| Total         | 12              | 505  | 121   | 0    | 8                               | 4    | 11    | 0    | 74              | 298  | 1     | 0    | 53                              | 6    | 92    | 0    | 1185       |
| Grand Total   | 89              | 1964 | 359   | 1    | 48                              | 41   | 94    | 1    | 445             | 2410 | 43    | 0    | 310                             | 40   | 340   | 1    | 6186       |
| Apprch %      | 3.7             | 81.4 | 14.9  | 0    | 26.1                            | 22.3 | 51.1  | 0.5  | 15.4            | 83.2 | 1.5   | 0    | 44.9                            | 5.8  | 49.2  | 0.1  |            |
| Total %       | 1.4             | 31.7 | 5.8   | 0    | 0.8                             | 0.7  | 1.5   | 0    | 7.2             | 39   | 0.7   | 0    | 5                               | 0.6  | 5.5   | 0    |            |



# MINNESOTA DEPT OF TRANSPORTATION

## TRAFFIC DATA COLLECTION - METRO

TH-3 at 170th St W / Co.Rd.58  
 Ref.Pt.: 030.342  
 JAMAR # T-2638 CAH  
 TURN MOVEMENT COUNT

File Name : TH-3 at 170th St CoRd-58 2010  
 Site Code : 00000000  
 Start Date : 10/19/2010  
 Page No : 2

| Start Time   | TH-3 Southbound |      |       |      |            | 170th St W / Co.Rd.58 Westbound |      |       |      |            | TH-3 Northbound |      |       |      |            | 170th St W / Co.Rd.58 Eastbound |      |       |      |            | Int. Total |
|--|-----------------|------|-------|------|------------|---------------------------------|------|-------|------|------------|-----------------|------|-------|------|------------|---------------------------------|------|-------|------|------------|------------|
|  | Left            | Thru | Right | Peds | App. Total | Left                            | Thru | Right | Peds | App. Total | Left            | Thru | Right | Peds | App. Total | Left                            | Thru | Right | Peds | App. Total |            |
| Peak Hour Analysis From 06:00 to 08:45 - Peak 1 of 1 |                 |      |       |      |            |                                 |      |       |      |            |                 |      |       |      |            |                                 |      |       |      |            |            |
| Peak Hour for Entire Intersection Begins at 07:00    |                 |      |       |      |            |                                 |      |       |      |            |                 |      |       |      |            |                                 |      |       |      |            |            |
| 07:00  | 4               | 50   | 3     | 0    | 57         | 2                               | 2    | 13    | 0    | 17         | 26              | 160  | 2     | 0    | 188        | 18                              | 2    | 5     | 0    | 25         | 287        |
| 07:15  | 4               | 52   | 9     | 0    | 65         | 1                               | 1    | 9     | 0    | 11         | 25              | 170  | 0     | 0    | 195        | 17                              | 2    | 15    | 0    | 34         | 305        |
| 07:30  | 9               | 64   | 9     | 0    | 82         | 1                               | 0    | 3     | 0    | 4          | 29              | 200  | 5     | 0    | 234        | 22                              | 6    | 8     | 1    | 37         | 357        |
| 07:45  | 2               | 66   | 6     | 0    | 74         | 0                               | 1    | 5     | 0    | 6          | 25              | 140  | 4     | 0    | 169        | 24                              | 1    | 4     | 0    | 29         | 278        |
| Total Volume   | 19              | 232  | 27    | 0    | 278        | 4                               | 4    | 30    | 0    | 38         | 105             | 670  | 11    | 0    | 786        | 81                              | 11   | 32    | 1    | 125        | 1227       |
| % App. Total   | 6.8             | 83.5 | 9.7   | 0    |            | 10.5                            | 10.5 | 78.9  | 0    |            | 13.4            | 85.2 | 1.4   | 0    |            | 64.8                            | 8.8  | 25.6  | 0.8  |            |            |
| PHF  | .528            | .879 | .750  | .000 | .848       | .500                            | .500 | .577  | .000 | .559       | .905            | .838 | .550  | .000 | .840       | .844                            | .458 | .533  | .250 | .845       | .859       |

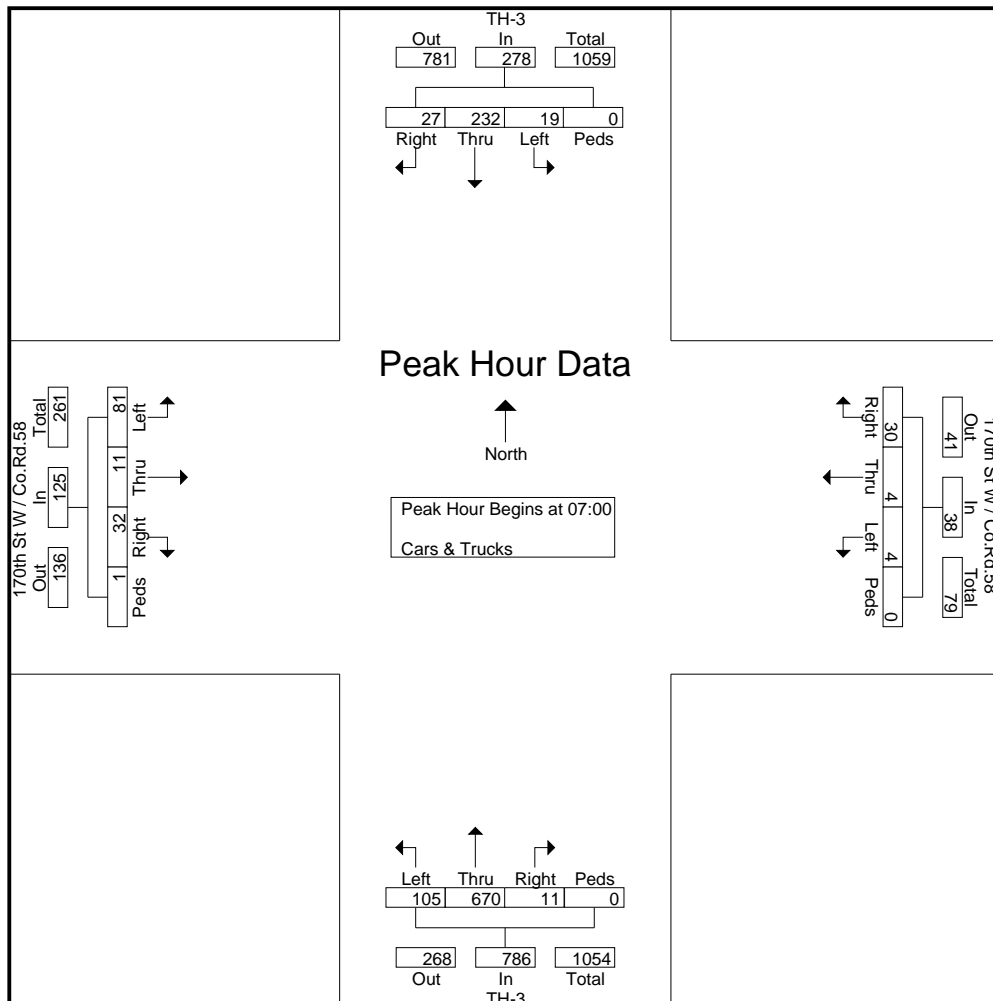



# MINNESOTA DEPT OF TRANSPORTATION

## TRAFFIC DATA COLLECTION - METRO

TH-3 at 170th St W / Co.Rd.58  
 Ref.Pt.: 030.342  
 JAMAR # T-2638 CAH  
 TURN MOVEMENT COUNT

File Name : TH-3 at 170th St CoRd-58 2010  
 Site Code : 00000000  
 Start Date : 10/19/2010  
 Page No : 3

| Start Time   | TH-3 Southbound |      |       |      |            | 170th St W / Co.Rd.58 Westbound |      |       |      |            | TH-3 Northbound |      |       |      |            | 170th St W / Co.Rd.58 Eastbound |      |       |      |            | Int. Total |
|--------------|-----------------|------|-------|------|------------|---------------------------------|------|-------|------|------------|-----------------|------|-------|------|------------|---------------------------------|------|-------|------|------------|------------|
|              | Left            | Thru | Right | Peds | App. Total | Left                            | Thru | Right | Peds | App. Total | Left            | Thru | Right | Peds | App. Total | Left                            | Thru | Right | Peds | App. Total |            |
| 16:15        | 5               | 159  | 25    | 0    | 189        | 5                               | 2    | 4     | 1    | 12         | 18              | 81   | 5     | 0    | 104        | 5                               | 2    | 24    | 0    | 31         | 336        |
| 16:30        | 2               | 149  | 25    | 0    | 176        | 4                               | 3    | 2     | 0    | 9          | 21              | 71   | 1     | 0    | 93         | 14                              | 1    | 25    | 0    | 40         | 318        |
| 16:45        | 2               | 145  | 32    | 0    | 179        | 2                               | 1    | 1     | 0    | 4          | 14              | 85   | 4     | 0    | 103        | 8                               | 2    | 32    | 0    | 42         | 328        |
| 17:00        | 2               | 121  | 35    | 0    | 158        | 5                               | 1    | 3     | 0    | 9          | 21              | 72   | 0     | 0    | 93         | 17                              | 2    | 21    | 0    | 40         | 300        |
| Total Volume | 11              | 574  | 117   | 0    | 702        | 16                              | 7    | 10    | 1    | 34         | 74              | 309  | 10    | 0    | 393        | 44                              | 7    | 102   | 0    | 153        | 1282       |
| % App. Total | 1.6             | 81.8 | 16.7  | 0    |            | 47.1                            | 20.6 | 29.4  | 2.9  |            | 18.8            | 78.6 | 2.5   | 0    |            | 28.8                            | 4.6  | 66.7  | 0    |            |            |
| PHF          | .550            | .903 | .836  | .000 | .929       | .800                            | .583 | .625  | .250 | .708       | .881            | .909 | .500  | .000 | .945       | .647                            | .875 | .797  | .000 | .911       | .954       |

Peak Hour Analysis From 15:00 to 17:45 - Peak 1 of 1  
 Peak Hour for Entire Intersection Begins at 16:15

