



# Minnesota Dept. of Transportation

## Traffic Data Collection -Metro

TH-3 / S ROBERT TR AT 60TH ST W  
 Ref.Pt; 042.682  
 Jamar # T-2638 CAH  
 TURN MOVEMENT COUNT

File Name : TH-3 -S ROBERT TR AT 60TH ST W 2012  
 Site Code : 042.682  
 Start Date : 4/4/2012  
 Page No : 1

**Groups Printed- Unshifted**

Start Time	TH-3 / S ROBERT TR Southbound				60TH ST W Westbound				TH-3 / S ROBERT TR Northbound				60TH ST W Eastbound				Int. Total
	Right	Thru	Left	Peds	Right	Thru	Left	Peds	Right	Thru	Left	Peds	Right	Thru	Left	Peds	
06:00	1	23	0	0	0	0	0	0	0	17	1	0	0	0	2	0	44
06:15	0	15	0	0	0	0	0	0	0	13	1	0	0	0	0	0	29
06:30	1	15	0	0	0	0	0	0	0	12	0	0	0	0	2	0	30
06:45	0	10	0	0	0	0	0	0	0	16	0	0	0	0	1	0	27
Total	2	63	0	0	0	0	0	0	0	58	2	0	0	0	5	0	130
07:00	0	0	0	0	0	0	0	0	0	5	0	0	1	0	1	0	7
07:15	0	36	0	0	0	0	0	0	0	87	0	0	0	0	1	0	124
07:30	1	56	0	0	0	0	0	0	0	81	0	0	0	0	1	0	139
07:45	0	61	0	0	0	0	0	0	0	82	0	0	0	0	2	0	145
Total	1	153	0	0	0	0	0	0	0	255	0	0	1	0	5	0	415
08:00	1	45	0	0	0	0	0	0	0	51	1	0	0	0	2	0	100
08:15	2	27	0	0	0	0	0	0	0	54	0	0	0	0	1	0	84
08:30	0	35	0	0	0	0	0	0	0	48	0	0	0	0	3	0	86
08:45	2	38	0	0	0	0	0	0	0	44	0	0	1	0	0	0	85
Total	5	145	0	0	0	0	0	0	0	197	1	0	1	0	6	0	355
*** BREAK ***																	
15:00	0	70	0	0	0	0	0	0	0	53	1	0	0	0	0	0	124
15:15	1	52	0	0	0	0	0	0	0	60	0	0	0	0	0	0	113
15:30	2	72	0	0	0	0	0	0	0	53	0	0	0	0	1	0	128
15:45	0	71	0	0	0	0	0	0	0	59	0	0	0	0	1	0	131
Total	3	265	0	0	0	0	0	0	0	225	1	0	0	0	2	0	496
16:00	0	74	0	0	0	0	0	0	0	46	0	0	0	0	0	0	120
16:15	2	80	0	0	0	0	0	0	0	54	2	0	0	0	1	0	139
16:30	0	101	0	0	0	0	0	0	0	58	2	0	0	0	0	0	161
16:45	3	86	0	0	0	0	0	0	0	55	0	0	0	0	1	0	145
Total	5	341	0	0	0	0	0	0	0	213	4	0	0	0	2	0	565
17:00	3	88	0	0	0	0	0	0	0	55	0	0	0	0	0	0	146
17:15	4	77	0	0	0	0	0	0	0	72	1	0	2	0	2	0	158
17:30	2	75	0	0	0	0	0	0	0	56	1	0	1	0	1	0	136
17:45	2	73	0	0	0	0	0	0	0	49	0	0	0	0	2	0	126
Total	11	313	0	0	0	0	0	0	0	232	2	0	3	0	5	0	566
Grand Total	27	1280	0	0	0	0	0	0	0	1180	10	0	5	0	25	0	2527
Apprch %	2.1	97.9	0	0	0	0	0	0	0	99.2	0.8	0	16.7	0	83.3	0	
Total %	1.1	50.7	0	0	0	0	0	0	0	46.7	0.4	0	0.2	0	1	0	



# Minnesota Dept. of Transportation

## Traffic Data Collection -Metro

TH-3 / S ROBERT TR AT 60TH ST W  
 Ref.Pt; 042.682  
 Jamar # T-2638 CAH  
 TURN MOVEMENT COUNT

File Name : TH-3 -S ROBERT TR AT 60TH ST W 2012  
 Site Code : 042.682  
 Start Date : 4/4/2012  
 Page No : 2

Start Time	TH-3 / S ROBERT TR Southbound					60TH ST W Westbound					TH-3 / S ROBERT TR Northbound					60TH ST W Eastbound					Int. Total
	Right	Thru	Left	Peds	App. Total	Right	Thru	Left	Peds	App. Total	Right	Thru	Left	Peds	App. Total	Right	Thru	Left	Peds	App. Total	
Peak Hour Analysis From 06:00 to 08:45 - Peak 1 of 1																					
Peak Hour for Entire Intersection Begins at 07:15																					
07:15	0	36	0	0	36	0	0	0	0	0	0	87	0	0	87	0	0	1	0	1	124
07:30	1	56	0	0	57	0	0	0	0	0	0	81	0	0	81	0	0	1	0	1	139
07:45	0	61	0	0	61	0	0	0	0	0	0	82	0	0	82	0	0	2	0	2	145
08:00	1	45	0	0	46	0	0	0	0	0	0	51	1	0	52	0	0	2	0	2	100
Total Volume	2	198	0	0	200	0	0	0	0	0	0	301	1	0	302	0	0	6	0	6	508
% App. Total	1	99	0	0		0	0	0	0		0	99.7	0.3	0		0	0	100	0		
PHF	.500	.811	.000	.000	.820	.000	.000	.000	.000	.000	.000	.865	.250	.000	.868	.000	.000	.750	.000	.750	.876

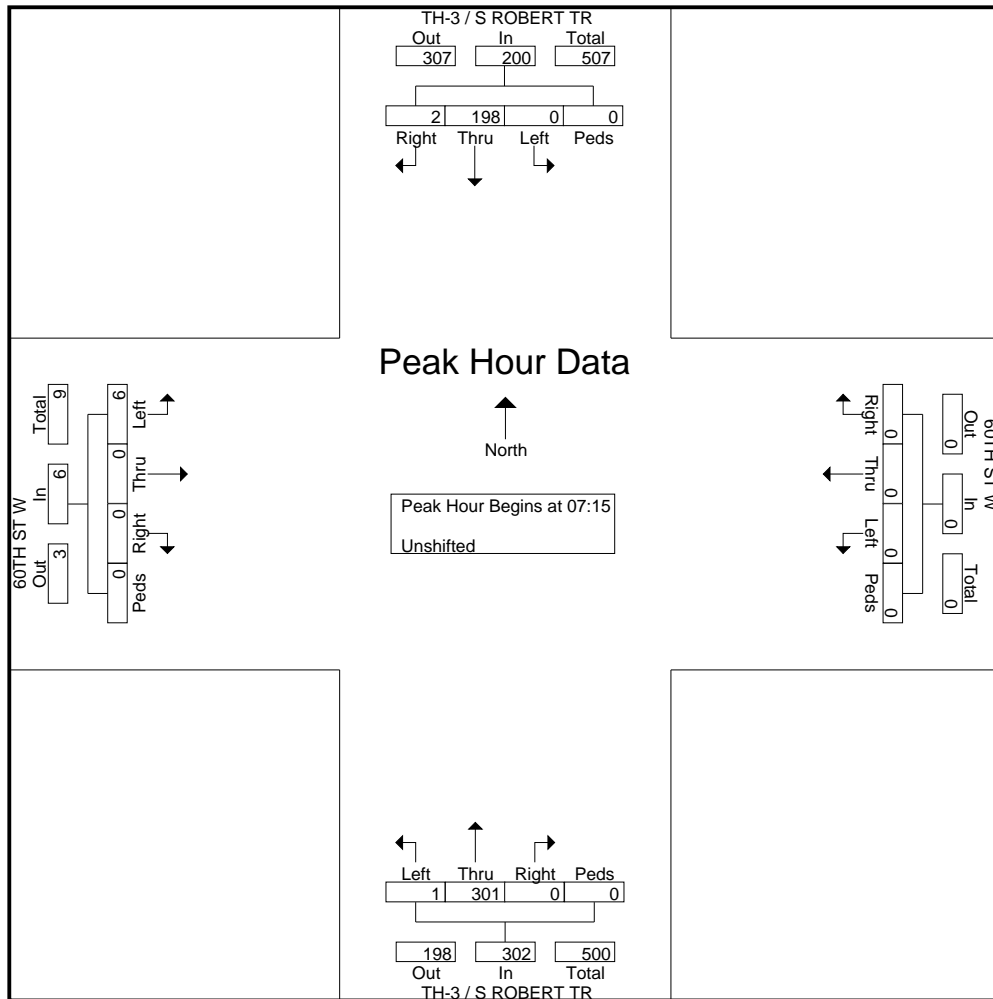



# Minnesota Dept. of Transportation

## Traffic Data Collection -Metro

TH-3 / S ROBERT TR AT 60TH ST W  
 Ref.Pt; 042.682  
 Jamar # T-2638 CAH  
 TURN MOVEMENT COUNT

File Name : TH-3 -S ROBERT TR AT 60TH ST W 2012  
 Site Code : 042.682  
 Start Date : 4/4/2012  
 Page No : 3

Start Time	TH-3 / S ROBERT TR Southbound					60TH ST W Westbound					TH-3 / S ROBERT TR Northbound					60TH ST W Eastbound					Int. Total
	Rig ht	Thr u	Left	Ped s	App. Total	Rig ht	Thr u	Left	Ped s	App. Total	Right	Thr u	Left	Peds	App. Total	Right	Thr u	Left	Peds	App. Total	
Peak Hour Analysis From 15:00 to 17:45 - Peak 1 of 1																					
Peak Hour for Entire Intersection Begins at 16:30																					
16:30	0	101	0	0	101	0	0	0	0	0	0	58	2	0	60	0	0	0	0	0	161
16:45	3	86	0	0	89	0	0	0	0	0	0	55	0	0	55	0	0	1	0	1	145
17:00	3	88	0	0	91	0	0	0	0	0	0	55	0	0	55	0	0	0	0	0	146
17:15	4	77	0	0	81	0	0	0	0	0	0	72	1	0	73	2	0	2	0	4	158
Total Volume	10	352	0	0	362	0	0	0	0	0	0	240	3	0	243	2	0	3	0	5	610
% App. Total	2.8	97.2	0	0		0	0	0	0		0	98.8	1.2	0		40	0	60	0		
PHF	.625	.871	.000	.000	.896	.000	.000	.000	.000	.000	.000	.833	.375	.000	.832	.250	.000	.375	.000	.313	.947

