



MINNESOTA DEPT OF TRANSPORTATION

TRAFFIC DATA COLLECTION - METRO

Lexington Ave at Co.Rd.B2
 Ref.Pt.:
 JAMAR # 631 RE
 TURN MOVEMENT COUNT

File Name : Lexington Ave at CoRd B2 2010
 Site Code : 00000000
 Start Date : 2/24/2010
 Page No : 1

Groups Printed- Cars & Trucks

Start Time	Lexington Ave Southbound				Co.Rd. B2 Westbound				Lexington Ave Northbound				Co.Rd. B2 Eastbound				Int. Total
	Left	Thru	Right	Peds	Left	Thru	Right	Peds	Left	Thru	Right	Peds	Left	Thru	Right	Peds	
06:00	0	33	0	0	3	5	0	0	6	17	0	0	0	2	0	0	66
06:15	0	53	3	0	10	11	3	0	8	13	0	0	0	1	5	0	107
06:30	1	80	5	0	17	12	4	0	13	30	1	0	1	5	5	0	174
06:45	0	78	19	0	11	36	3	0	23	43	3	0	4	19	10	0	249
Total	1	244	27	0	41	64	10	0	50	103	4	0	5	27	20	0	596
07:00	4	110	19	0	17	52	7	0	35	55	5	0	4	24	22	0	354
07:15	7	114	30	0	16	52	6	0	32	70	3	0	5	7	23	0	365
07:30	6	138	37	0	15	82	5	0	46	72	6	0	9	31	48	0	495
07:45	5	137	49	0	11	75	14	0	53	107	7	0	17	38	75	0	588
Total	22	499	135	0	59	261	32	0	166	304	21	0	35	100	168	0	1802
08:00	4	99	21	0	11	32	5	0	29	79	3	0	11	30	49	0	373
08:15	6	99	5	0	11	23	8	0	19	64	3	0	2	11	9	0	260
08:30	1	113	9	0	11	12	3	0	12	75	2	0	1	9	4	0	252
08:45	2	92	9	0	14	22	2	0	11	82	5	0	4	6	9	0	258
Total	13	403	44	0	47	89	18	0	71	300	13	0	18	56	71	0	1143
*** BREAK ***																	
14:30	4	98	22	0	7	22	4	0	17	83	9	0	6	34	29	0	335
14:45	3	86	10	0	5	25	5	0	26	80	7	0	21	72	92	0	432
Total	7	184	32	0	12	47	9	0	43	163	16	0	27	106	121	0	767
15:00	3	86	11	0	5	19	1	0	20	86	12	0	20	58	35	0	356
15:15	4	97	5	0	11	29	7	0	24	103	13	0	9	34	29	0	365
15:30	6	105	11	0	11	16	5	0	19	120	14	0	14	45	30	0	396
15:45	8	93	8	0	5	20	4	0	22	131	17	1	11	41	37	0	398
Total	21	381	35	0	32	84	17	0	85	440	56	1	54	178	131	0	1515
16:00	4	100	7	0	3	24	6	0	15	117	11	0	19	67	35	0	408
16:15	6	88	9	0	5	20	8	0	20	155	14	0	14	56	38	0	433
16:30	4	107	12	0	10	8	11	0	28	171	16	0	13	63	30	0	473
16:45	11	119	13	0	8	22	6	0	26	168	18	0	12	72	28	0	503
Total	25	414	41	0	26	74	31	0	89	611	59	0	58	258	131	0	1817
17:00	9	121	10	0	12	19	8	0	35	182	19	0	19	74	42	0	550
17:15	11	122	15	0	6	24	3	0	22	172	15	0	12	59	38	0	499
17:30	7	107	14	0	6	31	8	0	36	150	17	0	10	69	44	0	499
17:45	6	91	8	0	6	28	10	0	24	129	9	0	11	41	29	0	392
Total	33	441	47	0	30	102	29	0	117	633	60	0	52	243	153	0	1940
Grand Total	122	2566	361	0	247	721	146	0	621	2554	229	1	249	968	795	0	9580
Apprch %	4	84.2	11.8	0	22.2	64.7	13.1	0	18.2	75	6.7	0	12.4	48.1	39.5	0	
Total %	1.3	26.8	3.8	0	2.6	7.5	1.5	0	6.5	26.7	2.4	0	2.6	10.1	8.3	0	

Co.Rd. B2 - Many vehicles used the Right Turn Lane as a "Bypass Lane" to move around a vehicle stopped to make a left turn. This was both EB & WB.

Signed - Right lane must make Right Turn.



MINNESOTA DEPT OF TRANSPORTATION

TRAFFIC DATA COLLECTION - METRO

Lexington Ave at Co.Rd.B2
 Ref.Pt.:
 JAMAR # 631 RE
 TURN MOVEMENT COUNT

File Name : Lexington Ave at CoRd B2 2010
 Site Code : 00000000
 Start Date : 2/24/2010
 Page No : 2

Start Time	Lexington Ave Southbound					Co.Rd. B2 Westbound					Lexington Ave Northbound					Co.Rd. B2 Eastbound					Int. Total
	Left	Thru	Right	Peds	App. Total	Left	Thru	Right	Peds	App. Total	Left	Thru	Right	Peds	App. Total	Left	Thru	Right	Peds	App. Total	
Peak Hour Analysis From 06:00 to 08:45 - Peak 1 of 1																					
Peak Hour for Entire Intersection Begins at 07:15																					
07:15	7	114	30	0	151	16	52	6	0	74	32	70	3	0	105	5	7	23	0	35	365
07:30	6	138	37	0	181	15	82	5	0	102	46	72	6	0	124	9	31	48	0	88	495
07:45	5	137	49	0	191	11	75	14	0	100	53	107	7	0	167	17	38	75	0	130	588
08:00	4	99	21	0	124	11	32	5	0	48	29	79	3	0	111	11	30	49	0	90	373
Total Volume	22	488	137	0	647	53	241	30	0	324	160	328	19	0	507	42	106	195	0	343	1821
% App. Total	3.4	75.4	21.2	0		16.4	74.4	9.3	0		31.6	64.7	3.7	0		12.2	30.9	56.9	0		
PHF	.786	.884	.699	.000	.847	.828	.735	.536	.000	.794	.755	.766	.679	.000	.759	.618	.697	.650	.000	.660	.774

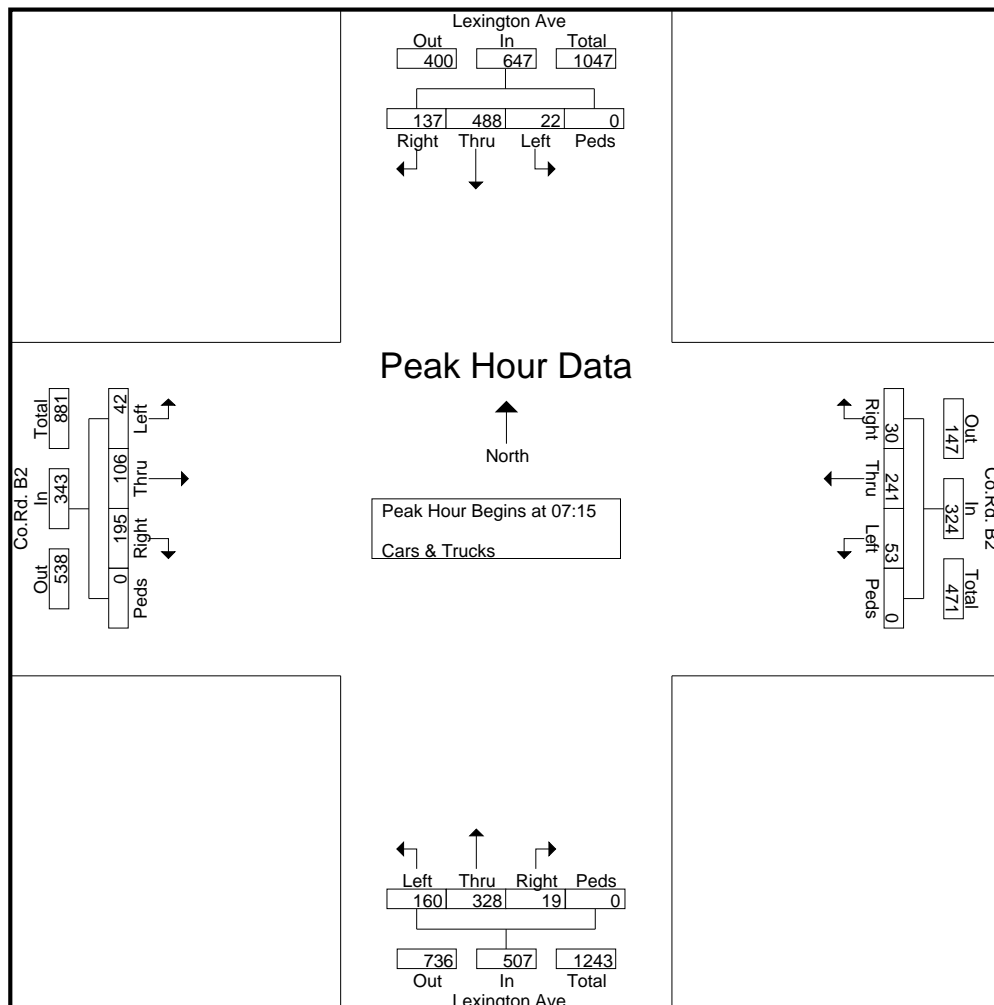



MINNESOTA DEPT OF TRANSPORTATION

TRAFFIC DATA COLLECTION - METRO

Lexington Ave at Co.Rd.B2
 Ref.Pt.:
 JAMAR # 631 RE
 TURN MOVEMENT COUNT

File Name : Lexington Ave at CoRd B2 2010
 Site Code : 00000000
 Start Date : 2/24/2010
 Page No : 3

Start Time	Lexington Ave Southbound					Co.Rd. B2 Westbound					Lexington Ave Northbound					Co.Rd. B2 Eastbound					Int. Total
	Left	Thru	Right	Peds	App. Total	Left	Thru	Right	Peds	App. Total	Left	Thru	Right	Peds	App. Total	Left	Thru	Right	Peds	App. Total	

Peak Hour Analysis From 14:30 to 17:45 - Peak 1 of 1

Peak Hour for Entire Intersection Begins at 16:45

16:45	11	119	13	0	143	8	22	6	0	36	26	168	18	0	212	12	72	28	0	112	503
17:00	9	121	10	0	140	12	19	8	0	39	35	182	19	0	236	19	74	42	0	135	550
17:15	11	122	15	0	148	6	24	3	0	33	22	172	15	0	209	12	59	38	0	109	499
17:30	7	107	14	0	128	6	31	8	0	45	36	150	17	0	203	10	69	44	0	123	499
Total Volume	38	469	52	0	559	32	96	25	0	153	119	672	69	0	860	53	274	152	0	479	2051
% App. Total	6.8	83.9	9.3	0		20.9	62.7	16.3	0		13.8	78.1	8	0		11.1	57.2	31.7	0		
PHF	.864	.961	.867	.000	.944	.667	.774	.781	.000	.850	.826	.923	.908	.000	.911	.697	.926	.864	.000	.887	.932

