

# Associated Consulting Services (ACS)

Saint Paul, MN 55127

-- TRAFFIC DATA --

TH-36 at English St (S.ramp)\_2019

Ref Pt: 007+00.131

Data Prepared By: ACS

TURNING MOVEMENT COUNT

File Name : TH-36 at English St (S.ramp)\_2019

Site Code :

Start Date : 7/23/2019

Page No : 1

Groups Printed- Cars - Trucks

Start Time	English St Southbound				TH-36 EB on ramp Westbound				English St Northbound				TH-36 EB off ramp Eastbound				Int. Total
	Left	Thru	Right	Peds	Left	Thru	Right	Peds	Left	Thru	Right	Peds	Left	Thru	Right	Peds	
06:00	2	13	0	0	0	0	0	0	0	78	12	0	13	0	26	0	144
06:15	10	30	0	0	0	0	0	0	0	107	8	0	14	0	32	0	201
06:30	4	21	0	0	0	0	0	0	0	137	14	0	18	0	42	0	236
06:45	2	20	0	0	0	0	0	0	0	122	10	0	27	0	46	0	227
Total	18	84	0	0	0	0	0	0	0	444	44	0	72	0	146	0	808
07:00	2	22	0	0	0	0	0	0	0	120	19	0	13	0	41	1	218
07:15	2	37	0	0	0	0	0	0	0	126	16	0	14	1	55	2	253
07:30	3	35	0	0	0	0	0	0	0	122	21	0	23	0	65	0	269
07:45	4	41	0	0	0	0	0	0	0	104	18	0	17	0	59	0	243
Total	11	135	0	0	0	0	0	0	0	472	74	0	67	1	220	3	983
08:00	2	43	0	0	0	0	0	0	0	100	22	0	24	1	38	0	230
08:15	5	31	0	0	0	0	0	0	0	96	12	0	21	0	55	0	220
08:30	9	45	0	0	0	0	0	1	0	96	35	0	22	1	74	3	286
08:45	1	47	0	0	0	0	0	0	0	108	32	0	11	2	70	0	271
Total	17	166	0	0	0	0	0	1	0	400	101	0	78	4	237	3	1007
09:00	6	38	0	0	0	0	0	0	0	90	30	0	15	0	47	0	226
09:15	7	35	0	0	0	0	0	0	0	95	26	0	20	1	45	0	229
09:30	6	33	0	0	0	0	0	0	0	88	34	0	12	0	44	0	217
09:45	9	27	0	0	0	0	0	1	0	75	27	0	18	0	54	0	211
Total	28	133	0	0	0	0	0	1	0	348	117	0	65	1	190	0	883
10:00	3	35	0	0	0	0	0	0	0	72	24	0	15	0	50	0	199
10:15	3	26	0	0	0	0	0	0	0	81	19	0	17	1	51	0	198
10:30	8	34	0	0	0	0	0	0	0	83	22	0	7	1	52	0	207
10:45	4	42	0	0	0	0	0	0	0	83	30	0	18	0	58	1	236
Total	18	137	0	0	0	0	0	0	0	319	95	0	57	2	211	1	840
11:00	11	44	0	0	0	0	0	0	0	62	21	0	9	0	47	2	196
11:15	5	43	0	0	0	0	0	0	0	84	26	0	18	0	58	0	234
11:30	12	35	0	0	0	0	0	0	0	82	34	0	20	0	64	0	247
11:45	4	64	0	0	0	0	0	0	0	92	35	0	17	0	78	0	290
Total	32	186	0	0	0	0	0	0	0	320	116	0	64	0	247	2	967
12:00	8	49	0	0	0	0	0	0	0	105	45	0	11	0	64	0	282
12:15	6	39	0	0	0	0	0	0	0	83	45	0	27	0	78	0	278
12:30	4	42	0	0	0	0	0	0	0	100	34	0	8	0	40	0	228
12:45	5	43	0	0	0	0	0	1	0	80	32	0	20	0	67	0	248
Total	23	173	0	0	0	0	0	1	0	368	156	0	66	0	249	0	1036
13:00	9	39	0	0	0	0	0	0	0	106	43	0	27	0	63	0	287
13:15	7	47	0	0	0	0	0	0	0	92	34	0	22	0	87	0	289
13:30	9	44	0	0	0	0	0	0	0	125	37	0	19	1	65	2	302
13:45	5	53	0	0	0	0	0	0	0	102	28	0	19	0	56	1	264
Total	30	183	0	0	0	0	0	0	0	425	142	0	87	1	271	3	1142
14:00	11	51	0	0	0	0	0	0	0	115	27	0	23	0	64	0	291
14:15	5	42	0	0	0	0	0	1	0	97	28	0	20	0	78	0	271
14:30	12	54	0	0	0	0	0	0	0	121	40	0	19	1	70	0	317

# Associated Consulting Services (ACS)

Saint Paul, MN 55127

-- TRAFFIC DATA --

TH-36 at English St (S.ramp)\_2019

File Name : TH-36 at English St (S.ramp)\_2019

Ref Pt: 007+00.131

Site Code :

Data Prepared By: ACS

Start Date : 7/23/2019

TURNING MOVEMENT COUNT

Page No : 2

Groups Printed- Cars - Trucks

Start Time	English St Southbound				TH-36 EB on ramp Westbound				English St Northbound				TH-36 EB off ramp Eastbound				Int. Total
	Left	Thru	Right	Peds	Left	Thru	Right	Peds	Left	Thru	Right	Peds	Left	Thru	Right	Peds	
14:45	2	63	0	0	0	0	0	0	0	121	48	0	18	0	104	0	356
Total	30	210	0	0	0	0	0	1	0	454	143	0	80	1	316	0	1235
15:00	6	41	0	0	0	0	0	0	0	94	31	0	17	0	98	1	288
15:15	10	44	0	0	0	0	0	0	0	94	39	0	16	0	90	0	293
15:30	12	53	0	0	0	0	0	0	0	108	49	0	9	0	99	0	330
15:45	12	56	0	0	0	0	0	0	0	102	36	0	11	0	93	0	310
Total	40	194	0	0	0	0	0	0	0	398	155	0	53	0	380	1	1221
16:00	20	41	0	0	0	0	0	0	0	115	47	0	11	0	76	0	310
16:15	6	54	0	0	0	0	0	0	0	104	30	0	10	0	94	1	299
16:30	10	60	0	0	0	0	0	0	0	113	59	0	11	0	78	0	331
16:45	13	38	0	0	0	0	0	0	0	115	29	0	17	0	82	3	297
Total	49	193	0	0	0	0	0	0	0	447	165	0	49	0	330	4	1237
17:00	9	57	0	0	0	0	0	0	0	124	28	0	12	0	90	0	320
17:15	5	37	0	0	0	0	0	0	0	131	32	0	16	0	75	3	299
17:30	6	31	0	0	0	0	0	0	0	111	40	0	16	0	94	1	299
17:45	6	36	0	0	0	0	0	0	0	94	22	0	17	0	86	0	261
Total	26	161	0	0	0	0	0	0	0	460	122	0	61	0	345	4	1179
Grand Total	322	1955	0	0	0	0	0	4	0	4855	1430	0	799	10	3142	21	12538
Apprch %	14.1	85.9	0	0	0	0	0	100	0	77.2	22.8	0	20.1	0.3	79.1	0.5	
Total %	2.6	15.6	0	0	0	0	0	0	0	38.7	11.4	0	6.4	0.1	25.1	0.2	
Cars	281	1880	0	0	0	0	0	4	0	4732	1387	0	704	9	3047	21	12065
% Cars	87.3	96.2	0	0	0	0	0	100	0	97.5	97	0	88.1	90	97	100	96.2
Trucks	41	75	0	0	0	0	0	0	0	123	43	0	95	1	95	0	473
% Trucks	12.7	3.8	0	0	0	0	0	0	0	2.5	3	0	11.9	10	3	0	3.8

# Associated Consulting Services (ACS)

Saint Paul, MN 55127

-- TRAFFIC DATA --

TH-36 at English St (S.ramp)\_2019  
 Ref Pt: 007+00.131  
 Data Prepared By: ACS  
 TURNING MOVEMENT COUNT

File Name : TH-36 at English St (S.ramp)\_2019  
 Site Code :  
 Start Date : 7/23/2019  
 Page No : 3

Start Time	English St Southbound					TH-36 EB on ramp Westbound					English St Northbound					TH-36 EB off ramp Eastbound					Int. Total	
	Left	Thru	Right	Peds	App. Total	Left	Thru	Right	Peds	App. Total	Left	Thru	Right	Peds	App. Total	Left	Thru	Right	Peds	App. Total		
Peak Hour Analysis From 06:00 to 11:45 - Peak 1 of 1																						
Peak Hour for Entire Intersection Begins at 08:30																						
08:30	9	45	0	0	54	0	0	0	0	1	1	0	96	35	0	131	22	1	74	3	100	286
08:45	1	47	0	0	48	0	0	0	0	0	0	108	32	0	140	11	2	70	0	83	271	
09:00	6	38	0	0	44	0	0	0	0	0	0	90	30	0	120	15	0	47	0	62	226	
09:15	7	35	0	0	42	0	0	0	0	0	0	95	26	0	121	20	1	45	0	66	229	
Total Volume	23	165	0	0	188	0	0	0	1	1	0	389	123	0	512	68	4	236	3	311	1012	
% App. Total	12.2	87.8	0	0		0	0	0	100		0	76	24	0		21.9	1.3	75.9	1			
PHF	.639	.878	.000	.000	.870	.000	.000	.000	.250	.250	.000	.900	.879	.000	.914	.773	.500	.797	.250	.778	.885	

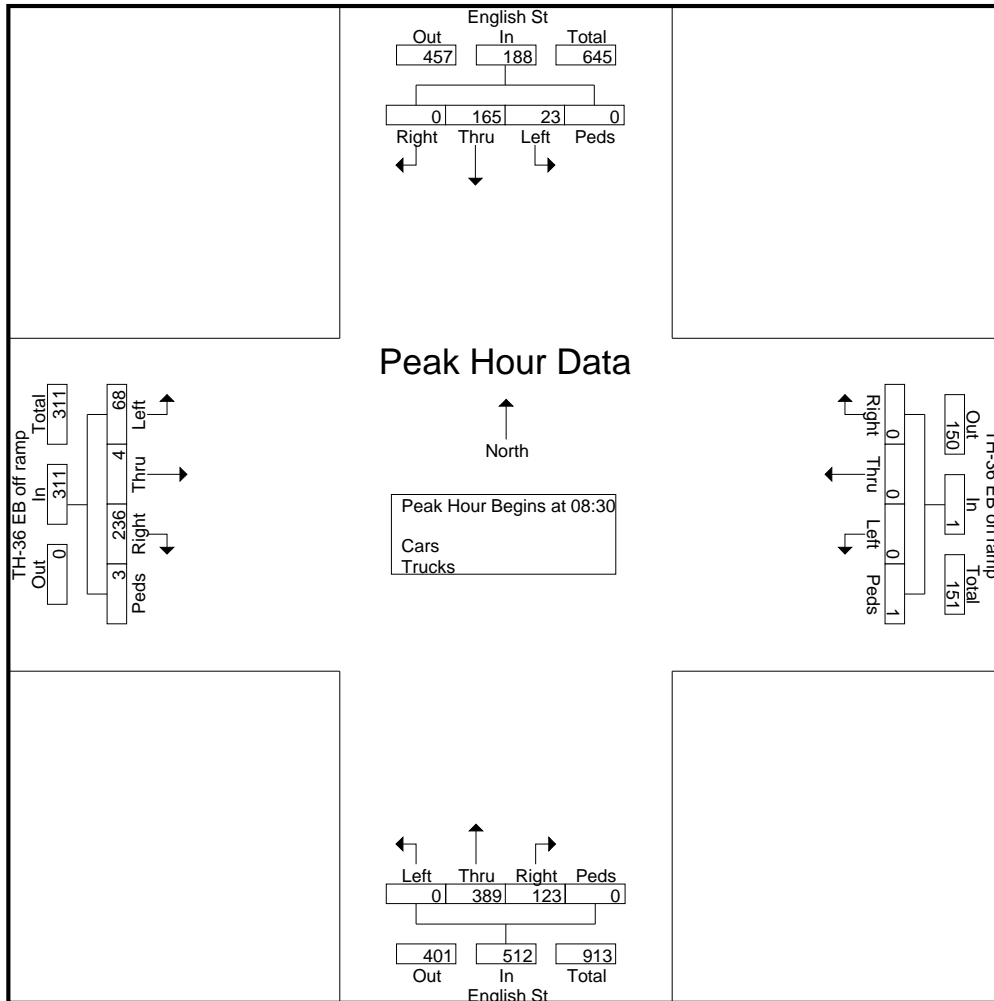

# Associated Consulting Services (ACS)

Saint Paul, MN 55127

-- TRAFFIC DATA --

TH-36 at English St (S.ramp)\_2019  
 Ref Pt: 007+00.131  
 Data Prepared By: ACS  
 TURNING MOVEMENT COUNT

File Name : TH-36 at English St (S.ramp)\_2019  
 Site Code :  
 Start Date : 7/23/2019  
 Page No : 4

Start Time	English St Southbound					TH-36 EB on ramp Westbound					English St Northbound					TH-36 EB off ramp Eastbound					Int. Total
	Left	Thru	Right	Peds	App. Total	Left	Thru	Right	Peds	App. Total	Left	Thru	Right	Peds	App. Total	Left	Thru	Right	Peds	App. Total	
Peak Hour Analysis From 12:00 to 17:45 - Peak 1 of 1																					
Peak Hour for Entire Intersection Begins at 14:45																					
14:45	2	63	0	0	65	0	0	0	0	0	0	121	48	0	169	18	0	104	0	122	356
15:00	6	41	0	0	47	0	0	0	0	0	0	94	31	0	125	17	0	98	1	116	288
15:15	10	44	0	0	54	0	0	0	0	0	0	94	39	0	133	16	0	90	0	106	293
15:30	12	53	0	0	65	0	0	0	0	0	0	108	49	0	157	9	0	99	0	108	330
Total Volume	30	201	0	0	231	0	0	0	0	0	0	417	167	0	584	60	0	391	1	452	1267
% App. Total	13	87	0	0		0	0	0	0		0	71.4	28.6	0		13.3	0	86.5	0.2		
PHF	.625	.798	.000	.000	.888	.000	.000	.000	.000	.000	.000	.862	.852	.000	.864	.833	.000	.940	.250	.926	.890

