



# MINNESOTA DEPT OF TRANSPORTATION

## TRAFFIC DATA COLLECTION - METRO

TH-41 at 3rd St., CHASKA  
 Ref.Pt.: 001.812  
 JAMAR # D4-3365 CH  
 TURN MOVEMENT COUNT

File Name : TH-41 at 3rd St CHASKA 2009  
 Site Code : 00000000  
 Start Date : 6/30/2009  
 Page No : 1

### Groups Printed- Cars & Trucks

Start Time	TH-41 / CHESTNUT ST Southbound				3RD ST. Westbound				TH-41 / CHESTNUT ST Northbound				3RD ST. Eastbound				Int. Total
	Left	Thru	Right	Peds	Left	Thru	Right	Peds	Left	Thru	Right	Peds	Left	Thru	Right	Peds	
06:00	1	94	0	0	0	0	2	0	0	83	0	0	0	0	0	0	180
06:15	0	87	1	0	0	0	1	0	1	99	1	0	2	0	3	0	195
06:30	0	133	2	0	2	0	4	0	0	134	5	0	0	0	4	0	284
06:45	1	118	2	0	3	0	3	0	4	125	1	0	1	1	4	0	263
Total	2	432	5	0	5	0	10	0	5	441	7	0	3	1	11	0	922
07:00	4	116	0	1	2	0	4	0	0	126	9	0	1	0	2	1	266
07:15	2	147	7	0	1	0	2	0	3	155	0	0	1	0	1	0	319
07:30	3	167	7	0	0	0	4	0	3	181	1	1	4	1	7	0	379
07:45	6	161	8	1	1	0	1	0	2	216	3	0	4	0	3	0	406
Total	15	591	22	2	4	0	11	0	8	678	13	1	10	1	13	1	1370
08:00	5	143	10	0	0	0	3	0	2	167	7	0	3	0	3	0	343
08:15	1	132	12	0	0	1	3	0	4	162	4	1	0	2	6	0	328
08:30	3	131	6	0	1	0	1	2	4	149	6	1	4	1	0	0	309
08:45	2	113	9	0	0	3	0	2	5	132	1	0	3	1	5	0	276
Total	11	519	37	0	1	4	7	4	15	610	18	2	10	4	14	0	1256
15:00	3	149	12	1	2	0	6	1	1	148	4	6	9	3	2	0	347
15:15	5	135	20	0	3	0	2	0	5	146	4	2	7	2	0	1	332
15:30	3	167	11	4	1	0	2	0	6	145	4	2	3	1	7	0	356
15:45	3	168	11	1	2	3	4	0	4	152	4	5	4	2	4	0	367
Total	14	619	54	6	8	3	14	1	16	591	16	15	23	8	13	1	1402
16:00	5	179	14	2	0	1	4	3	7	177	6	6	4	1	7	1	417
16:15	2	239	8	3	2	2	3	3	7	165	2	3	6	1	7	0	453
16:30	7	224	14	0	2	0	8	0	12	208	3	1	3	0	6	0	488
16:45	7	213	16	3	2	1	2	0	6	205	7	10	4	3	5	0	484
Total	21	855	52	8	6	4	17	6	32	755	18	20	17	5	25	1	1842
17:00	2	216	5	0	2	1	5	0	2	178	10	0	4	0	9	0	434
17:15	9	238	4	1	0	1	8	0	5	225	0	1	3	3	5	0	503
17:30	0	192	3	0	1	0	3	0	2	193	2	0	4	1	9	0	410
17:45	4	167	4	2	2	6	2	0	2	171	2	1	3	2	5	0	373
Total	15	813	16	3	5	8	18	0	11	767	14	2	14	6	28	0	1720
Grand Total	78	3829	186	19	29	19	77	11	87	3842	86	40	77	25	104	3	8512
Apprch %	1.9	93.1	4.5	0.5	21.3	14	56.6	8.1	2.1	94.7	2.1	1	36.8	12	49.8	1.4	
Total %	0.9	45	2.2	0.2	0.3	0.2	0.9	0.1	1	45.1	1	0.5	0.9	0.3	1.2	0	



# MINNESOTA DEPT OF TRANSPORTATION

## TRAFFIC DATA COLLECTION - METRO

TH-41 at 3rd St., CHASKA  
 Ref.Pt.: 001.812  
 JAMAR # D4-3365 CH  
 TURN MOVEMENT COUNT

File Name : TH-41 at 3rd St CHASKA 2009  
 Site Code : 00000000  
 Start Date : 6/30/2009  
 Page No : 2

Start Time	TH-41 / CHESTNUT ST Southbound					3RD ST. Westbound					TH-41 / CHESTNUT ST Northbound					3RD ST. Eastbound					Int. Total
	Left	Thru	Right	Peds	App. Total	Left	Thru	Right	Peds	App. Total	Left	Thru	Right	Peds	App. Total	Left	Thru	Right	Peds	App. Total	
Peak Hour Analysis From 06:00 to 08:45 - Peak 1 of 1																					
Peak Hour for Entire Intersection Begins at 07:30																					
07:30	3	167	7	0	177	0	0	4	0	4	3	181	1	1	186	4	1	7	0	12	379
07:45	6	161	8	1	176	1	0	1	0	2	2	216	3	0	221	4	0	3	0	7	406
08:00	5	143	10	0	158	0	0	3	0	3	2	167	7	0	176	3	0	3	0	6	343
08:15	1	132	12	0	145	0	1	3	0	4	4	162	4	1	171	0	2	6	0	8	328
Total Volume	15	603	37	1	656	1	1	11	0	13	11	726	15	2	754	11	3	19	0	33	1456
% App. Total	2.3	91.9	5.6	0.2		7.7	7.7	84.6	0		1.5	96.3	2	0.3		33.3	9.1	57.6	0		
PHF	.625	.903	.771	.250	.927	.250	.250	.688	.000	.813	.688	.840	.536	.500	.853	.688	.375	.679	.000	.688	.897

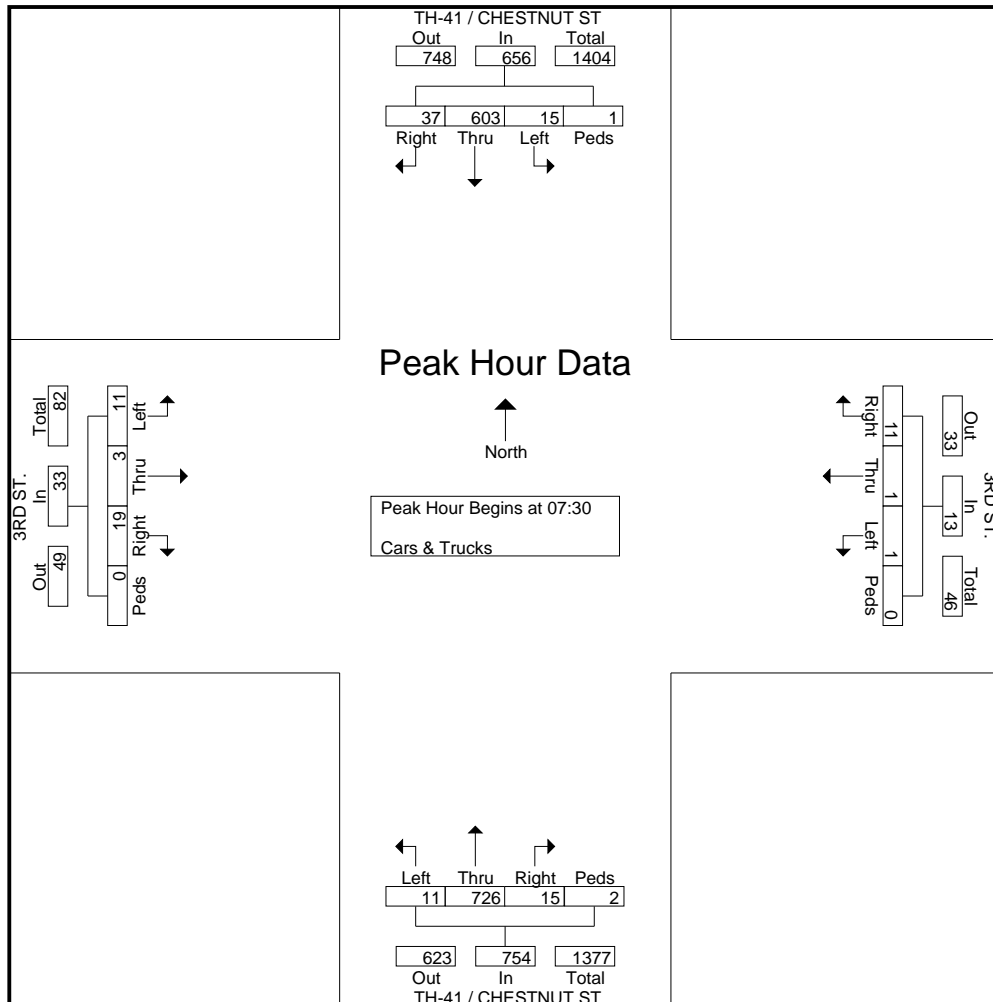



# MINNESOTA DEPT OF TRANSPORTATION

## TRAFFIC DATA COLLECTION - METRO

TH-41 at 3rd St., CHASKA  
 Ref.Pt.: 001.812  
 JAMAR # D4-3365 CH  
 TURN MOVEMENT COUNT

File Name : TH-41 at 3rd St CHASKA 2009  
 Site Code : 00000000  
 Start Date : 6/30/2009  
 Page No : 3

Start Time	TH-41 / CHESTNUT ST Southbound					3RD ST. Westbound					TH-41 / CHESTNUT ST Northbound					3RD ST. Eastbound					Int. Total
	Left	Thru	Right	Peds	App. Total	Left	Thru	Right	Peds	App. Total	Left	Thru	Right	Peds	App. Total	Left	Thru	Right	Peds	App. Total	
Peak Hour Analysis From 15:00 to 17:45 - Peak 1 of 1																					
Peak Hour for Entire Intersection Begins at 16:30																					
16:30	7	224	14	0	245	2	0	8	0	10	12	208	3	1	224	3	0	6	0	9	488
16:45	7	213	16	3	239	2	1	2	0	5	6	205	7	10	228	4	3	5	0	12	484
17:00	2	216	5	0	223	2	1	5	0	8	2	178	10	0	190	4	0	9	0	13	434
17:15	9	238	4	1	252	0	1	8	0	9	5	225	0	1	231	3	3	5	0	11	503
Total Volume	25	891	39	4	959	6	3	23	0	32	25	816	20	12	873	14	6	25	0	45	1909
% App. Total	2.6	92.9	4.1	0.4		18.8	9.4	71.9	0		2.9	93.5	2.3	1.4		31.1	13.3	55.6	0		
PHF	.694	.936	.609	.333	.951	.750	.750	.719	.000	.800	.521	.907	.500	.300	.945	.875	.500	.694	.000	.865	.949

