



MINNESOTA DEPT OF TRANSPORTATION

TRAFFIC DATA COLLECTION - METRO

TH-41 at Engler Blvd / CSAH-10
 Ref.Pt.: 003.113
 Data by: Westwood Professional Services
 TURN MOVEMENT COUNT

File Name : TH-41 at Engler Blvd 2008
 Site Code : 26053428
 Start Date : 10/28/2008
 Page No : 1

Groups Printed- Unshifted

| Start Time | TH-41 Southbound | | | | Engler Blvd. / CSAH-10 Westbound | | | | TH-41 Northbound | | | | Engler Blvd. / CSAH-10 Eastbound | | | | Int. Total |
|---------------|------------------|------|-------|------|----------------------------------|------|-------|------|------------------|------|-------|------|----------------------------------|------|-------|------|------------|
| | Left | Thru | Right | Peds | Left | Thru | Right | Peds | Left | Thru | Right | Peds | Left | Thru | Right | Peds | |
| 06:00 | 2 | 26 | 9 | 0 | 4 | 12 | 12 | 1 | 5 | 71 | 3 | 0 | 32 | 24 | 8 | 0 | 209 |
| 06:15 | 8 | 26 | 4 | 0 | 2 | 20 | 21 | 0 | 12 | 104 | 3 | 0 | 34 | 37 | 16 | 0 | 287 |
| 06:30 | 11 | 53 | 10 | 0 | 7 | 25 | 32 | 0 | 18 | 125 | 5 | 0 | 35 | 45 | 14 | 0 | 380 |
| 06:45 | 16 | 53 | 10 | 0 | 7 | 23 | 30 | 0 | 27 | 142 | 15 | 0 | 40 | 83 | 23 | 0 | 469 |
| Total | 37 | 158 | 33 | 0 | 20 | 80 | 95 | 1 | 62 | 442 | 26 | 0 | 141 | 189 | 61 | 0 | 1345 |
| 07:00 | 15 | 53 | 12 | 0 | 13 | 30 | 43 | 0 | 26 | 139 | 33 | 0 | 49 | 108 | 13 | 0 | 534 |
| 07:15 | 29 | 69 | 14 | 0 | 17 | 42 | 54 | 0 | 26 | 170 | 16 | 0 | 32 | 107 | 20 | 0 | 596 |
| 07:30 | 11 | 99 | 13 | 0 | 5 | 34 | 27 | 0 | 25 | 158 | 9 | 0 | 48 | 75 | 42 | 0 | 546 |
| 07:45 | 17 | 88 | 14 | 0 | 5 | 24 | 31 | 0 | 29 | 209 | 9 | 0 | 63 | 114 | 32 | 0 | 635 |
| Total | 72 | 309 | 53 | 0 | 40 | 130 | 155 | 0 | 106 | 676 | 67 | 0 | 192 | 404 | 107 | 0 | 2311 |
| 08:00 | 12 | 94 | 13 | 2 | 5 | 28 | 16 | 0 | 19 | 154 | 8 | 0 | 41 | 51 | 24 | 0 | 467 |
| 08:15 | 11 | 103 | 21 | 0 | 3 | 23 | 32 | 0 | 19 | 139 | 5 | 0 | 30 | 41 | 27 | 0 | 454 |
| 08:30 | 10 | 86 | 24 | 0 | 4 | 20 | 21 | 0 | 29 | 103 | 5 | 0 | 40 | 56 | 24 | 0 | 422 |
| 08:45 | 13 | 86 | 21 | 0 | 7 | 21 | 22 | 0 | 24 | 130 | 4 | 0 | 36 | 36 | 30 | 0 | 430 |
| Total | 46 | 369 | 79 | 2 | 19 | 92 | 91 | 0 | 91 | 526 | 22 | 0 | 147 | 184 | 105 | 0 | 1773 |
| *** BREAK *** | | | | | | | | | | | | | | | | | |
| 11:00 | 10 | 85 | 19 | 0 | 4 | 20 | 17 | 1 | 25 | 107 | 6 | 0 | 11 | 21 | 27 | 0 | 353 |
| 11:15 | 26 | 104 | 23 | 0 | 8 | 23 | 14 | 0 | 34 | 110 | 7 | 0 | 24 | 25 | 22 | 0 | 420 |
| 11:30 | 21 | 111 | 13 | 0 | 6 | 37 | 25 | 0 | 28 | 134 | 7 | 0 | 23 | 17 | 25 | 0 | 447 |
| 11:45 | 7 | 117 | 17 | 0 | 7 | 27 | 16 | 0 | 18 | 118 | 3 | 0 | 18 | 28 | 29 | 0 | 405 |
| Total | 64 | 417 | 72 | 0 | 25 | 107 | 72 | 1 | 105 | 469 | 23 | 0 | 76 | 91 | 103 | 0 | 1625 |
| 12:00 | 17 | 104 | 15 | 0 | 5 | 21 | 17 | 0 | 34 | 119 | 5 | 0 | 12 | 20 | 24 | 0 | 393 |
| 12:15 | 16 | 134 | 31 | 0 | 7 | 29 | 21 | 0 | 31 | 120 | 7 | 0 | 20 | 32 | 25 | 0 | 473 |
| 12:30 | 13 | 138 | 16 | 0 | 4 | 14 | 21 | 0 | 33 | 118 | 5 | 0 | 22 | 21 | 18 | 0 | 423 |
| 12:45 | 14 | 129 | 20 | 0 | 3 | 18 | 17 | 0 | 24 | 153 | 12 | 0 | 20 | 23 | 34 | 0 | 467 |
| Total | 60 | 505 | 82 | 0 | 19 | 82 | 76 | 0 | 122 | 510 | 29 | 0 | 74 | 96 | 101 | 0 | 1756 |
| *** BREAK *** | | | | | | | | | | | | | | | | | |
| 15:00 | 23 | 126 | 26 | 0 | 16 | 40 | 19 | 0 | 29 | 90 | 10 | 0 | 28 | 26 | 29 | 0 | 462 |
| 15:15 | 26 | 164 | 46 | 0 | 8 | 58 | 15 | 0 | 31 | 97 | 14 | 0 | 26 | 35 | 19 | 0 | 539 |
| 15:30 | 30 | 146 | 43 | 0 | 15 | 62 | 26 | 0 | 61 | 132 | 11 | 0 | 18 | 36 | 35 | 0 | 615 |
| 15:45 | 24 | 144 | 33 | 0 | 8 | 73 | 21 | 0 | 49 | 121 | 11 | 0 | 24 | 55 | 25 | 0 | 588 |
| Total | 103 | 580 | 148 | 0 | 47 | 233 | 81 | 0 | 170 | 440 | 46 | 0 | 96 | 152 | 108 | 0 | 2204 |
| 16:00 | 29 | 168 | 42 | 0 | 7 | 54 | 20 | 0 | 35 | 120 | 11 | 0 | 30 | 37 | 22 | 0 | 575 |
| 16:15 | 26 | 150 | 48 | 0 | 11 | 66 | 22 | 0 | 42 | 122 | 14 | 0 | 22 | 41 | 33 | 0 | 597 |
| 16:30 | 23 | 175 | 61 | 0 | 11 | 57 | 23 | 0 | 49 | 167 | 8 | 0 | 27 | 40 | 28 | 0 | 669 |
| 16:45 | 23 | 143 | 40 | 0 | 11 | 76 | 19 | 0 | 51 | 160 | 16 | 0 | 25 | 46 | 38 | 0 | 648 |
| Total | 101 | 636 | 191 | 0 | 40 | 253 | 84 | 0 | 177 | 569 | 49 | 0 | 104 | 164 | 121 | 0 | 2489 |
| 17:00 | 26 | 155 | 60 | 0 | 16 | 77 | 19 | 0 | 36 | 154 | 10 | 0 | 32 | 44 | 26 | 0 | 655 |
| 17:15 | 35 | 167 | 36 | 0 | 11 | 60 | 16 | 0 | 46 | 132 | 11 | 0 | 25 | 60 | 31 | 0 | 630 |
| 17:30 | 35 | 146 | 46 | 0 | 10 | 52 | 25 | 0 | 36 | 121 | 6 | 0 | 32 | 38 | 29 | 0 | 576 |
| 17:45 | 27 | 127 | 38 | 0 | 7 | 59 | 29 | 0 | 46 | 100 | 6 | 0 | 15 | 33 | 27 | 0 | 514 |
| Total | 123 | 595 | 180 | 0 | 44 | 248 | 89 | 0 | 164 | 507 | 33 | 0 | 104 | 175 | 113 | 0 | 2375 |
| Grand Total | 606 | 3569 | 838 | 2 | 254 | 1225 | 743 | 2 | 997 | 4139 | 295 | 0 | 934 | 1455 | 819 | 0 | 15878 |
| Apprch % | 12.1 | 71.2 | 16.7 | 0 | 11.4 | 55.1 | 33.4 | 0.1 | 18.4 | 76.2 | 5.4 | 0 | 29.1 | 45.4 | 25.5 | 0 | |
| Total % | 3.8 | 22.5 | 5.3 | 0 | 1.6 | 7.7 | 4.7 | 0 | 6.3 | 26.1 | 1.9 | 0 | 5.9 | 9.2 | 5.2 | 0 | |



MINNESOTA DEPT OF TRANSPORTATION

TRAFFIC DATA COLLECTION - METRO

TH-41 at Engler Blvd / CSAH-10
 Ref.Pt.: 003.113
 Data by: Westwood Professional Services
 TURN MOVEMENT COUNT

File Name : TH-41 at Engler Blvd 2008
 Site Code : 26053428
 Start Date : 10/28/2008
 Page No : 2

| Start Time | TH-41 Southbound | | | | | Engler Blvd. / CSAH-10 Westbound | | | | | TH-41 Northbound | | | | | Engler Blvd. / CSAH-10 Eastbound | | | | | Int. Total |
|--|------------------|------|-------|------|------------|----------------------------------|------|-------|------|------------|------------------|------|-------|------|------------|----------------------------------|------|-------|------|------------|------------|
| | Left | Thru | Right | Peds | App. Total | Left | Thru | Right | Peds | App. Total | Left | Thru | Right | Peds | App. Total | Left | Thru | Right | Peds | App. Total | |
| Peak Hour Analysis From 06:00 to 08:45 - Peak 1 of 1 | | | | | | | | | | | | | | | | | | | | | |
| Peak Hour for Entire Intersection Begins at 07:00 | | | | | | | | | | | | | | | | | | | | | |
| 07:00 | 15 | 53 | 12 | 0 | 80 | 13 | 30 | 43 | 0 | 86 | 26 | 139 | 33 | 0 | 198 | 49 | 108 | 13 | 0 | 170 | 534 |
| 07:15 | 29 | 69 | 14 | 0 | 112 | 17 | 42 | 54 | 0 | 113 | 26 | 170 | 16 | 0 | 212 | 32 | 107 | 20 | 0 | 159 | 596 |
| 07:30 | 11 | 99 | 13 | 0 | 123 | 5 | 34 | 27 | 0 | 66 | 25 | 158 | 9 | 0 | 192 | 48 | 75 | 42 | 0 | 165 | 546 |
| 07:45 | 17 | 88 | 14 | 0 | 119 | 5 | 24 | 31 | 0 | 60 | 29 | 209 | 9 | 0 | 247 | 63 | 114 | 32 | 0 | 209 | 635 |
| Total Volume | 72 | 309 | 53 | 0 | 434 | 40 | 130 | 155 | 0 | 325 | 106 | 676 | 67 | 0 | 849 | 192 | 404 | 107 | 0 | 703 | 2311 |
| % App. Total | 16.6 | 71.2 | 12.2 | 0 | | 12.3 | 40 | 47.7 | 0 | | 12.5 | 79.6 | 7.9 | 0 | | 27.3 | 57.5 | 15.2 | 0 | | |
| PHF | .621 | .780 | .946 | .000 | .882 | .588 | .774 | .718 | .000 | .719 | .914 | .809 | .508 | .000 | .859 | .762 | .886 | .637 | .000 | .841 | .910 |

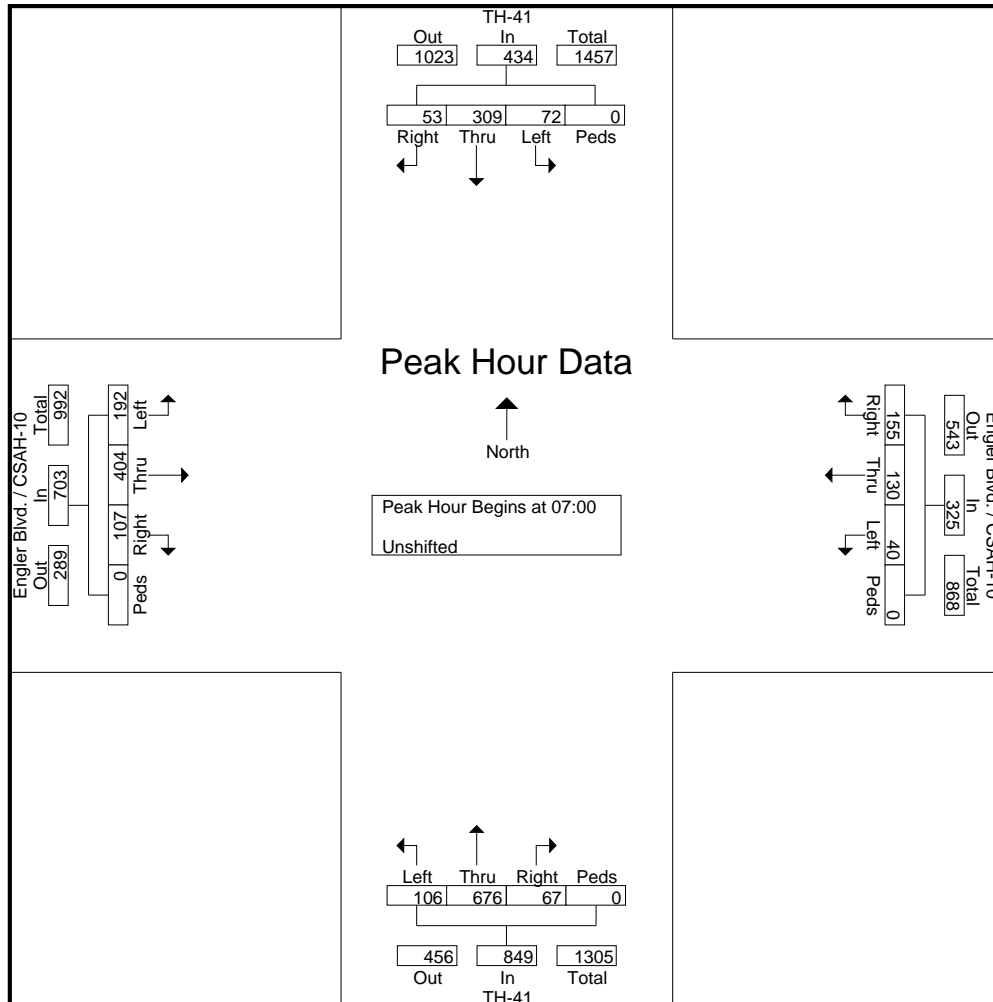



MINNESOTA DEPT OF TRANSPORTATION

TRAFFIC DATA COLLECTION - METRO

TH-41 at Engler Blvd / CSAH-10
 Ref.Pt.: 003.113
 Data by: Westwood Professional Services
 TURN MOVEMENT COUNT

File Name : TH-41 at Engler Blvd 2008
 Site Code : 26053428
 Start Date : 10/28/2008
 Page No : 3

| Start Time | TH-41 Southbound | | | | | Engler Blvd. / CSAH-10 Westbound | | | | | TH-41 Northbound | | | | | Engler Blvd. / CSAH-10 Eastbound | | | | | Int. Total |
|--------------|------------------|------|-------|------|------------|----------------------------------|------|-------|------|------------|------------------|------|-------|------|------------|----------------------------------|------|-------|------|------------|------------|
| | Left | Thru | Right | Peds | App. Total | Left | Thru | Right | Peds | App. Total | Left | Thru | Right | Peds | App. Total | Left | Thru | Right | Peds | App. Total | |
| 16:30 | 23 | 175 | 61 | 0 | 259 | 11 | 57 | 23 | 0 | 91 | 49 | 167 | 8 | 0 | 224 | 27 | 40 | 28 | 0 | 95 | 669 |
| 16:45 | 23 | 143 | 40 | 0 | 206 | 11 | 76 | 19 | 0 | 106 | 51 | 160 | 16 | 0 | 227 | 25 | 46 | 38 | 0 | 109 | 648 |
| 17:00 | 26 | 155 | 60 | 0 | 241 | 16 | 77 | 19 | 0 | 112 | 36 | 154 | 10 | 0 | 200 | 32 | 44 | 26 | 0 | 102 | 655 |
| 17:15 | 35 | 167 | 36 | 0 | 238 | 11 | 60 | 16 | 0 | 87 | 46 | 132 | 11 | 0 | 189 | 25 | 60 | 31 | 0 | 116 | 630 |
| Total Volume | 107 | 640 | 197 | 0 | 944 | 49 | 270 | 77 | 0 | 396 | 182 | 613 | 45 | 0 | 840 | 109 | 190 | 123 | 0 | 422 | 2602 |
| % App. Total | 11.3 | 67.8 | 20.9 | 0 | | 12.4 | 68.2 | 19.4 | 0 | | 21.7 | 73 | 5.4 | 0 | | 25.8 | 45 | 29.1 | 0 | | |
| PHF | .764 | .914 | .807 | .000 | .911 | .766 | .877 | .837 | .000 | .884 | .892 | .918 | .703 | .000 | .925 | .852 | .792 | .809 | .000 | .909 | .972 |

Peak Hour Analysis From 15:00 to 17:45 - Peak 1 of 1

Peak Hour for Entire Intersection Begins at 16:30

