

**Alliant Engineering, Inc**

233 Park Ave Suite 300  
 Minneapolis, MN 55415

--TRAFFIC DATA --

TH 47 & Mississippi St  
 Ref.Pt.: 8.904  
 data by : Alliant Inc.  
 TURN MOVEMENT COUNT

File Name : 610\_TH 47 & Mississippi St NE  
 Site Code : 610\_\_\_\_\_  
 Start Date : 2/28/2018  
 Page No : 1

Groups Printed- Class 1 - Class 2

Start Time	TH 47 From North					Mississippi St From East					TH 47 From South					Mississippi St From West					Int. Total
	Other	Rght	Thru	Left	App. Total	Other	Rght	Thru	Left	App. Total	Other	Rght	Thru	Left	App. Total	Other	Rght	Thru	Left	App. Total	
06:00 AM	0	13	188	6	207	0	2	3	7	12	0	3	98	5	106	1	11	9	8	29	354
06:15 AM	0	17	297	5	319	0	9	11	12	32	0	3	112	6	121	0	3	9	4	16	488
06:30 AM	1	17	278	1	297	0	14	15	18	47	0	8	157	5	170	0	4	9	2	15	529
06:45 AM	3	17	296	18	334	2	16	13	21	52	1	5	158	6	170	3	9	23	5	40	596
Total	4	64	1059	30	1157	2	41	42	58	143	1	19	525	22	567	4	27	50	19	100	1967
07:00 AM	1	10	363	5	379	0	19	21	9	49	0	9	134	6	149	1	8	16	11	36	613
07:15 AM	0	18	384	8	410	0	25	36	15	76	1	8	159	5	173	0	13	28	5	46	705
07:30 AM	0	13	440	10	463	0	23	29	14	66	1	12	165	6	184	0	21	39	4	64	777
07:45 AM	0	25	419	5	449	0	33	33	22	88	0	22	173	14	209	0	13	35	11	59	805
Total	1	66	1606	28	1701	0	100	119	60	279	2	51	631	31	715	1	55	118	31	205	2900
08:00 AM	0	17	330	20	367	0	31	31	17	79	0	19	149	9	177	0	18	33	12	63	686
08:15 AM	0	28	299	24	351	0	18	27	17	62	0	9	171	10	190	0	14	16	8	38	641
08:30 AM	2	33	252	17	304	0	24	30	15	69	2	10	136	11	159	0	13	17	16	46	578
08:45 AM	1	27	179	10	217	0	37	24	21	82	0	19	181	19	219	1	14	24	14	53	571
Total	3	105	1060	71	1239	0	110	112	70	292	2	57	637	49	745	1	59	90	50	200	2476
09:00 AM	0	18	193	15	226	0	30	26	32	88	0	17	168	8	193	0	24	24	26	74	581
09:15 AM	3	18	175	9	205	0	25	21	23	69	2	12	146	5	165	0	11	21	14	46	485
*** BREAK ***																					
Total	3	36	368	24	431	0	55	47	55	157	2	29	314	13	358	0	35	45	40	120	1066
*** BREAK ***																					
10:30 AM	1	13	186	17	217	0	35	10	8	53	0	8	170	14	192	1	21	7	9	38	500
10:45 AM	4	12	183	25	224	0	25	8	14	47	1	12	171	14	198	0	19	9	17	45	514
Total	5	25	369	42	441	0	60	18	22	100	1	20	341	28	390	1	40	16	26	83	1014
11:00 AM	1	19	214	16	250	0	30	16	19	65	1	8	174	30	213	0	21	16	17	54	582
11:15 AM	3	11	181	32	227	0	29	9	14	52	1	13	155	43	212	0	16	16	13	45	536
11:30 AM	0	11	206	22	239	0	30	16	9	55	0	17	185	13	215	0	18	15	17	50	559
11:45 AM	0	16	185	29	230	0	41	14	14	69	0	12	214	9	235	0	14	21	14	49	583
Total	4	57	786	99	946	0	130	55	56	241	2	50	728	95	875	0	69	68	61	198	2260
12:00 PM	0	11	204	28	243	0	33	18	18	69	0	14	182	14	210	0	25	31	19	75	597
12:15 PM	3	15	223	25	266	0	33	20	16	69	1	18	195	6	220	0	23	23	18	64	619
12:30 PM	1	11	209	27	248	0	24	15	14	53	1	14	209	17	241	0	16	19	12	47	589
12:45 PM	4	11	190	25	230	0	36	15	13	64	2	14	199	10	225	0	18	23	13	54	573
Total	8	48	826	105	987	0	126	68	61	255	4	60	785	47	896	0	82	96	62	240	2378
01:00 PM	0	11	206	25	242	0	33	15	15	63	0	17	197	11	225	0	13	19	12	44	574
01:15 PM	0	12	195	43	250	0	31	13	22	66	1	16	222	12	251	0	19	12	12	43	610
*** BREAK ***																					
Total	0	23	401	68	492	0	64	28	37	129	1	33	419	23	476	0	32	31	24	87	1184
*** BREAK ***																					
02:30 PM	0	15	222	21	258	0	1	1	0	2	0	15	282	18	315	0	1	7	1	9	584
02:45 PM	3	21	227	31	282	0	24	23	13	60	1	22	294	19	336	0	11	30	21	62	740
Total	3	36	449	52	540	0	25	24	13	62	1	37	576	37	651	0	12	37	22	71	1324
03:00 PM	0	13	255	39	307	0	31	30	9	70	1	20	307	21	349	0	35	25	21	81	807
03:15 PM	0	5	289	21	315	0	46	31	21	98	0	24	338	22	384	0	22	18	32	72	869
03:30 PM	2	10	267	24	303	0	31	32	17	80	2	31	330	22	385	0	15	33	25	73	841
03:45 PM	2	13	248	18	281	0	45	18	19	82	1	18	358	19	396	0	19	39	27	85	844
Total	4	41	1059	102	1206	0	153	111	66	330	4	93	1333	84	1514	0	91	115	105	311	3361
04:00 PM	3	13	255	23	294	0	40	27	22	89	1	26	313	19	359	0	23	39	27	89	831
04:15 PM	0	16	255	31	302	0	27	24	29	80	0	23	345	27	395	0	21	34	29	84	861
04:30 PM	1	14	287	20	322	0	46	42	13	101	0	23	382	20	425	0	14	40	20	74	922
04:45 PM	1	22	252	13	288	0	49	41	26	116	1	24	404	12	441	0	23	33	27	83	928
Total	5	65	1049	87	1206	0	162	134	90	386	2	96	1444	78	1620	0	81	146	103	330	3542

**Alliant Engineering, Inc**

233 Park Ave Suite 300  
 Minneapolis, MN 55415

--TRAFFIC DATA --

TH 47 & Mississippi St  
 Ref.Pt.: 8.904  
 data by : Alliant Inc.  
 TURN MOVEMENT COUNT

File Name : 610\_TH 47 & Mississippi St NE  
 Site Code : 610\_\_\_\_\_  
 Start Date : 2/28/2018  
 Page No : 2

Groups Printed- Class 1 - Class 2

Start Time	TH 47 From North					Mississippi St From East					TH 47 From South					Mississippi St From West					Int. Total
	Other	Rght	Thru	Left	App. Total	Other	Rght	Thru	Left	App. Total	Other	Rght	Thru	Left	App. Total	Other	Rght	Thru	Left	App. Total	
05:00 PM	2	11	255	23	291	0	37	45	10	92	1	39	366	32	438	0	24	43	15	82	903
05:15 PM	2	28	257	25	312	0	41	41	34	116	1	23	347	27	398	0	30	41	28	99	925
05:30 PM	1	21	203	30	255	1	40	47	21	109	1	31	348	18	398	1	21	44	23	89	851
05:45 PM	1	14	218	25	258	0	22	33	15	70	4	30	297	18	349	0	16	33	32	81	758
Total	6	74	933	103	1116	1	140	166	80	387	7	123	1358	95	1583	1	91	161	98	351	3437
Grand Total	46	640	9965	811	11462	3	1166	924	668	2761	29	668	9091	602	10390	8	674	973	641	2296	26909
Apprch %	0.4	5.6	86.9	7.1		0.1	42.2	33.5	24.2		0.3	6.4	87.5	5.8		0.3	29.4	42.4	27.9		
Total %	0.2	2.4	37	3	42.6	0	4.3	3.4	2.5	10.3	0.1	2.5	33.8	2.2	38.6	0	2.5	3.6	2.4	8.5	
Class 1	46	605	9470	789	10910	2	1130	871	651	2654	29	636	8572	558	9795	8	639	920	600	2167	25526
% Class 1	100	94.5	95	97.3	95.2	66.7	96.9	94.3	97.5	96.1	100	95.2	94.3	92.7	94.3	100	94.8	94.6	93.6	94.4	94.9
Class 2	0	35	495	22	552	1	36	53	17	107	0	32	519	44	595	0	35	53	41	129	1383
% Class 2	0	5.5	5	2.7	4.8	33.3	3.1	5.7	2.5	3.9	0	4.8	5.7	7.3	5.7	0	5.2	5.4	6.4	5.6	5.1

**Alliant Engineering, Inc**

233 Park Ave Suite 300  
 Minneapolis, MN 55415  
 --TRAFFIC DATA --

TH 47 & Mississippi St  
 Ref.Pt.: 8.904  
 data by : Alliant Inc.  
 TURN MOVEMENT COUNT

File Name : 610\_TH 47 & Mississippi St NE  
 Site Code : 610\_\_\_\_\_  
 Start Date : 2/28/2018  
 Page No : 3

Start Time	TH 47 From North					Mississippi St From East					TH 47 From South					Mississippi St From West					Int. Total
	Other	Rght	Thru	Left	App. Total	Other	Rght	Thru	Left	App. Total	Other	Rght	Thru	Left	App. Total	Other	Rght	Thru	Left	App. Total	
Peak Hour Analysis From 06:00 AM to 11:45 AM - Peak 1 of 1																					
Peak Hour for Entire Intersection Begins at 07:15 AM																					
07:15 AM	0	18	384	8	410	0	25	36	15	76	1	8	159	5	173	0	13	28	5	46	705
07:30 AM	0	13	440	10	463	0	23	29	14	66	1	12	165	6	184	0	21	39	4	64	777
07:45 AM	0	25	419	5	449	0	33	33	22	88	0	22	173	14	209	0	13	35	11	59	805
08:00 AM	0	17	330	20	367	0	31	31	17	79	0	19	149	9	177	0	18	33	12	63	686
Total Volume	0	73	1573	43	1689	0	112	129	68	309	2	61	646	34	743	0	65	135	32	232	2973
% App. Total	0	4.3	93.1	2.5		0	36.2	41.7	22		0.3	8.2	86.9	4.6		0	28	58.2	13.8		
PHF	.000	.730	.894	.538	.912	.000	.848	.896	.773	.878	.500	.693	.934	.607	.889	.000	.774	.865	.667	.906	.923

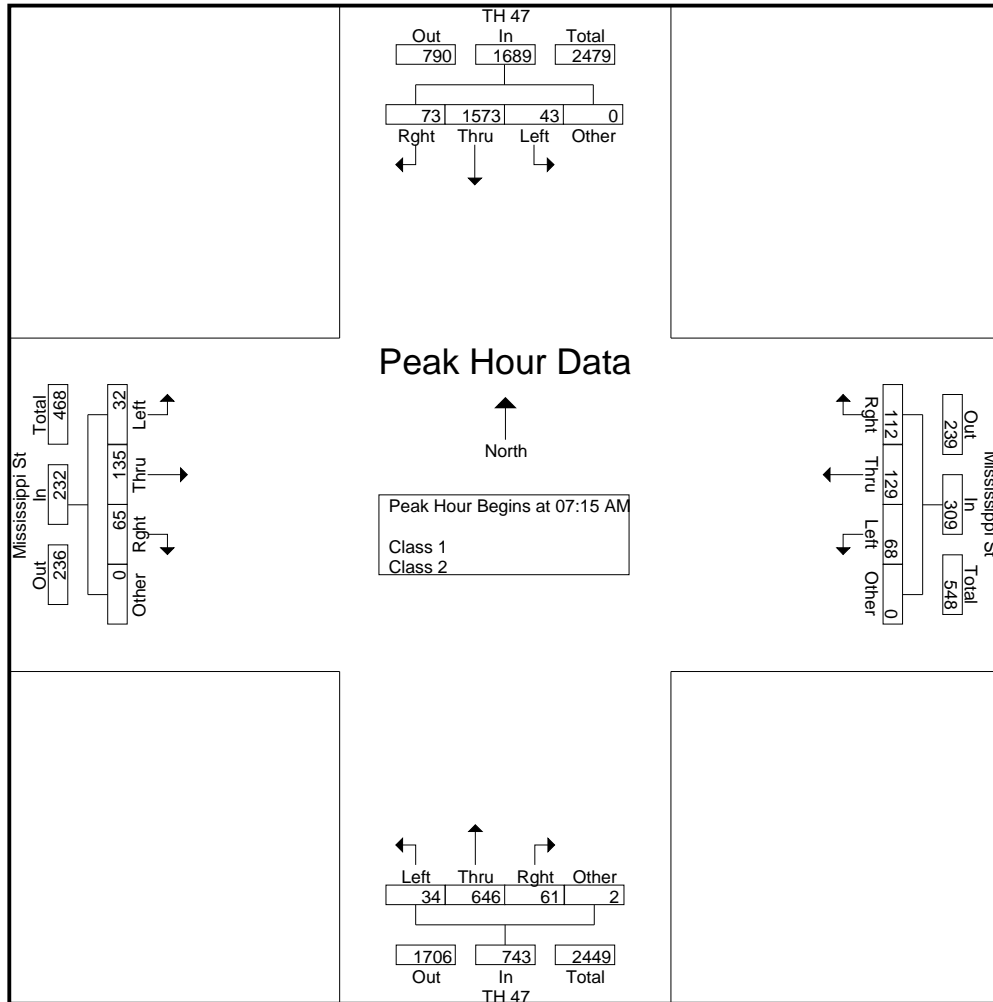

**Alliant Engineering, Inc**

233 Park Ave Suite 300  
 Minneapolis, MN 55415  
 --TRAFFIC DATA --

TH 47 & Mississippi St  
 Ref.Pt.: 8.904  
 data by : Alliant Inc.  
 TURN MOVEMENT COUNT

File Name : 610\_TH 47 & Mississippi St NE  
 Site Code : 610\_\_\_\_\_  
 Start Date : 2/28/2018  
 Page No : 4

Start Time	TH 47 From North					Mississippi St From East					TH 47 From South					Mississippi St From West					Int. Total
	Other	Rgh t	Thr u	Left	App. Total	Other	Rgh t	Thr u	Left	App. Total	Other	Rgh t	Thr u	Left	App. Total	Other	Rgh t	Thr u	Left	App. Total	
Peak Hour Analysis From 12:00 PM to 05:45 PM - Peak 1 of 1																					
Peak Hour for Entire Intersection Begins at 04:30 PM																					
04:30 PM	1	14	<b>287</b>	20	<b>322</b>	0	46	42	13	101	0	23	382	20	425	0	14	40	20	74	922
04:45 PM	1	22	252	13	288	0	<b>49</b>	41	26	<b>116</b>	1	24	<b>404</b>	12	<b>441</b>	0	23	33	27	83	<b>928</b>
05:00 PM	2	11	255	23	291	0	37	<b>45</b>	10	92	1	<b>39</b>	366	<b>32</b>	438	0	24	<b>43</b>	15	82	903
05:15 PM	2	<b>28</b>	257	<b>25</b>	312	0	41	41	<b>34</b>	116	1	23	347	27	398	0	<b>30</b>	41	<b>28</b>	<b>99</b>	925
Total Volume	6	75	1051	81	1213	0	173	169	83	425	3	109	1499	91	1702	0	91	157	90	338	3678
% App. Total	0.5	6.2	86.6	6.7		0	40.7	39.8	19.5		0.2	6.4	88.1	5.3		0	26.9	46.4	26.6		
PHF	.750	.670	.916	.810	.942	.000	.883	.939	.610	.916	.750	.699	.928	.711	.965	.000	.758	.913	.804	.854	.991

