

ALLIANT ENGINEERING, INC.

733 S Marquette Ave #700, Minneapolis, MN 55402

Intersection: TH 47 & Osborne Road
 Date: 3/21/2024
 Duration: 0600-1800

Site Code: 613
 Ref Pt: N/A
 Page No: 1 of 4

All Vehicles (Cars & Trucks) Printed

Start Time	TH 47 Southbound						Osborne Road Westbound						TH 47 Northbound						Osborne Road Eastbound						Int. Veh. Total	Int. Ped/Bike Total
	U-Turn	Left	Thru	Right	App. Total	Peds/Bikes	U-Turn	Left	Thru	Right	App. Total	Peds/Bikes	U-Turn	Left	Thru	Right	App. Total	Peds/Bikes	U-Turn	Left	Thru	Right	App. Total	Peds/Bikes		
6:00	1	6	96	5	108	--	--	11	19	5	35	--	--	10	56	16	82	--	--	1	9	6	16	--	241	--
6:15	--	19	129	14	162	1	--	15	9	8	32	--	--	6	70	13	89	--	--	4	17	2	23	--	306	1
6:30	--	41	136	12	189	--	--	23	15	8	46	--	--	17	78	21	116	--	--	8	12	4	24	--	375	--
6:45	--	35	148	20	203	1	--	27	20	12	59	--	--	13	109	43	165	--	--	4	20	7	31	1	458	2
Hour Total	1	101	509	51	662	2	--	76	63	33	172	--	--	46	313	93	452	--	--	17	58	19	94	1	1380	3
7:00	--	24	158	11	193	--	--	23	17	10	50	--	--	10	100	19	129	--	--	6	29	9	44	--	416	--
7:15	--	24	192	15	231	--	--	24	20	12	56	--	--	15	125	28	168	1	--	8	23	10	41	--	496	1
7:30	1	35	235	29	300	--	--	38	53	30	121	--	--	9	178	40	227	--	--	7	34	9	50	--	698	--
7:45	--	49	212	17	278	1	--	31	49	22	102	1	--	25	149	47	221	--	--	9	41	13	63	1	664	3
Hour Total	1	132	797	72	1002	1	--	116	139	74	329	1	--	59	552	134	745	1	--	30	127	41	198	1	2274	4
8:00	--	38	199	19	256	--	--	26	43	17	86	--	1	18	160	35	214	--	--	8	31	14	53	--	609	--
8:15	--	34	140	17	191	1	--	32	35	21	88	--	--	13	156	22	191	--	--	11	29	13	53	1	523	2
8:30	--	28	122	16	166	--	--	19	41	19	79	--	--	12	121	12	145	--	--	10	28	16	54	--	444	--
8:45	1	48	136	24	209	--	--	35	30	24	89	1	--	20	117	35	172	1	--	18	49	14	81	--	551	2
Hour Total	1	148	597	76	822	1	--	112	149	81	342	1	1	63	554	104	722	1	--	47	137	57	241	1	2127	4
9:00	2	18	146	19	185	--	--	25	37	34	96	--	--	20	205	42	267	--	--	13	25	5	43	--	591	--
9:15	2	23	111	24	160	1	--	24	26	25	75	--	--	12	133	23	168	1	--	11	22	22	55	1	458	3
9:30	--	20	141	17	178	--	--	22	22	23	67	--	--	22	147	19	188	--	--	8	18	10	36	--	469	--
9:45	1	33	147	13	194	--	--	15	35	24	74	--	--	14	157	29	200	--	--	24	25	11	60	1	528	1
Hour Total	5	94	545	73	717	1	--	86	120	106	312	--	--	68	642	113	823	1	--	56	90	48	194	2	2046	4
10:00	1	15	135	19	170	1	--	15	32	20	67	--	--	21	116	21	158	--	--	13	28	16	57	--	452	1
10:15	1	32	150	13	196	--	--	12	26	32	70	--	--	20	172	24	216	--	2	18	26	17	63	--	545	--
10:30	--	27	152	19	198	1	--	19	32	30	81	--	--	23	119	15	157	--	--	16	26	20	62	--	498	1
10:45	1	23	156	16	196	--	--	18	23	30	71	--	--	25	155	21	201	1	--	23	26	15	64	--	532	1
Hour Total	3	97	593	67	760	2	--	64	113	112	289	--	--	89	562	81	732	1	2	70	106	68	246	--	2027	3
11:00	1	33	137	16	187	--	--	14	49	29	92	--	--	19	164	13	196	--	--	22	34	18	74	--	549	--
11:15	--	15	129	16	160	1	--	24	30	29	83	--	--	26	187	18	231	--	1	19	31	26	77	--	551	1
11:30	1	26	195	19	241	--	1	13	36	23	73	--	--	29	203	14	246	--	--	29	38	17	84	--	644	--
11:45	--	30	170	28	228	--	--	30	52	29	111	--	--	34	186	15	235	--	--	22	34	26	82	--	656	--
Hour Total	2	104	631	79	816	1	1	81	167	110	359	--	--	108	740	60	908	--	1	92	137	87	317	--	2400	1
12:00	--	19	173	26	218	--	--	24	32	31	87	--	--	26	207	21	254	--	--	31	38	24	93	--	652	--
12:15	--	26	168	30	224	--	--	26	38	27	91	--	--	25	170	17	212	--	--	22	39	18	79	--	606	--
12:30	1	14	164	19	198	--	--	12	30	34	76	--	--	24	213	23	260	--	--	22	36	28	86	--	620	--
12:45	--	36	175	25	236	--	--	23	41	28	92	--	1	30	189	22	242	--	--	28	48	23	99	--	669	--
Hour Total	1	95	680	100	876	--	--	85	141	120	346	--	1	105	779	83	968	--	--	103	161	93	357	--	2547	--
13:00	1	12	199	26	238	--	--	27	34	24	85	1	--	19	191	15	225	2	--	17	28	18	63	1	611	4
13:15	1	27	174	21	223	1	--	29	35	30	94	--	3	17	199	18	237	3	--	25	39	18	82	--	636	4
13:30	2	28	176	19	225	--	--	30	37	31	98	--	--	22	219	26	267	1	--	24	30	13	67	--	657	1
13:45	1	22	194	12	229	--	--	25	41	27	93	--	--	23	184	20	227	1	--	21	38	32	91	--	640	1
Hour Total	5	89	743	78	915	1	--	111	147	112	370	1	3	81	793	79	956	7	--	87	135	81	303	1	2544	10
14:00	1	27	162	20	210	1	--	26	38	35	99	--	--	15	200	22	237	--	1	27	40	24	92	2	638	3
14:15	2	25	216	19	262	1	--	21	39	40	100	--	--	26	228	33	287	--	--	30	22	23	75	--	724	1
14:30	2	39	156	15	212	1	--	27	33	26	86	--	--	36	271	24	331	2	--	34	56	18	108	1	737	4
14:45	--	38	172	14	224	2	--	24	41	36	101	1	--	31	256	38	325	4	--	31	53	24	108	1	758	8
Hour Total	5	129	706	68	908	5	--	98	151	137	386	1	--	108	955	117	1180	6	1	122	171	89	383	4	2857	16
15:00	--	28	219	15	262	3	--	43	55	40	138	--	--	27	348	28	403	1	--	31	38	37	106	--	909	4
15:15	--	25	217	26	268	--	--	21	52	48	121	--	--	23	321	32	376	3	1	23	41	24	89	1	854	4
15:30	2	29	204	10	245	1	--	39	45	62	146	2	1	19	265	21	306	2	--	31	54	26	111	--	808	5
15:45	1	33	179	22	235	1	--	21	41	52	114	--	--	20	306	16	342	2	--	36	41	20	97	--	788	3
Hour Total	3	115	819	73	1010	5	--	124	193	202	519	2	1	89	1240	97	1427	8	1	121	174	107	403	1	3359	16
16:00	--	39	199	12	250	2	--	52	70	61	183	--	--	36	326	22	384	--	--	41	49	21	111	--	928	2
16:15	3	26	195	15	239	--	--	41	54	43	138	--	--	28	295	15	338	--	--	37	54	22	113	--		

ALLIANT ENGINEERING, INC.

733 S Marquette Ave #700, Minneapolis, MN 55402

Intersection: TH 47 & Osborne Road
 Date: 3/21/2024
 Duration: 0600-1800

Site Code: 613
 Ref Pt: N/A
 Page No: 2 of 4

All Vehicles (Cars & Trucks) Printed

Start Time	TH 47 Southbound						Osborne Road Westbound						TH 47 Northbound						Osborne Road Eastbound						Int. Veh. Total	Int. Ped/Bike Total
	U-Turn	Left	Thru	Right	App. Total	Peds/Bikes	U-Turn	Left	Thru	Right	App. Total	Peds/Bikes	U-Turn	Left	Thru	Right	App. Total	Peds/Bikes	U-Turn	Left	Thru	Right	App. Total	Peds/Bikes		
7:30	1	35	235	29	300	--	--	38	53	30	121	--	--	9	178	40	227	--	--	7	34	9	50	--	698	--
7:45	--	49	212	17	278	1	--	31	49	22	102	1	--	25	149	47	221	--	--	9	41	13	63	1	664	3
8:00	--	38	199	19	256	--	--	26	43	17	86	--	1	18	160	35	214	--	--	8	31	14	53	--	609	--
8:15	--	34	140	17	191	1	--	32	35	21	88	--	--	13	156	22	191	--	--	11	29	13	53	1	523	2
Hour Total	1	156	786	82	1025	2	--	127	180	90	397	1	1	65	643	144	853	--	--	35	135	49	219	2	2494	5
% of App.	0.1%	15.2%	76.7%	8.0%			0.0%	32.0%	45.3%	22.7%			0.1%	7.6%	75.4%	16.9%			0.0%	16.0%	61.6%	22.4%				
% of Total	0.0%	6.3%	31.5%	3.3%	41.1%	40.0%	0.0%	5.1%	7.2%	3.6%	15.9%	20.0%	0.0%	2.6%	25.8%	5.8%	34.2%	0.0%	0.0%	1.4%	5.4%	2.0%	8.8%	40.0%		
Cars Total	1	152	753	78	984	1	--	125	177	88	390	1	1	61	613	143	818	--	--	33	131	42	206	1	2398	3
Cars % of Movement	100%	97.4%	95.8%	95.1%	96.0%	33.3%	0.0%	98.4%	98.3%	97.8%	98.2%	33.3%	100%	93.8%	95.3%	99.3%	95.9%	0.0%	0.0%	94.3%	97.0%	85.7%	94.1%	33.3%	96.2%	
Trucks Total	--	4	33	4	41	1	--	2	3	2	7	--	--	4	30	1	35	--	--	2	4	7	13	1	96	2
Trucks % of Movement	0.0%	2.6%	4.2%	4.9%	4.0%	50.0%	0.0%	1.6%	1.7%	2.2%	1.8%	0.0%	0.0%	6.2%	4.7%	0.7%	4.1%	0.0%	0.0%	5.7%	3.0%	14.3%	5.9%	50.0%	3.8%	

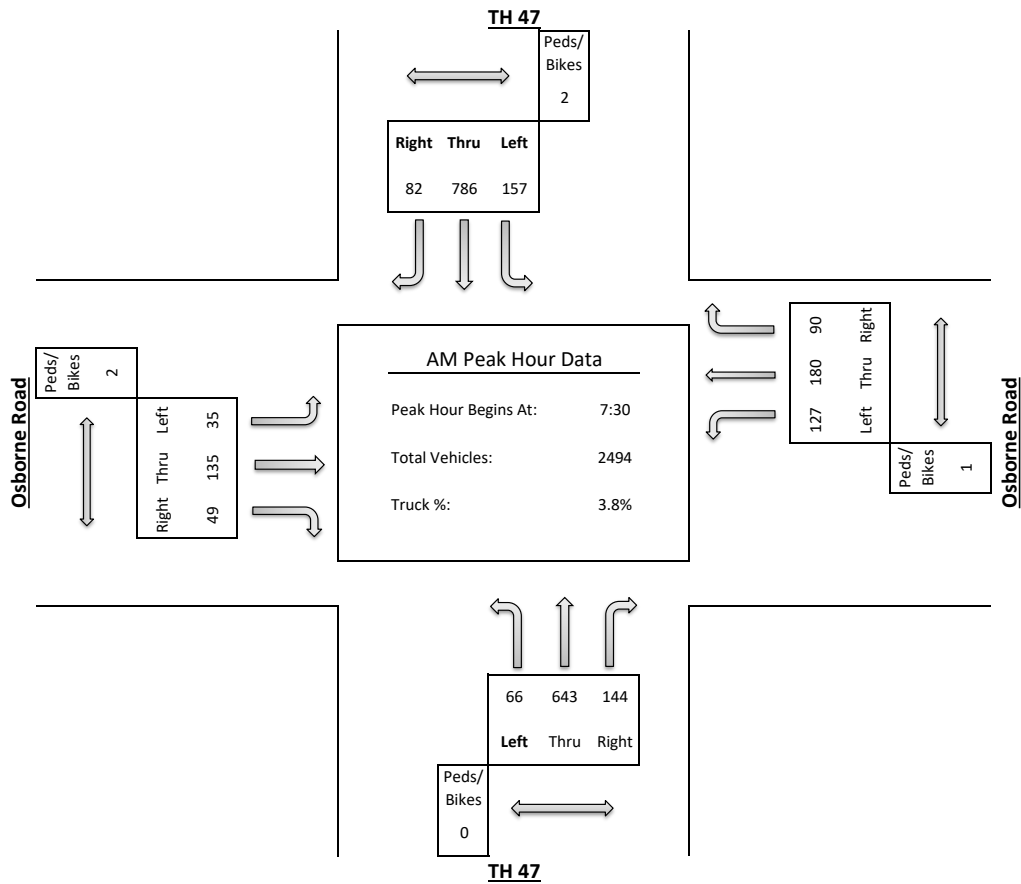

ALLIANT ENGINEERING, INC.

733 S Marquette Ave #700, Minneapolis, MN 55402

Intersection: TH 47 & Osborne Road
 Date: 3/21/2024
 Duration: 0600-1800

Site Code: 613
 Ref Pt: N/A
 Page No: 3 of 4

All Vehicles (Cars & Trucks) Printed

Start Time	TH 47 Southbound						Osborne Road Westbound						TH 47 Northbound						Osborne Road Eastbound						Int. Veh. Total	Int. Ped/Bike Total
	U-Turn	Left	Thru	Right	App. Total	Peds/Bikes	U-Turn	Left	Thru	Right	App. Total	Peds/Bikes	U-Turn	Left	Thru	Right	App. Total	Peds/Bikes	U-Turn	Left	Thru	Right	App. Total	Peds/Bikes		
11:30	1	26	195	19	241	--	1	13	36	23	73	--	--	29	203	14	246	--	--	29	38	17	84	--	644	--
11:45	--	30	170	28	228	--	--	30	52	29	111	--	--	34	186	15	235	--	--	22	34	26	82	--	656	--
12:00	--	19	173	26	218	--	--	24	32	31	87	--	--	26	207	21	254	--	--	31	38	24	93	--	652	--
12:15	--	26	168	30	224	--	--	26	38	27	91	--	--	25	170	17	212	--	--	22	39	18	79	--	606	--
Hour Total	1	101	706	103	911	--	1	93	158	110	362	--	--	114	766	67	947	--	--	104	149	85	338	--	2558	--
% of App.	0.1%	11.1%	77.5%	11.3%			0.3%	25.7%	43.6%	30.4%			0.0%	12.0%	80.9%	7.1%			0.0%	30.8%	44.1%	25.1%				
% of Total	0.0%	3.9%	27.6%	4.0%	35.6%	--	0.0%	3.6%	6.2%	4.3%	14.2%	--	0.0%	4.5%	29.9%	2.6%	37.0%	--	0.0%	4.1%	5.8%	3.3%	13.2%	--		
Cars Total	1	95	690	101	887	--	1	90	154	108	353	--	--	105	746	65	916	--	--	101	145	83	329	--	2485	--
Cars % of Movement	100%	94.1%	97.7%	98.1%	97.4%	--	100%	96.8%	97.5%	98.2%	97.5%	--	0.0%	92.1%	97.4%	97.0%	96.7%	--	0.0%	97.1%	97.3%	97.6%	97.3%	--	97.1%	--
Trucks Total	--	6	16	2	24	--	--	3	4	2	9	--	--	9	20	2	31	--	--	3	4	2	9	--	73	--
Trucks % of Movement	0.0%	5.9%	2.3%	1.9%	2.6%	--	0.0%	3.2%	2.5%	1.8%	2.5%	--	0.0%	7.9%	2.6%	3.0%	3.3%	--	0.0%	2.9%	2.7%	2.4%	2.7%	--	2.9%	--

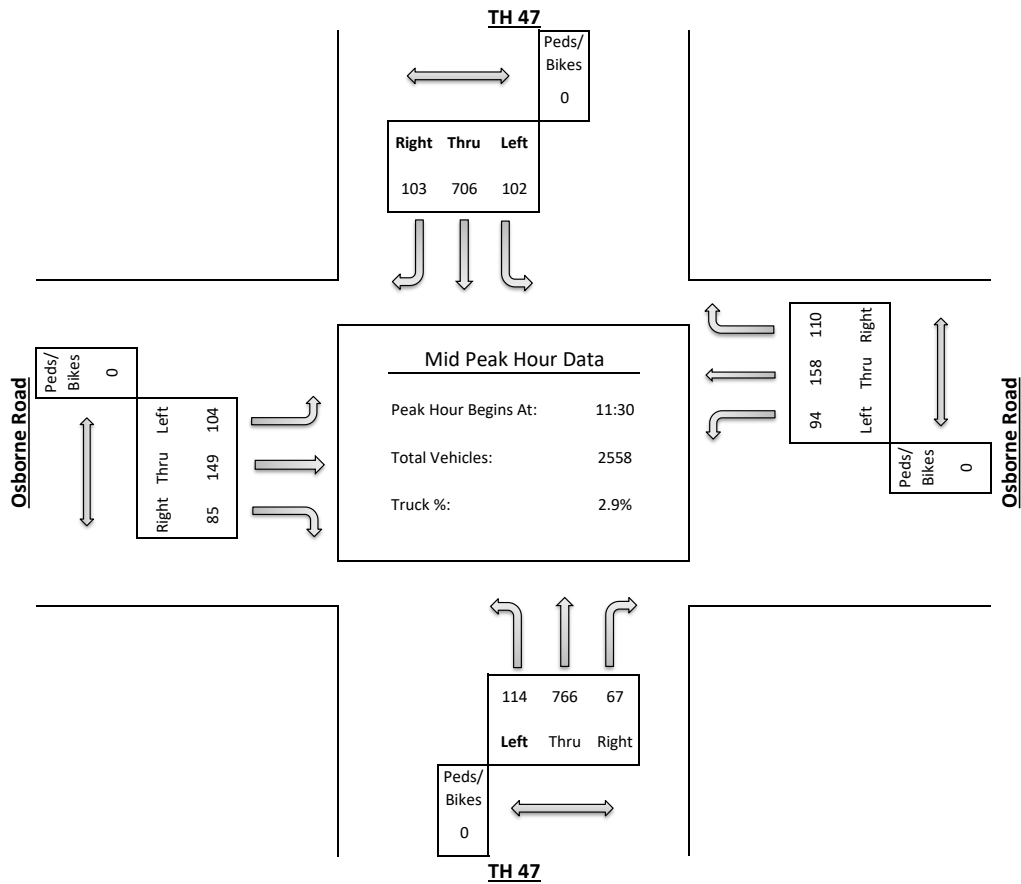

ALLIANT ENGINEERING, INC.

733 S Marquette Ave #700, Minneapolis, MN 55402

Intersection: TH 47 & Osborne Road
 Date: 3/21/2024
 Duration: 0600-1800

Site Code: 613
 Ref Pt: N/A
 Page No: 4 of 4

All Vehicles (Cars & Trucks) Printed

Start Time	TH 47 Southbound						Osborne Road Westbound						TH 47 Northbound						Osborne Road Eastbound						Int. Veh. Total	Int. Ped/Bike Total
	U-Turn	Left	Thru	Right	App. Total	Peds/Bikes	U-Turn	Left	Thru	Right	App. Total	Peds/Bikes	U-Turn	Left	Thru	Right	App. Total	Peds/Bikes	U-Turn	Left	Thru	Right	App. Total	Peds/Bikes		
16:00	--	39	199	12	250	2	--	52	70	61	183	--	--	36	326	22	384	--	--	41	49	21	111	--	928	2
16:15	3	26	195	15	239	--	--	41	54	43	138	--	--	28	295	15	338	--	--	37	54	22	113	--	828	--
16:30	1	14	227	17	259	4	--	35	38	46	119	--	--	23	308	18	349	--	--	42	46	29	117	--	844	4
16:45	--	30	225	16	271	--	--	27	53	45	125	--	--	15	302	17	334	1	--	33	56	24	113	1	843	2
Hour Total	4	109	846	60	1019	6	--	155	215	195	565	--	--	102	1231	72	1405	1	--	153	205	96	454	1	3443	8
% of App.	0.4%	10.7%	83.0%	5.9%			0.0%	27.4%	38.1%	34.5%			0.0%	7.3%	87.6%	5.1%			0.0%	33.7%	45.2%	21.1%				
% of Total	0.1%	3.2%	24.6%	1.7%	29.6%	75.0%	0.0%	4.5%	6.2%	5.7%	16.4%	0.0%	0.0%	3.0%	35.8%	2.1%	40.8%	12.5%	0.0%	4.4%	6.0%	2.8%	13.2%	12.5%		
Cars Total	4	107	828	58	997	4	--	154	212	194	560	--	--	99	1200	70	1369	1	--	152	200	94	446	1	3372	6
Cars % of Movement	100%	98.2%	97.9%	96.7%	97.8%	66.7%	0.0%	99.4%	98.6%	99.5%	99.1%	0.0%	0.0%	97.1%	97.5%	97.2%	97.4%	16.7%	0.0%	99.3%	97.6%	97.9%	98.2%	16.7%	97.9%	
Trucks Total	--	2	18	2	22	2	--	1	3	1	5	--	--	3	31	2	36	--	--	1	5	2	8	--	71	2
Trucks % of Movement	0.0%	1.8%	2.1%	3.3%	2.2%	###	0.0%	0.6%	1.4%	0.5%	0.9%	0.0%	0.0%	2.9%	2.5%	2.8%	2.6%	0.0%	0.0%	0.7%	2.4%	2.1%	1.8%	0.0%	2.1%	

