

ALLIANT ENGINEERING, INC.

733 S Marquette Ave #700, Minneapolis, MN 55402

Intersection: 83rd Avenue & Frontage Road
 Date: 3/21/2024
 Duration: 0600-1800

Site Code: 61452
 Ref Pt: N/A
 Page No: 1 of 4

All Vehicles (Cars & Trucks) Printed

Start Time	Frontage Road Southbound						83rd Avenue Westbound						Frontage Road Northbound						83rd Avenue Eastbound						Int. Veh. Total	Int. Ped/Bike Total	
	U-Turn	Left	Thru	Right	App. Total	Peds/Bikes	U-Turn	Left	Thru	Right	App. Total	Peds/Bikes	U-Turn	Left	Thru	Right	App. Total	Peds/Bikes	U-Turn	Left	Thru	Right	App. Total	Peds/Bikes			
6:00	--	--	1	--	1	--	--	2	2	--	4	--	--	--	--	--	0	--	--	--	2	--	2	--	7	--	
6:15	--	--	--	--	0	--	--	--	3	--	3	--	--	2	--	--	2	--	--	--	3	2	5	--	10	--	
6:30	--	--	2	--	2	--	--	5	5	--	10	--	--	4	1	--	5	--	--	--	6	1	7	--	24	--	
6:45	--	--	1	--	1	1	--	--	5	--	5	--	--	6	1	--	7	--	--	--	2	7	3	12	--	25	1
Hour Total	--	--	4	--	4	1	--	7	15	--	22	--	--	12	2	--	14	--	--	2	18	6	26	--	66	1	
7:00	--	--	1	--	1	--	--	3	4	--	7	--	--	3	--	1	4	--	--	1	7	4	12	--	24	--	
7:15	--	1	2	--	3	--	--	3	2	--	5	--	--	5	1	--	6	--	--	4	11	--	15	--	29	--	
7:30	--	--	4	--	4	--	--	1	9	--	10	--	--	4	1	2	7	--	--	1	9	3	13	--	34	--	
7:45	--	--	--	--	0	--	--	--	6	--	6	--	--	5	--	3	8	--	--	--	6	3	9	--	23	--	
Hour Total	--	1	7	--	8	--	--	7	21	--	28	--	--	17	2	6	25	--	--	6	33	10	49	--	110	--	
8:00	--	--	4	--	4	--	--	1	5	--	6	--	--	8	2	1	11	--	--	2	9	2	13	--	34	--	
8:15	--	1	--	--	1	--	--	3	12	--	15	--	--	8	1	2	11	1	--	2	6	15	23	--	50	1	
8:30	--	--	3	--	3	--	--	3	6	--	9	--	--	5	--	1	6	1	--	3	9	3	15	--	33	1	
8:45	--	--	8	--	8	--	--	1	3	--	4	--	--	2	6	--	8	--	--	5	8	5	18	--	38	--	
Hour Total	--	1	15	--	16	--	--	8	26	--	34	--	--	23	9	4	36	2	--	12	32	25	69	--	155	2	
9:00	--	1	3	1	5	--	--	--	13	--	13	--	--	4	3	2	9	--	--	4	12	8	24	--	51	--	
9:15	--	1	2	3	6	--	--	--	6	--	6	--	--	3	6	1	10	--	--	3	7	7	17	--	39	--	
9:30	--	2	3	1	6	--	--	3	3	1	7	--	--	5	1	1	7	--	--	2	5	6	13	--	33	--	
9:45	--	--	2	1	3	--	--	--	4	1	5	--	--	1	1	1	3	--	--	8	5	11	24	--	35	--	
Hour Total	--	4	10	6	20	--	--	3	26	2	31	--	--	13	11	5	29	--	--	17	29	32	78	--	158	--	
10:00	--	--	7	3	10	--	--	2	4	--	6	--	--	4	8	1	13	--	--	8	7	6	21	--	50	--	
10:15	--	1	3	2	6	--	--	1	1	3	5	--	--	5	2	1	8	--	--	5	8	10	23	--	42	--	
10:30	--	2	6	2	10	--	--	3	3	--	6	--	--	8	3	--	11	--	--	2	6	10	18	--	45	--	
10:45	--	1	8	--	9	1	--	2	6	--	8	--	--	6	2	4	12	--	--	3	12	11	26	--	55	1	
Hour Total	--	4	24	7	35	1	--	8	14	3	25	--	--	23	15	6	44	--	--	18	33	37	88	--	192	1	
11:00	--	--	3	1	4	--	--	2	6	1	9	2	--	6	5	6	17	--	--	4	13	17	34	--	64	2	
11:15	--	3	3	--	6	--	--	1	7	3	11	1	--	6	5	3	14	--	--	5	14	12	31	--	62	1	
11:30	--	2	9	--	11	--	--	3	5	1	9	--	--	7	--	3	10	--	--	2	25	14	41	--	71	--	
11:45	--	3	4	1	8	--	--	8	4	1	13	--	--	6	8	7	21	--	--	6	16	17	39	--	81	--	
Hour Total	--	8	19	2	29	--	--	14	22	6	42	3	--	25	18	19	62	--	--	17	68	60	145	--	278	3	
12:00	--	1	4	--	5	--	--	6	8	2	16	--	--	15	4	4	23	--	--	8	19	23	50	--	94	--	
12:15	--	2	10	2	14	--	--	6	5	3	14	--	--	13	4	1	18	--	--	6	20	9	35	--	81	--	
12:30	--	3	11	1	15	--	--	2	9	1	12	--	--	10	4	4	18	--	--	5	7	10	22	--	67	--	
12:45	--	1	7	2	10	--	--	4	15	4	23	--	--	14	2	3	19	2	--	5	12	15	32	--	84	2	
Hour Total	--	7	32	5	44	--	--	18	37	10	65	--	--	52	14	12	78	2	--	24	58	57	139	--	326	2	
13:00	--	--	6	--	6	--	--	3	7	1	11	--	--	16	6	5	27	--	--	9	12	15	36	--	80	--	
13:15	--	4	7	2	13	--	--	--	3	--	3	--	--	9	3	3	15	--	--	3	8	8	19	--	50	--	
13:30	--	3	9	--	12	--	--	2	4	1	7	--	--	11	5	2	18	--	--	4	18	16	38	--	75	--	
13:45	--	1	4	1	6	--	--	2	5	1	8	--	--	14	4	2	20	--	--	4	14	11	29	--	63	--	
Hour Total	--	8	26	3	37	--	--	7	19	3	29	--	--	50	18	12	80	--	--	20	52	50	122	--	268	--	
14:00	--	1	7	1	9	--	--	1	--	--	1	--	--	8	7	1	16	--	--	7	11	8	26	--	52	--	
14:15	--	4	6	--	10	--	--	1	3	--	4	--	--	8	2	3	13	--	--	2	14	7	23	--	50	--	
14:30	--	1	9	2	12	--	--	1	9	1	11	--	--	10	4	2	16	--	--	5	16	9	30	--	69	--	
14:45	--	1	8	2	11	--	--	2	7	1	10	--	--	3	4	5	12	--	--	7	25	9	41	--	74	--	
Hour Total	--	7	30	5	42	--	--	5	19	2	26	--	--	29	17	11	57	--	--	21	66	33	120	--	245	--	
15:00	--	1	14	--	15	--	--	1	7	4	12	--	--	10	7	6	23	--	--	10	17	8	35	--	85	--	
15:15	--	3	6	3	12	--	--	2	5	2	9	1	--	14	7	4	25	--	--	10	14	5	29	--	75	1	
15:30	--	--	6	1	7	--	--	--	7	3	10	--	--	4	4	3	11	--	--	4	22	9	35	--	63	--	
15:45	--	4	7	1	12	--	--	2	5	1	8	--	--	6	5	2	13	--	--	11	24	16	51	--	84	--	
Hour Total	--	8	33	5	46	--	--	5	24	10	39	1	--	34	23	15	72	--	--	35	77	38	150	--	307	1	
16:00	--	4	11	1	16	--	--	4	15	1	20	--	--	8	7	3	18	--	--	12	19	10	41	--	95	--	
16:15	--	5	9	--	14	--	--	4	13	2	19	--	--	9	6	5	20	--	--	9	17	15	41	--	94	--	
16:30	--	6	4	4	14	--	--	5	10	2	17	--	--	21	9	4	34	--	--	5	12	17	34	--	99	--	
16:45	1	2	4	1	8	--	--	1	3	2	6	--	--	14	5	2	21	--	--	2	20	15	37	--	72	--	
Hour Total	1	17	28	6	52	--	--	14	41	7	62	--	--	52	27	14	93	--	--	28	68	57	153	--	360	--	
17:00	--	4	12	1	17	--	--	1	6	2	9	1	--	12	4	9	25	--	--	7	14	17	38	--	89	1	
17:15	--	2	10	2	14	--	--	--	5	--	5	--	--	20	5	5	30	--	--	4	11	21	36	--	85	--	
17:30	--	2	7	--	9	--	--	1	9	--	10	--	--	13	4	5	22	--	--	5	22	9	36	--	77	--	
17:45	--	3	6	--	9	--	--	--	4	--	4	--	--	6	3	--	9	--	--	9	16	10	35	--	57	--	
Hour Total	--	11	35	3	49	--	--	2	24	2	28	1	--	51	16	19	86	--	--	25	63	57	145	--	308	1	
Grand Total	1	76	263	42	382	2	--	98	288	45	431	5	--	381	172	123	676	4	--	225	597	462	1284	--	2773	11	
% of App.	0.3%	19.9%	68.8%	11.0%			0.0%	22.7%	66.8%	10.4%			0.0%	56.4%	25.4%	18.2%			0.0%	17.5%	46.5%	36.0%					
% of Total	0.0%	2.7%	9.5%	1.5%	13.8%	18.2%	0.0%	3.5%	10.4%	1.6%	15.5%	45.5%	0.0%	13.7%	6.2%	4.4%	24.4%	36.4%	0.0%	8.1%	21.5%	16.7%	46.3%	0.0%			
Cars Total	1	73	260	41	375	2	--	98	287	44	429	5	--	376	169	123	668	4	--	221	587	460	1268	--	2740	11	
Cars % of Movement	100%	96.1%	98.9%	97.6%	98.2%	18.2%	0.0%	100%	99.7%	97.8%	99.5%	45.5%	0.0%	98.7%	98.3%	100%	98.8%	36.4%	0.0%	98.2%	98.3%	99.6%	98.8%	0.0%		98.8%	
Trucks Total	--	3	3	1	7	--	--	--	1	1	2	--	--	5	3	--	8	--	--	4	10	2	16	--	33	--	
Trucks % of Movement	0.0%	3.9%	1.1%	2.4%	1.8%	--	0.0%	0.0%	0.3%	2.2%	0.5%	--	0.0%	1.3%	1.7%	0.0%	1.2%	--	0.0%	1.8%	1.7%	0.4%	1.2%	--		1.2%	

ALLIANT ENGINEERING, INC.

733 S Marquette Ave #700, Minneapolis, MN 55402

Intersection: 83rd Avenue & Frontage Road
 Date: 3/21/2024
 Duration: 0600-1800

Site Code: 61452
 Ref Pt: N/A
 Page No: 2 of 4

All Vehicles (Cars & Trucks) Printed

Start Time	Frontage Road Southbound						83rd Avenue Westbound						Frontage Road Northbound						83rd Avenue Eastbound						Int. Veh. Total	Int. Ped/Bike Total
	U-Turn	Left	Thru	Right	App. Total	Peds/Bikes	U-Turn	Left	Thru	Right	App. Total	Peds/Bikes	U-Turn	Left	Thru	Right	App. Total	Peds/Bikes	U-Turn	Left	Thru	Right	App. Total	Peds/Bikes		
8:15	--	1	--	--	1	--	--	3	12	--	15	--	--	8	1	2	11	1	--	2	6	15	23	--	50	1
8:30	--	--	3	--	3	--	--	3	6	--	9	--	--	5	--	1	6	1	--	3	9	3	15	--	33	1
8:45	--	--	8	--	8	--	--	1	3	--	4	--	--	2	6	--	8	--	--	5	8	5	18	--	38	--
9:00	--	1	3	1	5	--	--	--	13	--	13	--	--	4	3	2	9	--	--	4	12	8	24	--	51	--
Hour Total	--	2	14	1	17	--	--	7	34	--	41	--	--	19	10	5	34	2	--	14	35	31	80	--	172	2
% of App.	0.0%	11.8%	82.4%	5.9%			0.0%	17.1%	82.9%	0.0%			0.0%	55.9%	29.4%	14.7%			0.0%	17.5%	43.8%	38.8%				
% of Total	0.0%	1.2%	8.1%	0.6%	9.9%	0.0%	0.0%	4.1%	19.8%	0.0%	23.8%	0.0%	0.0%	11.0%	5.8%	2.9%	19.8%	#####	0.0%	8.1%	20.3%	18.0%	46.5%	0.0%		
Cars Total	--	1	13	--	14	--	--	7	34	--	41	--	--	19	10	5	34	2	--	12	34	31	77	--	166	2
Cars % of Movement	0.0%	50.0%	92.9%	0.0%	82.4%	0.0%	0.0%	100%	100%	0.0%	100%	0.0%	0.0%	100%	100%	100%	100%	#####	0.0%	85.7%	97.1%	100%	96.3%	0.0%	96.5%	
Trucks Total	--	1	1	1	3	--	--	--	--	--	0	--	--	--	--	--	0	--	--	2	1	--	3	--	6	--
Trucks % of Movement	0.0%	50.0%	7.1%	100%	17.6%	--	0.0%	0.0%	0.0%	0.0%	0.0%	--	0.0%	0.0%	0.0%	0.0%	0.0%	--	0.0%	14.3%	2.9%	0.0%	3.8%	--	3.5%	

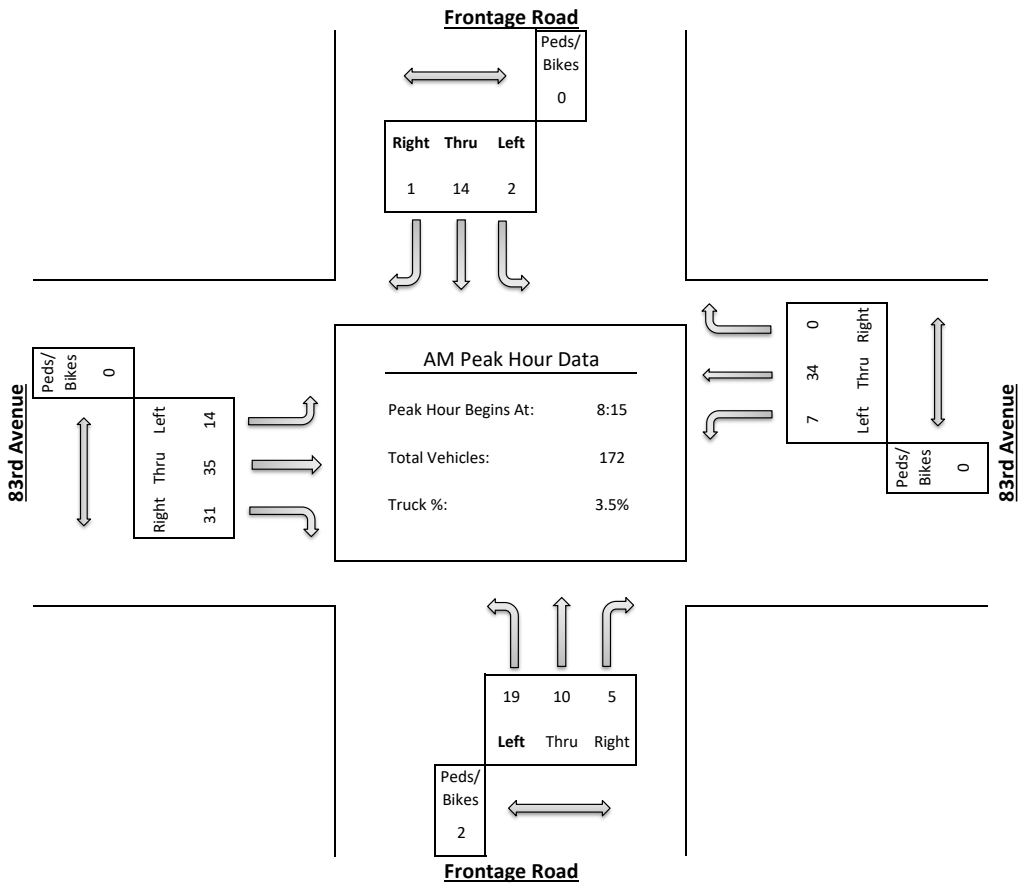

ALLIANT ENGINEERING, INC.

733 S Marquette Ave #700, Minneapolis, MN 55402

Intersection: 83rd Avenue & Frontage Road
 Date: 3/21/2024
 Duration: 0600-1800

Site Code: 61452
 Ref Pt: N/A
 Page No: 3 of 4

All Vehicles (Cars & Trucks) Printed

Start Time	Frontage Road Southbound						83rd Avenue Westbound						Frontage Road Northbound						83rd Avenue Eastbound						Int. Veh. Total	Int. Ped/Bike Total
	U-Turn	Left	Thru	Right	App. Total	Peds/Bikes	U-Turn	Left	Thru	Right	App. Total	Peds/Bikes	U-Turn	Left	Thru	Right	App. Total	Peds/Bikes	U-Turn	Left	Thru	Right	App. Total	Peds/Bikes		
11:30	--	2	9	--	11	--	--	3	5	1	9	--	--	7	--	3	10	--	--	2	25	14	41	--	71	--
11:45	--	3	4	1	8	--	--	8	4	1	13	--	--	6	8	7	21	--	--	6	16	17	39	--	81	--
12:00	--	1	4	--	5	--	--	6	8	2	16	--	--	15	4	4	23	--	--	8	19	23	50	--	94	--
12:15	--	2	10	2	14	--	--	6	5	3	14	--	--	13	4	1	18	--	--	6	20	9	35	--	81	--
Hour Total	--	8	27	3	38	--	--	23	22	7	52	--	--	41	16	15	72	--	--	22	80	63	165	--	327	--
% of App.	0.0%	21.1%	71.1%	7.9%			0.0%	44.2%	42.3%	13.5%			0.0%	56.9%	22.2%	20.8%			0.0%	13.3%	48.5%	38.2%				
% of Total	0.0%	2.4%	8.3%	0.9%	11.6%	--	0.0%	7.0%	6.7%	2.1%	15.9%	--	0.0%	12.5%	4.9%	4.6%	22.0%	--	0.0%	6.7%	24.5%	19.3%	50.5%	--		
Cars Total	--	7	27	3	37	--	--	23	22	7	52	--	--	39	15	15	69	--	--	22	79	62	163	--	321	--
Cars % of Movement	0.0%	87.5%	100%	100%	97.4%	--	0.0%	100%	100%	100%	100%	--	0.0%	95.1%	93.8%	100%	95.8%	--	0.0%	100%	98.8%	98.4%	98.8%	--	98.2%	--
Trucks Total	--	1	--	--	1	--	--	--	--	--	0	--	--	2	1	--	3	--	--	--	1	1	2	--	6	--
Trucks % of Movement	0.0%	12.5%	0.0%	0.0%	2.6%	--	0.0%	0.0%	0.0%	0.0%	0.0%	--	0.0%	4.9%	6.3%	0.0%	4.2%	--	0.0%	0.0%	1.3%	1.6%	1.2%	--	1.8%	--

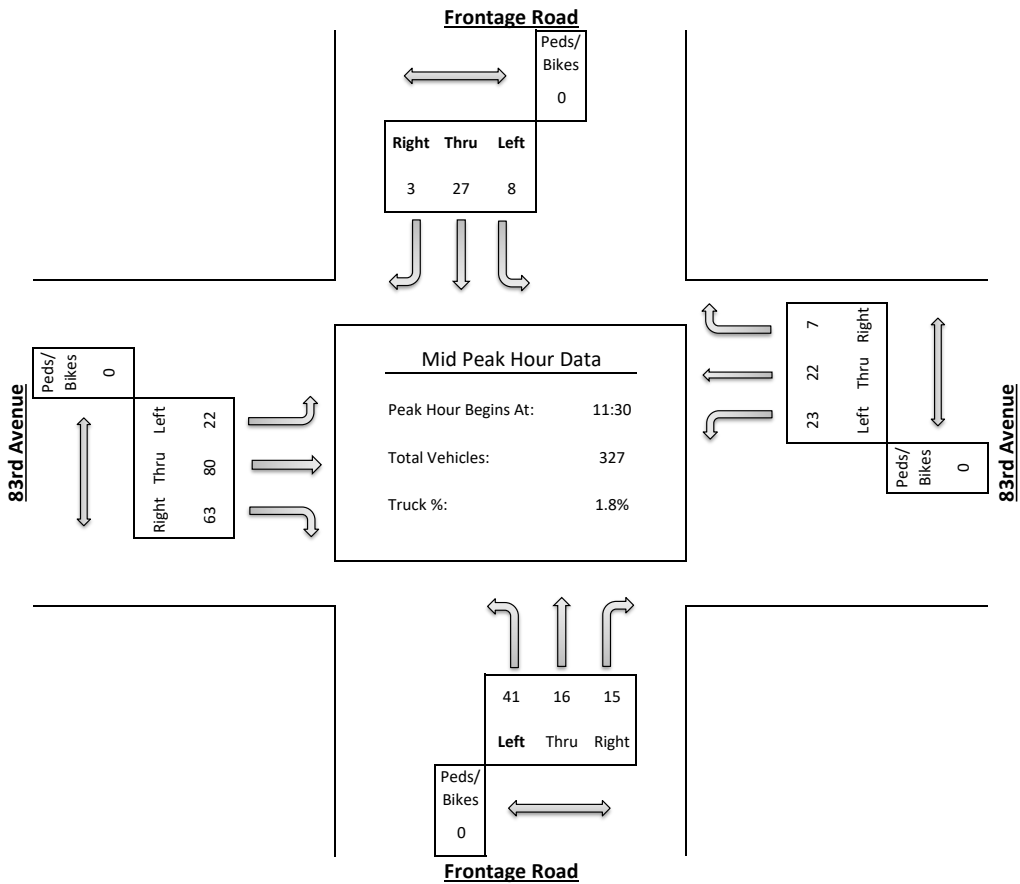

ALLIANT ENGINEERING, INC.

733 S Marquette Ave #700, Minneapolis, MN 55402

Intersection: 83rd Avenue & Frontage Road
 Date: 3/21/2024
 Duration: 0600-1800

Site Code: 61452
 Ref Pt: N/A
 Page No: 4 of 4

All Vehicles (Cars & Trucks) Printed

Start Time	Frontage Road Southbound						83rd Avenue Westbound						Frontage Road Northbound						83rd Avenue Eastbound						Int. Veh. Total	Int. Ped/Bike Total
	U-Turn	Left	Thru	Right	App. Total	Peds/Bikes	U-Turn	Left	Thru	Right	App. Total	Peds/Bikes	U-Turn	Left	Thru	Right	App. Total	Peds/Bikes	U-Turn	Left	Thru	Right	App. Total	Peds/Bikes		
15:45	--	4	7	1	12	--	--	2	5	1	8	--	--	6	5	2	13	--	--	11	24	16	51	--	84	--
16:00	--	4	11	1	16	--	--	4	15	1	20	--	--	8	7	3	18	--	--	12	19	10	41	--	95	--
16:15	--	5	9	--	14	--	--	4	13	2	19	--	--	9	6	5	20	--	--	9	17	15	41	--	94	--
16:30	--	6	4	4	14	--	--	5	10	2	17	--	--	21	9	4	34	--	--	5	12	17	34	--	99	--
Hour Total	--	19	31	6	56	--	--	15	43	6	64	--	--	44	27	14	85	--	--	37	72	58	167	--	372	--
% of App.	0.0%	33.9%	55.4%	10.7%			0.0%	23.4%	67.2%	9.4%			0.0%	51.8%	31.8%	16.5%			0.0%	22.2%	43.1%	34.7%				
% of Total	0.0%	5.1%	8.3%	1.6%	15.1%	--	0.0%	4.0%	11.6%	1.6%	17.2%	--	0.0%	11.8%	7.3%	3.8%	22.8%	--	0.0%	9.9%	19.4%	15.6%	44.9%	--		
Cars Total	--	18	31	6	55	--	--	15	42	6	63	--	--	44	27	14	85	--	--	37	72	58	167	--	370	--
Cars % of Movement	0.0%	94.7%	100%	100%	98.2%	--	0.0%	100%	97.7%	100%	98.4%	--	0.0%	100%	100%	100%	100%	--	0.0%	100%	100%	100%	100%	--	99.5%	--
Trucks Total	--	1	--	--	1	--	--	--	1	--	1	--	--	--	--	--	0	--	--	--	--	--	0	--	2	--
Trucks % of Movement	0.0%	5.3%	0.0%	0.0%	1.8%	--	0.0%	0.0%	2.3%	0.0%	1.6%	--	0.0%	0.0%	0.0%	0.0%	0.0%	--	0.0%	0.0%	0.0%	0.0%	0.0%	--	0.5%	--

