



# MINNESOTA DEPT OF TRANSPORTATION

## TRAFFIC DATA COLLECTION - METRO

Loc: TH 47 @ BUNKER LAKE RD 2006    File Name : TH 47 AT CSAH 116-BUNKER LAKE RD 2006  
 REF. PT.: 022+00.200                      Site Code : 00000000  
 JAMAR#T-1385/MAR/DR                    Start Date : 10/31/2006  
 TURN MOVEMENT COUNT                    Page No : 1

**Groups Printed- CARS & TRUCKS**

Start Time	TH 47 Southbound				CSAH 116/BUNKER LAKE RD Westbound				TH 47 Northbound				CSAH 116/BUNKER LAKE RD Eastbound				Int. Total
	Left	Thru	Right	Peds	Left	Thru	Right	Peds	Left	Thru	Right	Peds	Left	Thru	Right	Peds	
06:00	59	239	8	0	3	26	7	0	10	12	3	0	6	39	17	0	429
06:15	117	219	8	0	9	75	13	0	6	46	5	0	6	38	16	0	558
06:30	133	222	7	0	7	82	17	0	9	39	9	0	9	86	21	0	641
06:45	149	196	10	0	8	107	26	0	12	30	17	0	6	93	22	0	676
<b>Total</b>	<b>458</b>	<b>876</b>	<b>33</b>	<b>0</b>	<b>27</b>	<b>290</b>	<b>63</b>	<b>0</b>	<b>37</b>	<b>127</b>	<b>34</b>	<b>0</b>	<b>27</b>	<b>256</b>	<b>76</b>	<b>0</b>	<b>2304</b>
07:00	179	193	2	0	24	62	34	0	11	20	23	0	5	130	29	2	714
07:15	168	171	9	0	34	92	29	0	11	50	26	0	11	182	49	0	832
07:30	112	218	7	0	21	150	45	0	22	50	11	0	9	104	33	0	782
07:45	113	195	13	0	17	163	26	0	14	57	8	0	12	67	32	0	717
<b>Total</b>	<b>572</b>	<b>777</b>	<b>31</b>	<b>0</b>	<b>96</b>	<b>467</b>	<b>134</b>	<b>0</b>	<b>58</b>	<b>177</b>	<b>68</b>	<b>0</b>	<b>37</b>	<b>483</b>	<b>143</b>	<b>2</b>	<b>3045</b>
08:00	70	176	7	0	16	84	43	0	17	67	16	0	16	38	14	0	564
08:15	57	163	14	0	10	60	38	0	15	73	6	0	9	38	18	0	501
08:30	61	166	7	0	13	47	40	1	25	46	3	0	21	38	19	0	487
08:45	73	167	12	0	17	58	31	0	14	67	14	0	13	36	11	0	513
<b>Total</b>	<b>261</b>	<b>672</b>	<b>40</b>	<b>0</b>	<b>56</b>	<b>249</b>	<b>152</b>	<b>1</b>	<b>71</b>	<b>253</b>	<b>39</b>	<b>0</b>	<b>59</b>	<b>150</b>	<b>62</b>	<b>0</b>	<b>2065</b>
15:00	48	69	9	0	18	132	141	0	16	184	25	1	33	90	18	0	784
15:15	35	102	7	0	20	87	140	0	28	187	19	0	20	61	14	0	720
15:30	45	102	5	0	18	80	141	0	16	175	22	0	30	135	32	0	801
15:45	79	102	6	0	22	172	197	0	19	192	13	0	23	86	15	0	926
<b>Total</b>	<b>207</b>	<b>375</b>	<b>27</b>	<b>0</b>	<b>78</b>	<b>471</b>	<b>619</b>	<b>0</b>	<b>79</b>	<b>738</b>	<b>79</b>	<b>1</b>	<b>106</b>	<b>372</b>	<b>79</b>	<b>0</b>	<b>3231</b>
16:00	44	112	13	0	21	109	166	0	28	178	9	6	52	106	17	0	861
16:15	60	103	10	0	24	151	196	0	26	193	21	2	36	74	18	0	914
16:30	80	87	17	0	21	134	198	0	22	168	14	5	40	146	25	5	962
16:45	68	114	13	0	18	159	189	0	20	194	22	0	35	89	22	1	944
<b>Total</b>	<b>252</b>	<b>416</b>	<b>53</b>	<b>0</b>	<b>84</b>	<b>553</b>	<b>749</b>	<b>0</b>	<b>96</b>	<b>733</b>	<b>66</b>	<b>13</b>	<b>163</b>	<b>415</b>	<b>82</b>	<b>6</b>	<b>3681</b>
17:00	62	108	15	0	19	117	203	0	14	190	8	0	36	111	23	0	906
17:15	61	109	5	0	21	146	234	0	19	183	10	0	34	79	15	0	916
17:30	77	132	9	0	13	135	188	0	14	219	12	0	37	93	14	0	943
17:45	76	138	9	0	42	148	212	0	18	186	15	0	32	61	14	0	951
<b>Total</b>	<b>276</b>	<b>487</b>	<b>38</b>	<b>0</b>	<b>95</b>	<b>546</b>	<b>837</b>	<b>0</b>	<b>65</b>	<b>778</b>	<b>45</b>	<b>0</b>	<b>139</b>	<b>344</b>	<b>66</b>	<b>0</b>	<b>3716</b>
<b>Grand Total</b>	<b>2026</b>	<b>3603</b>	<b>222</b>	<b>0</b>	<b>436</b>	<b>2576</b>	<b>2554</b>	<b>1</b>	<b>406</b>	<b>2806</b>	<b>331</b>	<b>14</b>	<b>531</b>	<b>2020</b>	<b>508</b>	<b>8</b>	<b>18042</b>
Apprch %	34.6	61.6	3.8	0	7.8	46.3	45.9	0	11.4	78.9	9.3	0.4	17.3	65.9	16.6	0.3	
Total %	11.2	20	1.2	0	2.4	14.3	14.2	0	2.3	15.6	1.8	0.1	2.9	11.2	2.8	0	



# MINNESOTA DEPT OF TRANSPORTATION

## TRAFFIC DATA COLLECTION - METRO

File Name : TH 47 AT CSAH 116-BUNKER LAKE RD 2006  
 Site Code : 00000000  
 Start Date : 10/31/2006  
 Page No : 2

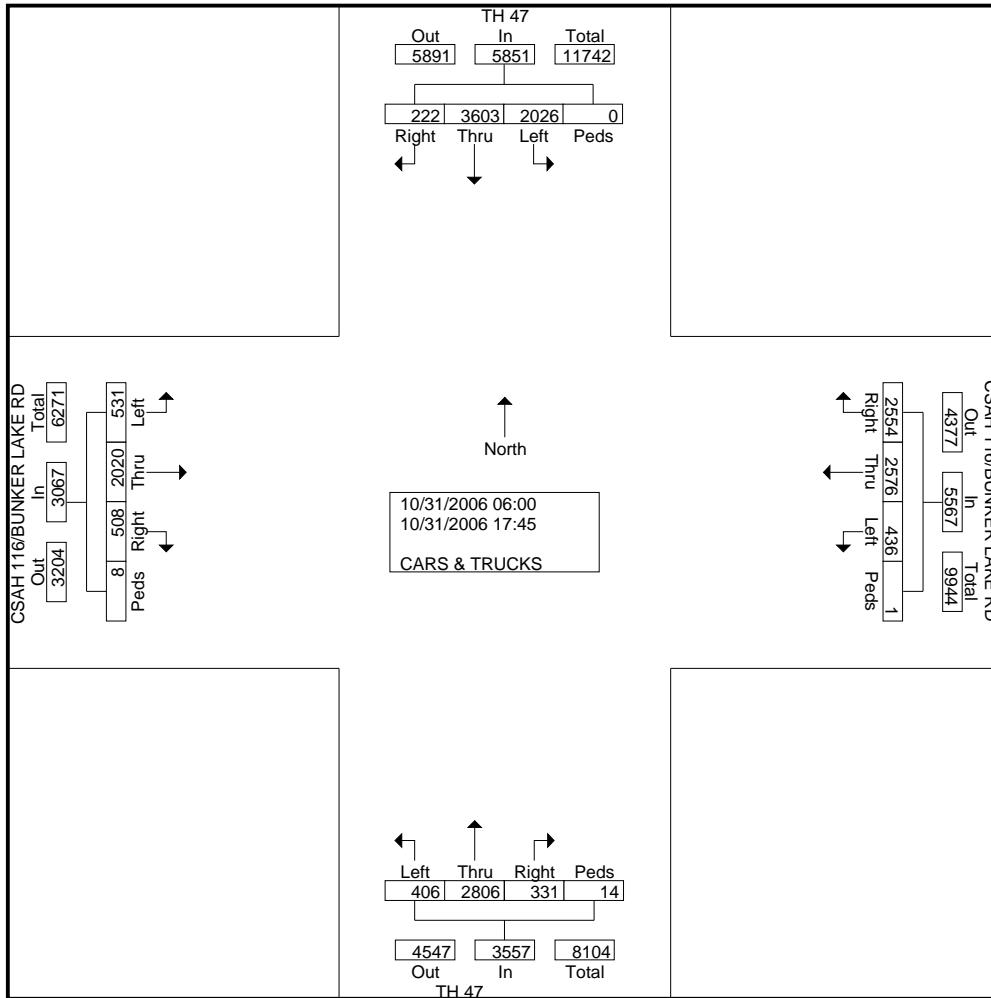



# MINNESOTA DEPT OF TRANSPORTATION

## TRAFFIC DATA COLLECTION - METRO

File Name : TH 47 AT CSAH 116-BUNKER LAKE RD 2006  
 Site Code : 00000000  
 Start Date : 10/31/2006  
 Page No : 3

Start Time	TH 47 Southbound					CSAH 116/BUNKER LAKE RD Westbound					TH 47 Northbound					CSAH 116/BUNKER LAKE RD Eastbound					Int. Total
	Left	Thru	Right	Peds	App. Total	Left	Thru	Right	Peds	App. Total	Left	Thru	Right	Peds	App. Total	Left	Thru	Right	Peds	App. Total	
Peak Hour Analysis From 06:00 to 12:00 - Peak 1 of 1																					
Peak Hour for Entire Intersection Begins at 07:00																					
07:00	179	193	2	0	374	24	62	34	0	120	11	20	23	0	54	5	130	29	2	166	714
07:15	168	171	9	0	348	34	92	29	0	155	11	50	26	0	87	11	182	49	0	242	832
07:30	112	218	7	0	337	21	150	45	0	216	22	50	11	0	83	9	104	33	0	146	782
07:45	113	195	13	0	321	17	163	26	0	206	14	57	8	0	79	12	67	32	0	111	717
Total Volume	572	777	31	0	1380	96	467	134	0	697	58	177	68	0	303	37	483	143	2	665	3045
% App. Total	41.4	56.3	2.2	0		13.8	67	19.2	0		19.1	58.4	22.4	0		5.6	72.6	21.5	0.3		
PHF	.799	.891	.596	.000	.922	.706	.716	.744	.000	.807	.659	.776	.654	.000	.871	.771	.663	.730	.250	.687	.915

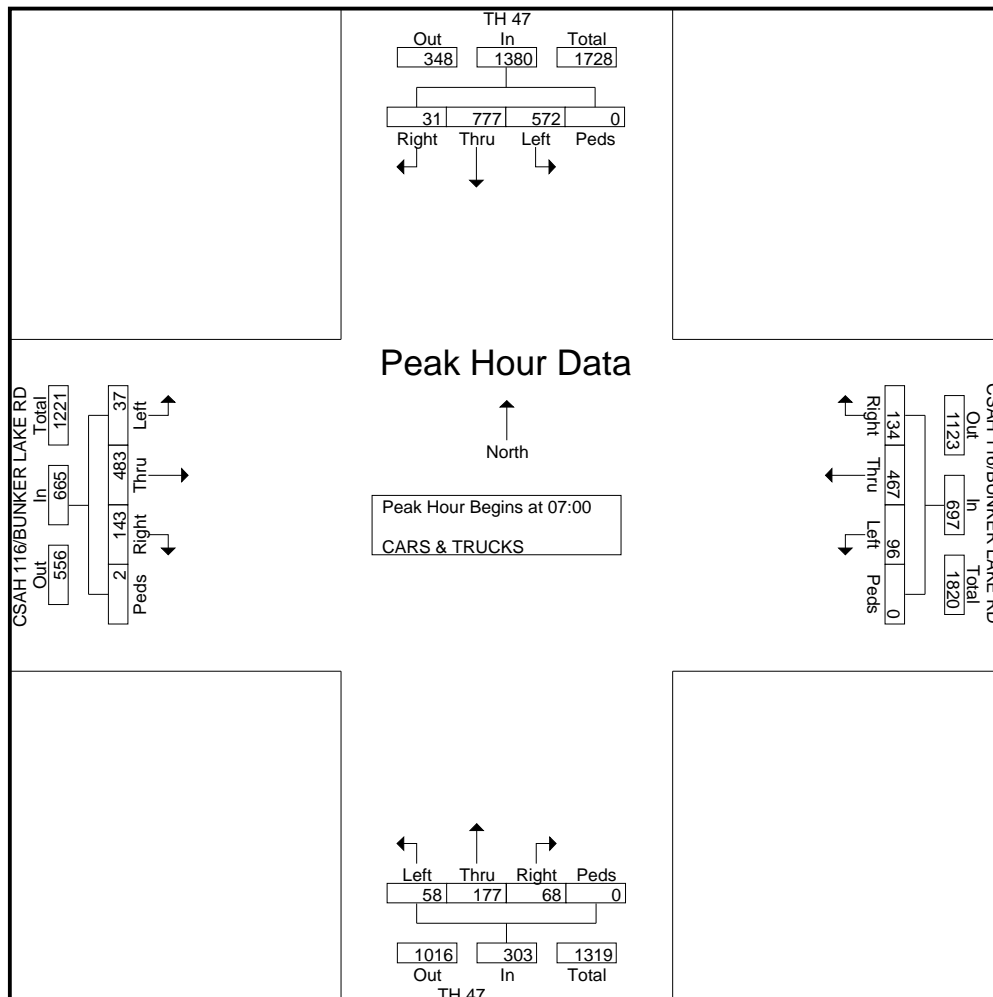



# MINNESOTA DEPT OF TRANSPORTATION

## TRAFFIC DATA COLLECTION - METRO

File Name : TH 47 AT CSAH 116-BUNKER LAKE RD 2006  
 Site Code : 00000000  
 Start Date : 10/31/2006  
 Page No : 4

Start Time	TH 47 Southbound					CSAH 116/BUNKER LAKE RD Westbound					TH 47 Northbound					CSAH 116/BUNKER LAKE RD Eastbound					Int. Total
	Left	Thru	Right	Peds	App. Total	Left	Thru	Right	Peds	App. Total	Left	Thru	Right	Peds	App. Total	Left	Thru	Right	Peds	App. Total	
Peak Hour Analysis From 12:15 to 17:45 - Peak 1 of 1																					
Peak Hour for Entire Intersection Begins at 16:30																					
16:30	80	87	17	0	184	21	134	198	0	353	22	168	14	5	209	40	146	25	5	216	962
16:45	68	114	13	0	195	18	159	189	0	366	20	194	22	0	236	35	89	22	1	147	944
17:00	62	108	15	0	185	19	117	203	0	339	14	190	8	0	212	36	111	23	0	170	906
17:15	61	109	5	0	175	21	146	234	0	401	19	183	10	0	212	34	79	15	0	128	916
Total Volume	271	418	50	0	739	79	556	824	0	1459	75	735	54	5	869	145	425	85	6	661	3728
% App. Total	36.7	56.6	6.8	0		5.4	38.1	56.5	0		8.6	84.6	6.2	0.6		21.9	64.3	12.9	0.9		
PHF	.847	.917	.735	.000	.947	.940	.874	.880	.000	.910	.852	.947	.614	.250	.921	.906	.728	.850	.300	.765	.969

