



MINNESOTA DEPT OF TRANSPORTATION

TRAFFIC DATA COLLECTION - METRO

TH-47 at Co.Rd.81 / Pederson Drive
 Ref.Pt.: 034.802
 JAMAR # D4-3365 CH
 TURN MOVEMENT COUNT

File Name : TH-47 at CR81 Pederson Dr 2009
 Site Code : 00000000
 Start Date : 7/29/2009
 Page No : 1

Groups Printed- Cars & Trucks

Start Time	TH-47 Southbound				Pederson Drive / Co.Rd.81 Westbound				TH-47 Northbound				Pederson Drive / Co.Rd.81 Eastbound				Int. Total
	Left	Thru	Right	Peds	Left	Thru	Right	Peds	Left	Thru	Right	Peds	Left	Thru	Right	Peds	
06:00	0	97	15	0	0	0	0	0	6	5	0	0	2	0	54	0	179
06:15	0	81	16	0	0	0	0	2	10	11	1	0	1	3	64	0	189
06:30	0	105	13	1	0	0	1	4	7	13	0	2	2	1	55	0	204
06:45	2	70	9	0	2	2	0	0	12	22	3	0	4	0	43	0	169
Total	2	353	53	1	2	2	1	6	35	51	4	2	9	4	216	0	741
07:00	1	77	11	0	1	1	2	1	12	19	0	1	5	1	48	0	180
07:15	1	68	13	0	0	1	0	3	24	21	2	0	3	1	61	0	198
07:30	0	44	15	0	1	3	0	6	22	19	2	0	6	2	46	0	166
07:45	4	65	5	0	0	3	2	0	13	20	5	1	4	3	44	0	169
Total	6	254	44	0	2	8	4	10	71	79	9	2	18	7	199	0	713
08:00	0	52	15	0	0	1	0	3	17	19	1	0	5	1	37	0	151
08:15	0	37	11	0	0	1	0	0	18	14	4	0	2	1	39	0	127
08:30	0	40	10	0	0	1	1	0	17	16	1	0	2	2	36	0	126
08:45	0	42	11	0	3	4	0	1	21	15	1	0	5	5	33	0	141
Total	0	171	47	0	3	7	1	4	73	64	7	0	14	9	145	0	545
15:00	4	28	18	0	0	1	0	6	52	57	0	0	12	0	32	0	210
15:15	0	21	18	0	0	2	1	0	66	76	0	0	14	0	29	0	227
15:30	0	16	5	0	1	1	3	5	47	53	0	0	10	0	33	0	174
15:45	0	25	18	0	0	3	0	2	86	99	1	2	15	0	40	0	291
Total	4	90	59	0	1	7	4	13	251	285	1	2	51	0	134	0	902
16:00	0	40	6	0	0	2	0	3	83	77	0	0	14	1	36	0	262
16:15	0	31	13	0	0	1	0	3	90	74	0	0	16	0	35	0	263
16:30	1	33	10	0	0	3	1	0	97	93	0	0	26	1	59	0	324
16:45	1	23	11	0	0	1	0	4	119	79	1	2	33	2	44	0	320
Total	2	127	40	0	0	7	1	10	389	323	1	2	89	4	174	0	1169
17:00	0	42	14	0	2	0	0	0	84	95	0	0	14	0	49	0	300
17:15	0	30	9	0	0	0	1	7	103	98	0	2	18	1	42	0	311
17:30	0	32	20	0	0	2	0	1	85	89	1	0	14	1	53	0	298
17:45	0	42	18	0	1	1	0	2	92	88	0	1	15	1	54	0	315
Total	0	146	61	0	3	3	1	10	364	370	1	3	61	3	198	0	1224
Grand Total	14	1141	304	1	11	34	12	53	1183	1172	23	11	242	27	1066	0	5294
Apprch %	1	78.2	20.8	0.1	10	30.9	10.9	48.2	49.5	49.1	1	0.5	18.1	2	79.9	0	
Total %	0.3	21.6	5.7	0	0.2	0.6	0.2	1	22.3	22.1	0.4	0.2	4.6	0.5	20.1	0	



MINNESOTA DEPT OF TRANSPORTATION

TRAFFIC DATA COLLECTION - METRO

TH-47 at Co.Rd.81 / Pederson Drive
 Ref.Pt.: 034.802
 JAMAR # D4-3365 CH
 TURN MOVEMENT COUNT

File Name : TH-47 at CR81 Pederson Dr 2009
 Site Code : 00000000
 Start Date : 7/29/2009
 Page No : 2

Start Time	TH-47 Southbound					Pederson Drive / Co.Rd.81 Westbound					TH-47 Northbound					Pederson Drive / Co.Rd.81 Eastbound					Int. Total
	Left	Thru	Right	Peds	App. Total	Left	Thru	Right	Peds	App. Total	Left	Thru	Right	Peds	App. Total	Left	Thru	Right	Peds	App. Total	
Peak Hour Analysis From 06:00 to 08:45 - Peak 1 of 1																					
Peak Hour for Entire Intersection Begins at 06:30																					
06:30	0	105	13	1	119	0	0	1	4	5	7	13	0	2	22	2	1	55	0	58	204
06:45	2	70	9	0	81	2	2	0	0	4	12	22	3	0	37	4	0	43	0	47	169
07:00	1	77	11	0	89	1	1	2	1	5	12	19	0	1	32	5	1	48	0	54	180
07:15	1	68	13	0	82	0	1	0	3	4	24	21	2	0	47	3	1	61	0	65	198
Total Volume	4	320	46	1	371	3	4	3	8	18	55	75	5	3	138	14	3	207	0	224	751
% App. Total	1.1	86.3	12.4	0.3		16.7	22.2	16.7	44.4		39.9	54.3	3.6	2.2		6.2	1.3	92.4	0		
PHF	.500	.762	.885	.250	.779	.375	.500	.375	.500	.900	.573	.852	.417	.375	.734	.700	.750	.848	.000	.862	.920

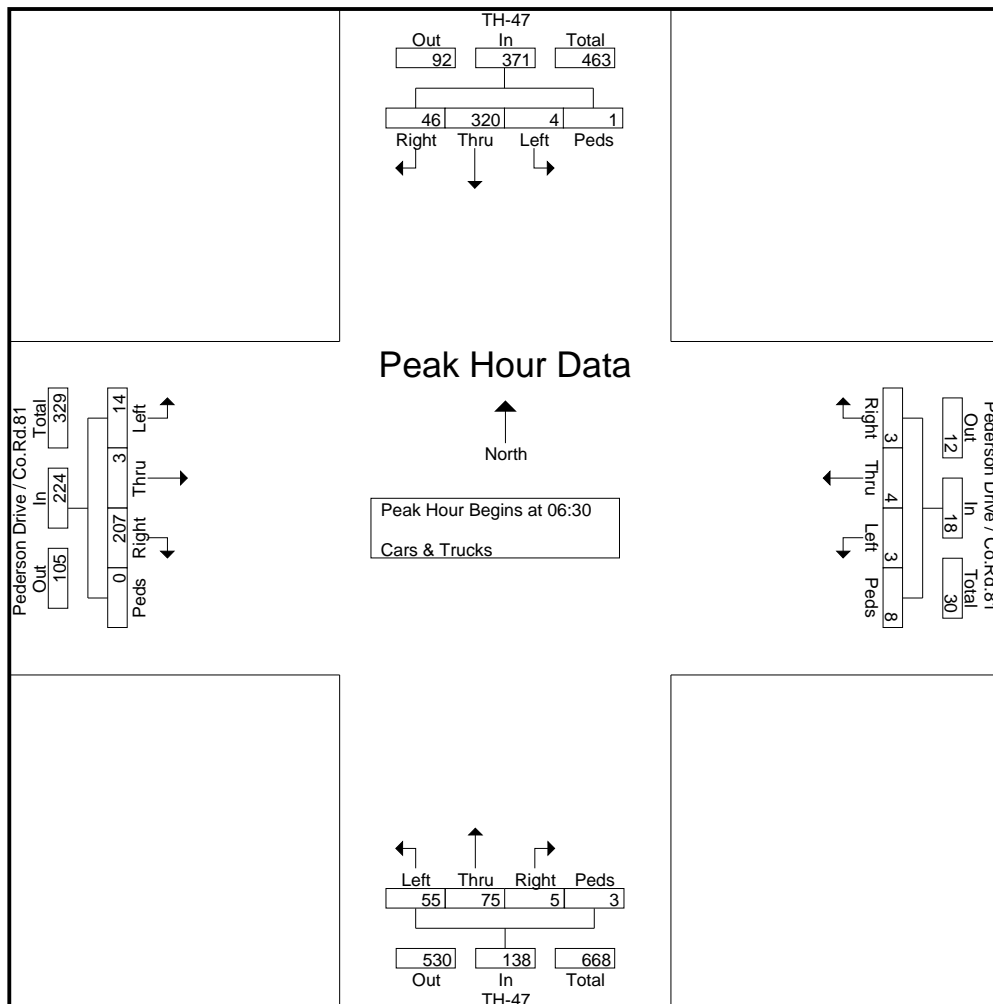



MINNESOTA DEPT OF TRANSPORTATION

TRAFFIC DATA COLLECTION - METRO

TH-47 at Co.Rd.81 / Pederson Drive
 Ref.Pt.: 034.802
 JAMAR # D4-3365 CH
 TURN MOVEMENT COUNT

File Name : TH-47 at CR81 Pederson Dr 2009
 Site Code : 00000000
 Start Date : 7/29/2009
 Page No : 3

Start Time	TH-47 Southbound					Pederson Drive / Co.Rd.81 Westbound					TH-47 Northbound					Pederson Drive / Co.Rd.81 Eastbound					Int. Total
	Left	Thru	Right	Peds	App. Total	Left	Thru	Right	Peds	App. Total	Left	Thru	Right	Peds	App. Total	Left	Thru	Right	Peds	App. Total	
Peak Hour Analysis From 15:00 to 17:45 - Peak 1 of 1																					
Peak Hour for Entire Intersection Begins at 16:30																					
16:30	1	33	10	0	44	0	3	1	0	4	97	93	0	0	190	26	1	59	0	86	324
16:45	1	23	11	0	35	0	1	0	4	5	119	79	1	2	201	33	2	44	0	79	320
17:00	0	42	14	0	56	2	0	0	0	2	84	95	0	0	179	14	0	49	0	63	300
17:15	0	30	9	0	39	0	0	1	7	8	103	98	0	2	203	18	1	42	0	61	311
Total Volume	2	128	44	0	174	2	4	2	11	19	403	365	1	4	773	91	4	194	0	289	1255
% App. Total	1.1	73.6	25.3	0		10.5	21.1	10.5	57.9		52.1	47.2	0.1	0.5		31.5	1.4	67.1	0		
PHF	.500	.762	.786	.000	.777	.250	.333	.500	.393	.594	.847	.931	.250	.500	.952	.689	.500	.822	.000	.840	.968

