

# TRAFFIC DATA INC.

3268 Xenwood Ave S  
St Louis Park, MN 55416

TH-5 at CSAH-59 / Main St E WACONIA

Ref.Pt.: 033.022

TDI Inc

TURN MOVEMENT COUNT

File Name : 2681116 Hwy 5 & CR 59

Site Code : 2681116

Start Date : 2/16/2011

Page No : 1

Groups Printed- Class 1

| Start Time | Co.Rd.59 / Main St E Southbound |      |       |      | TH-5 Westbound |      |       |      | Co.Rd.59 / Main St E Northbound |      |       |      | TH-5 Eastbound |      |       |      | Int. Total |
|------------|---------------------------------|------|-------|------|----------------|------|-------|------|---------------------------------|------|-------|------|----------------|------|-------|------|------------|
|            | Left                            | Thru | Right | Peds | Left           | Thru | Right | Peds | Left                            | Thru | Right | Peds | Left           | Thru | Right | Peds |            |
| 06:00      | 19                              | 11   | 0     | 0    | 2              | 17   | 2     | 0    | 2                               | 3    | 13    | 0    | 4              | 58   | 4     | 0    | 135        |
| 06:15      | 24                              | 15   | 1     | 0    | 4              | 34   | 3     | 0    | 2                               | 2    | 21    | 0    | 2              | 63   | 0     | 0    | 171        |
| 06:30      | 27                              | 20   | 3     | 0    | 3              | 46   | 8     | 0    | 3                               | 10   | 17    | 0    | 7              | 72   | 4     | 0    | 220        |
| 06:45      | 31                              | 15   | 8     | 0    | 4              | 63   | 7     | 0    | 2                               | 10   | 28    | 0    | 3              | 75   | 4     | 0    | 250        |
| Total      | 101                             | 61   | 12    | 0    | 13             | 160  | 20    | 0    | 9                               | 25   | 79    | 0    | 16             | 268  | 12    | 0    | 776        |
| 07:00      | 36                              | 13   | 5     | 0    | 8              | 54   | 19    | 0    | 4                               | 16   | 30    | 0    | 9              | 107  | 4     | 0    | 305        |
| 07:15      | 39                              | 15   | 2     | 0    | 6              | 93   | 23    | 0    | 6                               | 18   | 40    | 0    | 9              | 91   | 0     | 0    | 342        |
| 07:30      | 39                              | 24   | 4     | 0    | 5              | 107  | 33    | 0    | 11                              | 25   | 35    | 0    | 4              | 107  | 7     | 0    | 401        |
| 07:45      | 50                              | 33   | 5     | 0    | 9              | 98   | 42    | 0    | 13                              | 20   | 28    | 0    | 9              | 107  | 15    | 0    | 429        |
| Total      | 164                             | 85   | 16    | 0    | 28             | 352  | 117   | 0    | 34                              | 79   | 133   | 0    | 31             | 412  | 26    | 0    | 1477       |
| 08:00      | 48                              | 27   | 3     | 0    | 6              | 67   | 16    | 0    | 10                              | 13   | 14    | 0    | 8              | 96   | 20    | 0    | 328        |
| 08:15      | 27                              | 26   | 7     | 0    | 6              | 57   | 10    | 0    | 11                              | 10   | 14    | 0    | 10             | 71   | 12    | 0    | 261        |
| 08:30      | 25                              | 14   | 6     | 0    | 13             | 63   | 19    | 0    | 9                               | 7    | 21    | 0    | 2              | 81   | 11    | 0    | 271        |
| 08:45      | 26                              | 16   | 2     | 0    | 10             | 73   | 14    | 0    | 8                               | 12   | 12    | 0    | 4              | 69   | 10    | 0    | 256        |
| Total      | 126                             | 83   | 18    | 0    | 35             | 260  | 59    | 0    | 38                              | 42   | 61    | 0    | 24             | 317  | 53    | 0    | 1116       |
| 09:00      | 19                              | 15   | 6     | 0    | 14             | 70   | 11    | 0    | 11                              | 11   | 15    | 0    | 12             | 53   | 10    | 0    | 247        |
| 09:15      | 15                              | 14   | 10    | 0    | 6              | 57   | 13    | 0    | 6                               | 12   | 18    | 0    | 5              | 71   | 13    | 0    | 240        |
| 09:30      | 17                              | 13   | 4     | 0    | 8              | 40   | 12    | 0    | 8                               | 9    | 11    | 0    | 6              | 56   | 7     | 0    | 191        |
| 09:45      | 20                              | 13   | 4     | 0    | 8              | 45   | 14    | 0    | 9                               | 12   | 18    | 0    | 7              | 50   | 11    | 0    | 211        |
| Total      | 71                              | 55   | 24    | 0    | 36             | 212  | 50    | 0    | 34                              | 44   | 62    | 0    | 30             | 230  | 41    | 0    | 889        |
| 10:00      | 16                              | 15   | 8     | 0    | 12             | 56   | 8     | 0    | 11                              | 12   | 13    | 0    | 10             | 45   | 17    | 0    | 223        |
| 10:15      | 15                              | 11   | 6     | 0    | 8              | 55   | 17    | 0    | 10                              | 14   | 17    | 0    | 8              | 62   | 20    | 0    | 243        |
| 10:30      | 17                              | 9    | 11    | 0    | 7              | 59   | 23    | 0    | 16                              | 18   | 15    | 0    | 5              | 46   | 10    | 0    | 236        |
| 10:45      | 19                              | 13   | 3     | 0    | 8              | 52   | 24    | 0    | 17                              | 17   | 11    | 0    | 9              | 53   | 21    | 0    | 247        |
| Total      | 67                              | 48   | 28    | 0    | 35             | 222  | 72    | 0    | 54                              | 61   | 56    | 0    | 32             | 206  | 68    | 0    | 949        |
| 11:00      | 13                              | 19   | 15    | 0    | 8              | 53   | 16    | 1    | 15                              | 13   | 8     | 0    | 7              | 57   | 19    | 0    | 244        |
| 11:15      | 15                              | 21   | 9     | 0    | 6              | 49   | 21    | 0    | 8                               | 15   | 18    | 0    | 12             | 47   | 14    | 0    | 235        |
| 11:30      | 20                              | 16   | 5     | 0    | 8              | 59   | 12    | 0    | 13                              | 9    | 9     | 0    | 4              | 56   | 23    | 0    | 234        |
| 11:45      | 23                              | 24   | 8     | 0    | 14             | 66   | 13    | 0    | 17                              | 17   | 5     | 0    | 7              | 64   | 18    | 0    | 276        |
| Total      | 71                              | 80   | 37    | 0    | 36             | 227  | 62    | 1    | 53                              | 54   | 40    | 0    | 30             | 224  | 74    | 0    | 989        |
| 12:00      | 21                              | 16   | 5     | 0    | 12             | 56   | 22    | 2    | 12                              | 16   | 11    | 0    | 12             | 72   | 28    | 0    | 285        |
| 12:15      | 27                              | 12   | 11    | 0    | 17             | 61   | 5     | 0    | 18                              | 13   | 16    | 0    | 11             | 66   | 20    | 0    | 277        |
| 12:30      | 16                              | 20   | 10    | 0    | 6              | 61   | 11    | 1    | 14                              | 22   | 15    | 0    | 9              | 68   | 24    | 1    | 278        |
| 12:45      | 16                              | 11   | 12    | 0    | 11             | 73   | 15    | 1    | 16                              | 15   | 15    | 0    | 7              | 57   | 15    | 0    | 264        |
| Total      | 80                              | 59   | 38    | 0    | 46             | 251  | 53    | 4    | 60                              | 66   | 57    | 0    | 39             | 263  | 87    | 1    | 1104       |
| 13:00      | 15                              | 15   | 8     | 0    | 10             | 57   | 15    | 0    | 14                              | 18   | 12    | 0    | 12             | 53   | 18    | 0    | 247        |
| 13:15      | 18                              | 21   | 10    | 0    | 11             | 63   | 11    | 0    | 17                              | 21   | 16    | 0    | 10             | 64   | 13    | 0    | 275        |
| 13:30      | 14                              | 21   | 9     | 0    | 14             | 62   | 20    | 2    | 16                              | 21   | 12    | 0    | 10             | 77   | 14    | 1    | 293        |
| 13:45      | 14                              | 18   | 11    | 0    | 9              | 63   | 20    | 1    | 19                              | 16   | 12    | 0    | 10             | 53   | 13    | 0    | 259        |
| Total      | 61                              | 75   | 38    | 0    | 44             | 245  | 66    | 3    | 66                              | 76   | 52    | 0    | 42             | 247  | 58    | 1    | 1074       |
| 14:00      | 20                              | 17   | 9     | 0    | 9              | 69   | 23    | 0    | 16                              | 17   | 7     | 0    | 11             | 62   | 10    | 0    | 270        |
| 14:15      | 19                              | 16   | 15    | 0    | 23             | 94   | 25    | 1    | 25                              | 35   | 12    | 0    | 8              | 79   | 21    | 0    | 373        |
| 14:30      | 16                              | 23   | 10    | 0    | 8              | 79   | 36    | 1    | 25                              | 24   | 14    | 0    | 6              | 75   | 17    | 0    | 334        |
| 14:45      | 29                              | 18   | 16    | 0    | 13             | 93   | 23    | 0    | 24                              | 35   | 17    | 0    | 9              | 71   | 20    | 0    | 368        |
| Total      | 84                              | 74   | 50    | 0    | 53             | 335  | 107   | 2    | 90                              | 111  | 50    | 0    | 34             | 287  | 68    | 0    | 1345       |
| 15:00      | 34                              | 21   | 9     | 0    | 22             | 70   | 26    | 0    | 17                              | 14   | 18    | 0    | 14             | 109  | 20    | 0    | 374        |
| 15:15      | 18                              | 23   | 13    | 0    | 14             | 104  | 18    | 0    | 11                              | 9    | 10    | 0    | 7              | 60   | 29    | 0    | 316        |
| 15:30      | 28                              | 18   | 19    | 0    | 17             | 98   | 36    | 0    | 19                              | 29   | 11    | 0    | 10             | 76   | 22    | 0    | 383        |

# TRAFFIC DATA INC.

3268 Xenwood Ave S  
St Louis Park, MN 55416

TH-5 at CSAH-59 / Main St E WACONIA  
Ref.Pt.: 033.022  
TDI Inc  
TURN MOVEMENT COUNT

File Name : 2681116 Hwy 5 & CR 59  
Site Code : 2681116  
Start Date : 2/16/2011  
Page No : 2

Groups Printed- Class 1

| Start Time  | Co.Rd.59 / Main St E Southbound |      |      |      | TH-5 Westbound |      |      |      | Co.Rd.59 / Main St E Northbound |      |      |      | TH-5 Eastbound |      |      |      | Int. Total |
|-------------|---------------------------------|------|------|------|----------------|------|------|------|---------------------------------|------|------|------|----------------|------|------|------|------------|
|             | Left                            | Thru | Rght | Peds | Left           | Thru | Rght | Peds | Left                            | Thru | Rght | Peds | Left           | Thru | Rght | Peds |            |
| 15:45       | 31                              | 20   | 11   | 0    | 24             | 121  | 45   | 0    | 21                              | 23   | 20   | 0    | 7              | 96   | 23   | 0    | 442        |
| Total       | 111                             | 82   | 52   | 0    | 77             | 393  | 125  | 0    | 68                              | 75   | 59   | 0    | 38             | 341  | 94   | 0    | 1515       |
| 16:00       | 26                              | 22   | 12   | 0    | 17             | 109  | 31   | 0    | 26                              | 23   | 14   | 0    | 7              | 79   | 18   | 0    | 384        |
| 16:15       | 22                              | 23   | 10   | 0    | 28             | 97   | 29   | 0    | 21                              | 29   | 14   | 0    | 8              | 91   | 14   | 0    | 386        |
| 16:30       | 27                              | 37   | 8    | 0    | 28             | 130  | 44   | 0    | 33                              | 40   | 13   | 2    | 10             | 94   | 27   | 0    | 493        |
| 16:45       | 39                              | 29   | 13   | 0    | 19             | 116  | 35   | 0    | 29                              | 39   | 19   | 1    | 9              | 78   | 20   | 0    | 446        |
| Total       | 114                             | 111  | 43   | 0    | 92             | 452  | 139  | 0    | 109                             | 131  | 60   | 3    | 34             | 342  | 79   | 0    | 1709       |
| 17:00       | 35                              | 24   | 15   | 0    | 31             | 119  | 46   | 0    | 25                              | 40   | 27   | 0    | 11             | 89   | 19   | 0    | 481        |
| 17:15       | 23                              | 26   | 17   | 0    | 36             | 107  | 44   | 0    | 26                              | 30   | 20   | 0    | 11             | 70   | 19   | 0    | 429        |
| 17:30       | 25                              | 19   | 13   | 0    | 34             | 113  | 42   | 0    | 21                              | 36   | 13   | 0    | 4              | 80   | 15   | 0    | 415        |
| 17:45       | 25                              | 20   | 13   | 0    | 31             | 111  | 43   | 0    | 28                              | 41   | 20   | 0    | 8              | 64   | 19   | 0    | 423        |
| Total       | 108                             | 89   | 58   | 0    | 132            | 450  | 175  | 0    | 100                             | 147  | 80   | 0    | 34             | 303  | 72   | 0    | 1748       |
| 18:00       | 34                              | 22   | 7    | 0    | 22             | 88   | 34   | 0    | 14                              | 30   | 18   | 0    | 5              | 81   | 15   | 0    | 370        |
| 18:15       | 27                              | 20   | 6    | 0    | 29             | 95   | 43   | 0    | 16                              | 34   | 13   | 0    | 8              | 65   | 15   | 0    | 371        |
| 18:30       | 21                              | 28   | 10   | 0    | 23             | 65   | 24   | 0    | 19                              | 22   | 11   | 0    | 4              | 63   | 13   | 0    | 303        |
| 18:45       | 12                              | 18   | 4    | 0    | 22             | 72   | 22   | 0    | 17                              | 13   | 11   | 0    | 3              | 48   | 12   | 0    | 254        |
| Total       | 94                              | 88   | 27   | 0    | 96             | 320  | 123  | 0    | 66                              | 99   | 53   | 0    | 20             | 257  | 55   | 0    | 1298       |
| Grand Total | 1252                            | 990  | 441  | 0    | 723            | 3879 | 1168 | 10   | 781                             | 1010 | 842  | 3    | 404            | 3697 | 787  | 2    | 15989      |
| Apprch %    | 46.7                            | 36.9 | 16.4 | 0    | 12.5           | 67.1 | 20.2 | 0.2  | 29.6                            | 38.3 | 31.9 | 0.1  | 8.3            | 75.6 | 16.1 | 0    |            |
| Total %     | 7.8                             | 6.2  | 2.8  | 0    | 4.5            | 24.3 | 7.3  | 0.1  | 4.9                             | 6.3  | 5.3  | 0    | 2.5            | 23.1 | 4.9  | 0    |            |

# TRAFFIC DATA INC.

3268 Xenwood Ave S  
St Louis Park, MN 55416

TH-5 at CSAH-59 / Main St E WACONIA  
Ref.Pt.: 033.022  
TDI Inc  
TURN MOVEMENT COUNT

File Name : 2681116 Hwy 5 & CR 59  
Site Code : 2681116  
Start Date : 2/16/2011  
Page No : 3

| Start Time   | Co.Rd.59 / Main St E Southbound |      |      |      |            | TH-5 Westbound |      |      |      |            | Co.Rd.59 / Main St E Northbound |      |      |      |            | TH-5 Eastbound |      |      |      |            | Int. Total |
|--|---------------------------------|------|------|------|------------|----------------|------|------|------|------------|---------------------------------|------|------|------|------------|----------------|------|------|------|------------|------------|
|  | Left                            | Thru | Rght | Peds | App. Total | Left           | Thru | Rght | Peds | App. Total | Left                            | Thru | Rght | Peds | App. Total | Left           | Thru | Rght | Peds | App. Total |            |
| Peak Hour Analysis From 06:00 to 09:30 - Peak 1 of 1 |                                 |      |      |      |            |                |      |      |      |            |                                 |      |      |      |            |                |      |      |      |            |            |
| Peak Hour for Entire Intersection Begins at 07:15    |                                 |      |      |      |            |                |      |      |      |            |                                 |      |      |      |            |                |      |      |      |            |            |
| 07:15  | 39                              | 15   | 2    | 0    | 56         | 6              | 93   | 23   | 0    | 122        | 6                               | 18   | 40   | 0    | 64         | 9              | 91   | 0    | 0    | 100        | 342        |
| 07:30  | 39                              | 24   | 4    | 0    | 67         | 5              | 107  | 33   | 0    | 145        | 11                              | 25   | 35   | 0    | 71         | 4              | 107  | 7    | 0    | 118        | 401        |
| 07:45  | 50                              | 33   | 5    | 0    | 88         | 9              | 98   | 42   | 0    | 149        | 13                              | 20   | 28   | 0    | 61         | 9              | 107  | 15   | 0    | 131        | 429        |
| 08:00  | 48                              | 27   | 3    | 0    | 78         | 6              | 67   | 16   | 0    | 89         | 10                              | 13   | 14   | 0    | 37         | 8              | 96   | 20   | 0    | 124        | 328        |
| Total Volume   | 176                             | 99   | 14   | 0    | 289        | 26             | 365  | 114  | 0    | 505        | 40                              | 76   | 117  | 0    | 233        | 30             | 401  | 42   | 0    | 473        | 1500       |
| % App. Total   | 60.9                            | 34.3 | 4.8  | 0    |            | 5.1            | 72.3 | 22.6 | 0    |            | 17.2                            | 32.6 | 50.2 | 0    |            | 6.3            | 84.8 | 8.9  | 0    |            |            |
| PHF  | .880                            | .750 | .700 | .000 | .821       | .722           | .853 | .679 | .000 | .847       | .769                            | .760 | .731 | .000 | .820       | .833           | .937 | .525 | .000 | .903       | .874       |

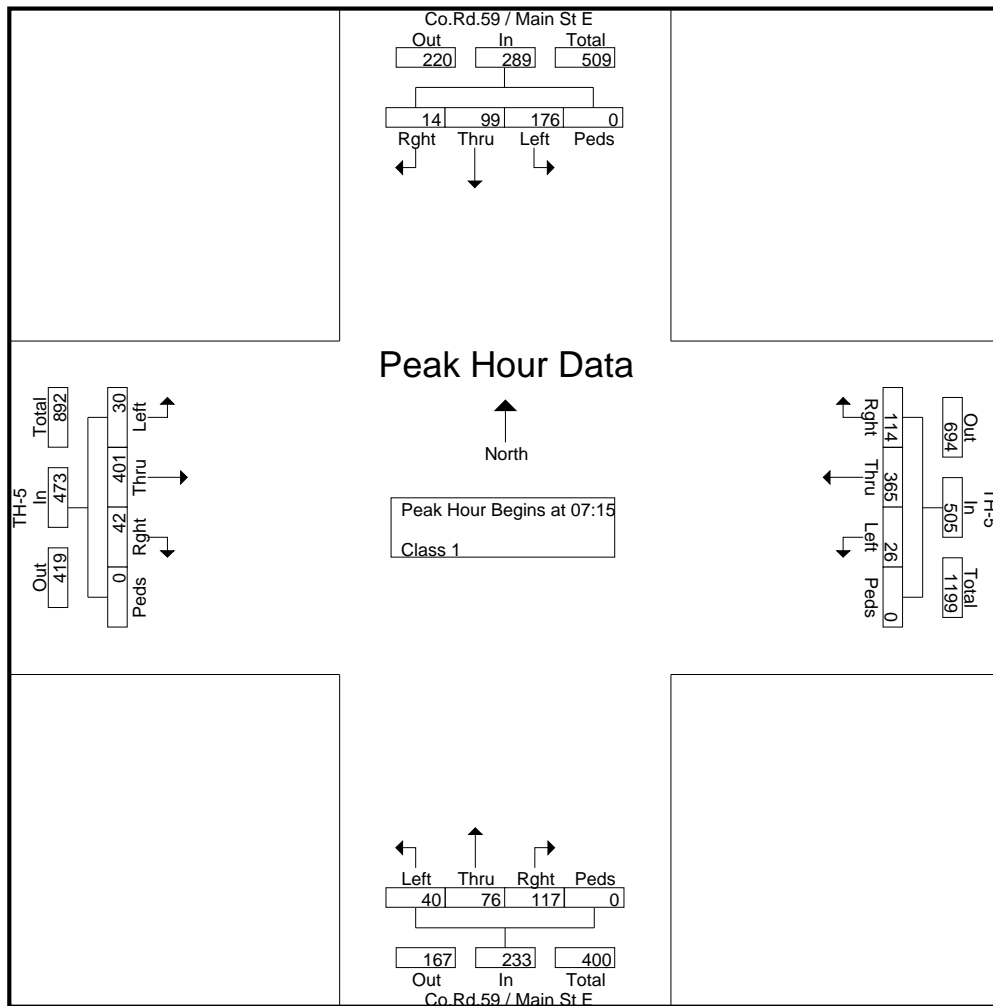

# TRAFFIC DATA INC.

3268 Xenwood Ave S  
St Louis Park, MN 55416

TH-5 at CSAH-59 / Main St E WACONIA  
Ref.Pt.: 033.022  
TDI Inc  
TURN MOVEMENT COUNT

File Name : 2681116 Hwy 5 & CR 59  
Site Code : 2681116  
Start Date : 2/16/2011  
Page No : 4

| Start Time   | Co.Rd.59 / Main St E Southbound |      |      |      |            | TH-5 Westbound |      |      |      |            | Co.Rd.59 / Main St E Northbound |      |      |      |            | TH-5 Eastbound |      |      |      |            | Int. Total |
|--|---------------------------------|------|------|------|------------|----------------|------|------|------|------------|---------------------------------|------|------|------|------------|----------------|------|------|------|------------|------------|
|  | Left                            | Thru | Rght | Peds | App. Total | Left           | Thru | Rght | Peds | App. Total | Left                            | Thru | Rght | Peds | App. Total | Left           | Thru | Rght | Peds | App. Total |            |
| Peak Hour Analysis From 14:30 to 18:45 - Peak 1 of 1 |                                 |      |      |      |            |                |      |      |      |            |                                 |      |      |      |            |                |      |      |      |            |            |
| Peak Hour for Entire Intersection Begins at 16:30    |                                 |      |      |      |            |                |      |      |      |            |                                 |      |      |      |            |                |      |      |      |            |            |
| 16:30  | 27                              | 37   | 8    | 0    | 72         | 28             | 130  | 44   | 0    | 202        | 33                              | 40   | 13   | 2    | 88         | 10             | 94   | 27   | 0    | 131        | 493        |
| 16:45  | 39                              | 29   | 13   | 0    | 81         | 19             | 116  | 35   | 0    | 170        | 29                              | 39   | 19   | 1    | 88         | 9              | 78   | 20   | 0    | 107        | 446        |
| 17:00  | 35                              | 24   | 15   | 0    | 74         | 31             | 119  | 46   | 0    | 196        | 25                              | 40   | 27   | 0    | 92         | 11             | 89   | 19   | 0    | 119        | 481        |
| 17:15  | 23                              | 26   | 17   | 0    | 66         | 36             | 107  | 44   | 0    | 187        | 26                              | 30   | 20   | 0    | 76         | 11             | 70   | 19   | 0    | 100        | 429        |
| Total Volume   | 124                             | 116  | 53   | 0    | 293        | 114            | 472  | 169  | 0    | 755        | 113                             | 149  | 79   | 3    | 344        | 41             | 331  | 85   | 0    | 457        | 1849       |
| % App. Total   | 42.3                            | 39.6 | 18.1 | 0    |            | 15.1           | 62.5 | 22.4 | 0    |            | 32.8                            | 43.3 | 23   | 0.9  |            | 9              | 72.4 | 18.6 | 0    |            |            |
| PHF  | .795                            | .784 | .779 | .000 | .904       | .792           | .908 | .918 | .000 | .934       | .856                            | .931 | .731 | .375 | .935       | .932           | .880 | .787 | .000 | .872       | .938       |

