



MINNESOTA DEPT OF TRANSPORTATION

TRAFFIC DATA COLLECTION - METRO

TH-5 at TH-36, north ramps STILLWATER
 Ref.Pt.: 201.318
 JAMAR # 631 RE
 TURN MOVEMENT COUNT

File Name : TH-5 at TH-36 north ramps 2010
 Site Code : 00000000
 Start Date : 12/2/2010
 Page No : 1

Groups Printed- Cars & Trucks

Start Time	TH-5 Southbound				ramp from WB TH-36 Westbound				TH-5 Northbound				ramp to WB TH-36 Eastbound				Int. Total	
	Left	Thru	Right	Peds	Left	Thru	Right	Peds	Left	Thru	Right	Peds	Left	Thru	Right	Peds		
06:00	0	43	38	0	9	0	0	0	11	22	0	0	0	0	0	0	0	123
06:15	0	53	58	0	17	0	1	0	15	24	0	0	0	0	0	0	0	168
06:30	0	78	80	0	18	0	6	0	21	39	0	0	0	0	0	0	0	242
06:45	0	76	78	0	20	0	6	0	21	38	0	0	0	0	0	0	0	239
Total	0	250	254	0	64	0	13	0	68	123	0	0	0	0	0	0	0	772
07:00	0	79	84	3	24	1	1	0	33	62	0	0	0	0	0	0	0	287
07:15	0	109	88	1	25	0	2	0	39	75	0	0	0	0	0	0	0	339
07:30	0	113	75	2	32	1	10	0	47	88	0	0	0	0	0	0	0	368
07:45	0	94	79	0	31	0	7	0	33	97	0	0	0	0	0	0	0	341
Total	0	395	326	6	112	2	20	0	152	322	0	0	0	0	0	0	0	1335
08:00	0	71	65	2	24	0	7	0	32	89	0	0	0	0	0	0	0	290
08:15	0	93	55	0	40	2	8	0	41	88	0	0	0	0	0	0	0	327
08:30	0	91	59	0	35	2	8	0	34	106	0	0	0	0	0	0	0	335
08:45	0	92	51	0	28	0	12	0	48	126	0	0	0	0	0	0	0	357
Total	0	347	230	2	127	4	35	0	155	409	0	0	0	0	0	0	0	1309
*** BREAK ***																		
15:00	0	90	83	0	53	0	17	0	54	166	0	1	0	0	0	0	0	464
15:15	0	102	61	0	51	0	21	0	65	214	0	0	0	0	0	0	0	514
15:30	0	106	60	0	46	1	22	0	53	221	0	1	0	0	0	0	0	510
15:45	0	94	66	0	44	0	20	0	59	204	0	2	0	0	0	0	0	489
Total	0	392	270	0	194	1	80	0	231	805	0	4	0	0	0	0	0	1977
16:00	0	101	79	0	46	0	18	0	46	210	0	1	0	0	0	0	0	501
16:15	0	114	64	0	41	0	12	0	54	205	0	0	0	0	0	0	0	490
16:30	0	119	79	0	40	2	13	0	61	211	0	0	0	0	0	0	0	525
16:45	0	127	60	5	43	9	6	0	55	201	0	0	0	0	0	0	0	506
Total	0	461	282	5	170	11	49	0	216	827	0	1	0	0	0	0	0	2022
17:00	0	123	86	0	60	0	23	0	70	229	0	0	0	0	0	0	0	591
17:15	0	116	75	0	49	0	22	0	49	240	0	0	0	0	0	0	0	551
17:30	0	109	78	0	27	0	13	0	49	233	0	0	0	0	0	0	0	509
17:45	0	91	71	0	33	0	17	0	50	224	0	0	0	0	0	0	0	486
Total	0	439	310	0	169	0	75	0	218	926	0	0	0	0	0	0	0	2137
Grand Total	0	2284	1672	13	836	18	272	0	1040	3412	0	5	0	0	0	0	0	9552
Apprch %	0	57.5	42.1	0.3	74.2	1.6	24.2	0	23.3	76.6	0	0.1	0	0	0	0	0	
Total %	0	23.9	17.5	0.1	8.8	0.2	2.8	0	10.9	35.7	0	0.1	0	0	0	0	0	



MINNESOTA DEPT OF TRANSPORTATION

TRAFFIC DATA COLLECTION - METRO

TH-5 at TH-36, north ramps STILLWATER
 Ref.Pt.: 201.318
 JAMAR # 631 RE
 TURN MOVEMENT COUNT

File Name : TH-5 at TH-36 north ramps 2010
 Site Code : 00000000
 Start Date : 12/2/2010
 Page No : 2

Start Time	TH-5 Southbound					ramp from WB TH-36 Westbound					TH-5 Northbound					ramp to WB TH-36 Eastbound					Int. Total
	Left	Thru	Right	Peds	App. Total	Left	Thru	Right	Peds	App. Total	Left	Thru	Right	Peds	App. Total	Left	Thru	Right	Peds	App. Total	
Peak Hour Analysis From 06:00 to 08:45 - Peak 1 of 1																					
Peak Hour for Entire Intersection Begins at 07:15																					
07:15	0	109	88	1	198	25	0	2	0	27	39	75	0	0	114	0	0	0	0	0	339
07:30	0	113	75	2	190	32	1	10	0	43	47	88	0	0	135	0	0	0	0	0	368
07:45	0	94	79	0	173	31	0	7	0	38	33	97	0	0	130	0	0	0	0	0	341
08:00	0	71	65	2	138	24	0	7	0	31	32	89	0	0	121	0	0	0	0	0	290
Total Volume	0	387	307	5	699	112	1	26	0	139	151	349	0	0	500	0	0	0	0	0	1338
% App. Total	0	55.4	43.9	0.7		80.6	0.7	18.7	0		30.2	69.8	0	0		0	0	0	0		
PHF	.000	.856	.872	.625	.883	.875	.250	.650	.000	.808	.803	.899	.000	.000	.926	.000	.000	.000	.000	.000	.909

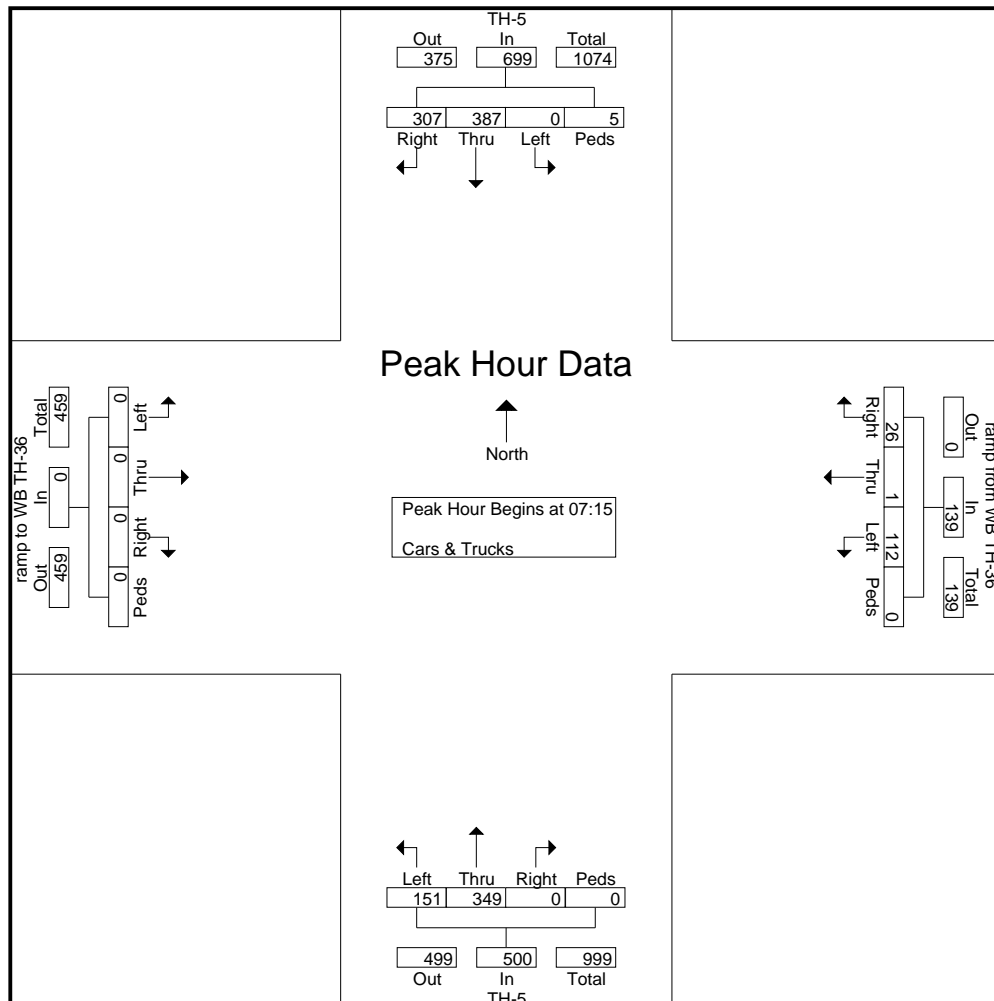



MINNESOTA DEPT OF TRANSPORTATION

TRAFFIC DATA COLLECTION - METRO

TH-5 at TH-36, north ramps STILLWATER
 Ref.Pt.: 201.318
 JAMAR # 631 RE
 TURN MOVEMENT COUNT

File Name : TH-5 at TH-36 north ramps 2010
 Site Code : 00000000
 Start Date : 12/2/2010
 Page No : 3

Start Time	TH-5 Southbound					ramp from WB TH-36 Westbound					TH-5 Northbound					ramp to WB TH-36 Eastbound					Int. Total
	Left	Thru	Right	Peds	App. Total	Left	Thru	Right	Peds	App. Total	Left	Thru	Right	Peds	App. Total	Left	Thru	Right	Peds	App. Total	

Peak Hour Analysis From 15:00 to 17:45 - Peak 1 of 1
 Peak Hour for Entire Intersection Begins at 16:30

16:30	0	119	79	0	198	40	2	13	0	55	61	211	0	0	272	0	0	0	0	0	525
16:45	0	127	60	5	192	43	9	6	0	58	55	201	0	0	256	0	0	0	0	0	506
17:00	0	123	86	0	209	60	0	23	0	83	70	229	0	0	299	0	0	0	0	0	591
17:15	0	116	75	0	191	49	0	22	0	71	49	240	0	0	289	0	0	0	0	0	551
Total Volume	0	485	300	5	790	192	11	64	0	267	235	881	0	0	1116	0	0	0	0	0	2173
% App. Total	0	61.4	38	0.6		71.9	4.1	24	0		21.1	78.9	0	0		0	0	0	0		
PHF	.000	.955	.872	.250	.945	.800	.306	.696	.000	.804	.839	.918	.000	.000	.933	.000	.000	.000	.000	.000	.919

