

Associated Consulting Services (ACS)
Roseville, MN 55113
-- TRAFFIC DATA --

MN-51 at Sargent Ave_2021
Data Prepared By: ACS
TURNING MOVEMENT COUNT

File Name : MN-51 at Sargent Ave_2021
Site Code :
Start Date : 10/19/2021
Page No : 1

Groups Printed- Cars - Trucks

Start Time	MN-51 Southbound				Sargent Ave Westbound				MN-51 Northbound				Eastbound				Int. Total	
	Left	Thru	Right	Peds	Left	Thru	Right	Peds	Left	Thru	Right	Peds	Left	Thru	Right	Peds		
06:00	0	30	0	0	0	0	1	0	0	45	0	0	0	0	0	0	0	76
06:15	0	46	0	0	0	0	1	0	0	57	0	0	0	0	0	0	0	104
06:30	0	59	0	1	0	0	2	0	0	70	0	0	0	0	0	0	0	132
06:45	0	73	0	0	0	0	0	2	0	84	0	0	0	0	0	0	0	159
Total	0	208	0	1	0	0	4	2	0	256	0	0	0	0	0	0	0	471
07:00	0	91	0	1	0	0	1	1	0	92	0	0	0	0	0	0	0	186
07:15	0	106	0	1	0	0	0	1	0	103	2	0	0	0	0	0	0	213
07:30	0	145	0	0	0	0	2	2	0	129	0	0	0	0	0	0	0	278
07:45	0	159	0	2	0	0	2	7	0	141	0	0	0	0	0	0	0	311
Total	0	501	0	4	0	0	5	11	0	465	2	0	0	0	0	0	0	988
08:00	0	152	0	0	0	0	0	4	0	177	0	0	0	0	0	0	0	333
08:15	0	177	0	0	0	0	3	2	0	164	0	0	0	0	0	0	0	346
08:30	0	145	0	1	0	0	1	2	0	125	1	0	0	0	0	0	0	275
08:45	0	134	0	0	0	0	0	3	0	129	0	0	0	0	0	0	0	266
Total	0	608	0	1	0	0	4	11	0	595	1	0	0	0	0	0	0	1220
09:00	0	111	0	2	0	0	1	5	0	108	4	0	0	0	0	0	0	231
09:15	0	124	0	1	0	0	3	0	0	139	2	0	0	0	0	0	0	269
09:30	0	92	0	3	0	0	2	8	0	126	3	0	0	0	0	0	0	234
09:45	0	131	0	1	0	0	0	2	0	100	2	0	0	0	0	0	0	236
Total	0	458	0	7	0	0	6	15	0	473	11	0	0	0	0	0	0	970
10:00	0	123	0	2	0	0	1	3	0	111	1	0	0	0	0	0	0	241
10:15	0	118	0	0	0	0	0	4	0	107	1	0	0	0	0	0	0	230
10:30	0	93	0	0	0	0	2	4	0	155	1	0	0	0	0	0	0	255
10:45	0	114	0	3	0	0	2	7	0	127	1	0	0	0	0	0	0	254
Total	0	448	0	5	0	0	5	18	0	500	4	0	0	0	0	0	0	980
11:00	0	122	0	2	0	0	0	4	0	100	6	0	0	0	0	0	0	234
11:15	0	150	0	0	0	0	1	3	0	122	0	0	0	0	0	0	0	276
11:30	0	128	0	0	0	0	2	4	0	155	8	0	0	0	0	0	0	297
11:45	0	154	0	1	0	0	0	5	0	133	3	0	0	0	0	0	0	296
Total	0	554	0	3	0	0	3	16	0	510	17	0	0	0	0	0	0	1103
12:00	0	113	0	2	0	0	3	3	0	128	3	0	0	0	0	0	0	252
12:15	0	138	0	0	0	0	0	3	0	119	1	0	0	0	0	0	0	261
12:30	0	144	0	4	0	0	1	10	0	118	3	0	0	0	0	0	0	280
12:45	0	144	0	2	0	0	0	3	0	118	1	0	0	0	0	0	0	268
Total	0	539	0	8	0	0	4	19	0	483	8	0	0	0	0	0	0	1061
13:00	0	124	0	4	0	0	1	6	0	121	3	0	0	0	0	0	0	259
13:15	0	135	0	2	0	0	2	4	0	116	1	0	0	0	0	0	0	260
13:30	0	147	0	1	0	0	0	6	0	109	2	0	0	0	0	0	0	265
13:45	0	149	0	2	0	0	1	6	0	131	3	0	0	0	0	0	0	292
Total	0	555	0	9	0	0	4	22	0	477	9	0	0	0	0	0	0	1076
14:00	0	111	0	1	0	0	1	5	0	131	3	0	0	0	0	0	0	252
14:15	0	174	0	1	0	0	3	5	0	122	5	0	0	0	0	0	0	310
14:30	0	150	0	1	0	0	2	4	0	121	2	0	0	0	0	0	0	280
14:45	0	201	0	2	0	0	3	8	0	135	1	0	0	0	0	0	0	350
Total	0	636	0	5	0	0	9	22	0	509	11	0	0	0	0	0	0	1192

Associated Consulting Services (ACS)
 Roseville, MN 55113
 -- TRAFFIC DATA --

MN-51 at Sargent Ave_2021
 Data Prepared By: ACS
 TURNING MOVEMENT COUNT

File Name : MN-51 at Sargent Ave_2021
 Site Code :
 Start Date : 10/19/2021
 Page No : 2

Groups Printed- Cars - Trucks

Start Time	MN-51 Southbound				Sargent Ave Westbound				MN-51 Northbound				Eastbound				Int. Total
	Left	Thru	Right	Peds	Left	Thru	Right	Peds	Left	Thru	Right	Peds	Left	Thru	Right	Peds	
15:00	0	215	0	2	0	0	2	7	0	157	4	0	0	0	0	0	387
15:15	0	185	0	0	0	0	4	4	0	158	2	0	0	0	0	0	353
15:30	0	199	0	0	0	0	0	1	0	150	1	0	0	0	0	0	351
15:45	0	183	0	0	0	0	2	7	0	171	3	0	0	0	0	0	366
Total	0	782	0	2	0	0	8	19	0	636	10	0	0	0	0	0	1457
16:00	0	157	0	0	0	0	2	5	0	167	3	0	0	0	0	0	334
16:15	0	186	0	2	0	0	5	9	0	123	5	0	0	0	0	0	330
16:30	0	202	0	4	0	0	2	12	0	148	2	0	0	0	0	0	370
16:45	0	186	0	3	0	0	2	5	0	156	0	0	0	0	0	0	352
Total	0	731	0	9	0	0	11	31	0	594	10	0	0	0	0	0	1386
17:00	0	163	0	0	0	0	1	4	0	150	2	0	0	0	0	0	320
17:15	0	194	0	3	0	0	1	8	0	159	4	0	0	0	0	0	369
17:30	0	182	0	1	0	0	1	8	0	150	6	0	0	0	0	0	348
17:45	0	186	0	3	0	0	0	9	0	163	5	0	0	0	0	0	366
Total	0	725	0	7	0	0	3	29	0	622	17	0	0	0	0	0	1403
Grand Total	0	6745	0	61	0	0	66	215	0	6120	100	0	0	0	0	0	13307
Apprch %	0	99.1	0	0.9	0	0	23.5	76.5	0	98.4	1.6	0	0	0	0	0	
Total %	0	50.7	0	0.5	0	0	0.5	1.6	0	46	0.8	0	0	0	0	0	
Cars	0	6237	0	61	0	0	63	215	0	5681	95	0	0	0	0	0	12352
% Cars	0	92.5	0	100	0	0	95.5	100	0	92.8	95	0	0	0	0	0	92.8
Trucks	0	508	0	0	0	0	3	0	0	439	5	0	0	0	0	0	955
% Trucks	0	7.5	0	0	0	0	4.5	0	0	7.2	5	0	0	0	0	0	7.2

Associated Consulting Services (ACS)
 Roseville, MN 55113
 -- TRAFFIC DATA --

MN-51 at Sargent Ave_2021
 Data Prepared By: ACS
 TURNING MOVEMENT COUNT

File Name : MN-51 at Sargent Ave_2021
 Site Code :
 Start Date : 10/19/2021
 Page No : 3

Start Time	MN-51 Southbound					Sargent Ave Westbound					MN-51 Northbound					Eastbound					Int. Total
	Left	Thru	Right	Peds	App. Total	Left	Thru	Right	Peds	App. Total	Left	Thru	Right	Peds	App. Total	Left	Thru	Right	Peds	App. Total	
Peak Hour Analysis From 06:00 to 11:45 - Peak 1 of 1																					
Peak Hour for Entire Intersection Begins at 07:30																					
07:30	0	145	0	0	145	0	0	2	2	4	0	129	0	0	129	0	0	0	0	0	278
07:45	0	159	0	2	161	0	0	2	7	9	0	141	0	0	141	0	0	0	0	0	311
08:00	0	152	0	0	152	0	0	0	4	4	0	177	0	0	177	0	0	0	0	0	333
08:15	0	177	0	0	177	0	0	3	2	5	0	164	0	0	164	0	0	0	0	0	346
Total Volume	0	633	0	2	635	0	0	7	15	22	0	611	0	0	611	0	0	0	0	0	1268
% App. Total	0	99.7	0	0.3		0	0	31.8	68.2		0	100	0	0		0	0	0	0		
PHF	.000	.894	.000	.250	.897	.000	.000	.583	.536	.611	.000	.863	.000	.000	.863	.000	.000	.000	.000	.000	.916

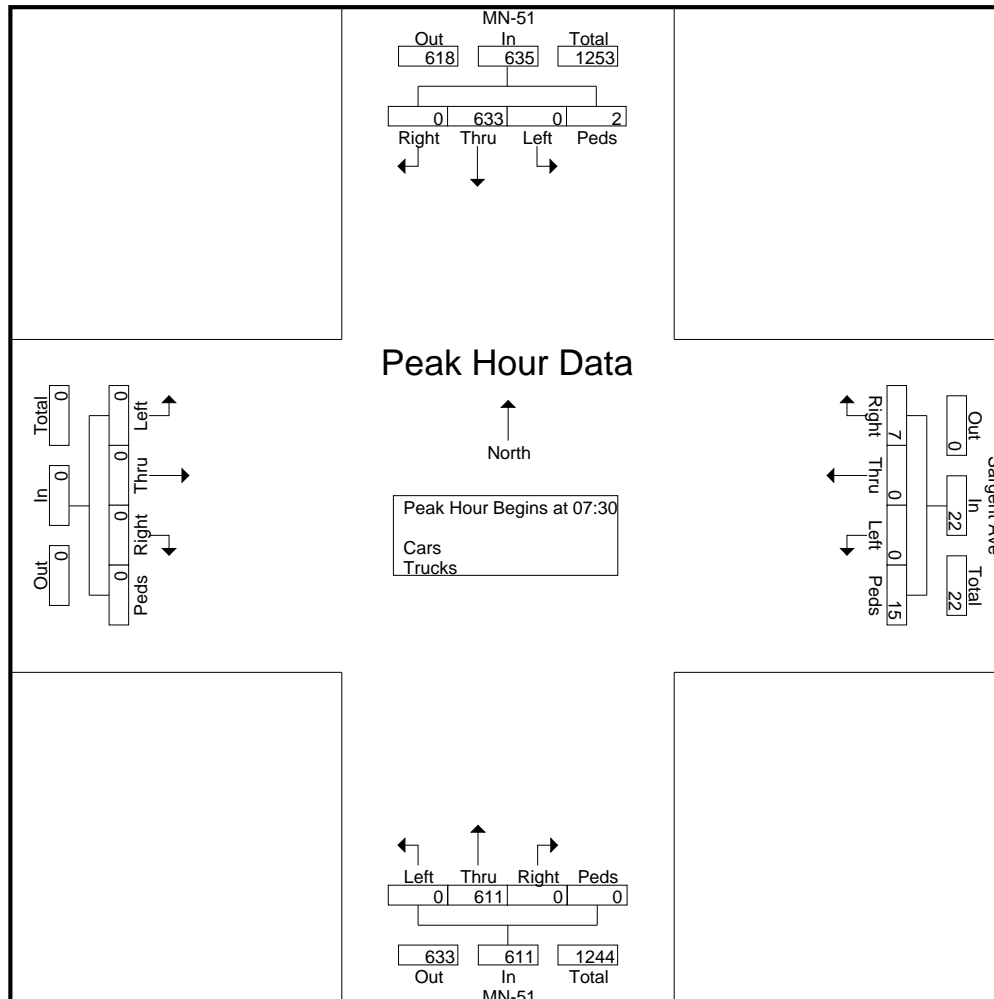

Associated Consulting Services (ACS)
 Roseville, MN 55113
 -- TRAFFIC DATA --

MN-51 at Sargent Ave_2021
 Data Prepared By: ACS
 TURNING MOVEMENT COUNT

File Name : MN-51 at Sargent Ave_2021
 Site Code :
 Start Date : 10/19/2021
 Page No : 4

Start Time	MN-51 Southbound					Sargent Ave Westbound					MN-51 Northbound					Eastbound					Int. Total
	Left	Thru	Right	Peds	App. Total	Left	Thru	Right	Peds	App. Total	Left	Thru	Right	Peds	App. Total	Left	Thru	Right	Peds	App. Total	
Peak Hour Analysis From 12:00 to 17:45 - Peak 1 of 1																					
Peak Hour for Entire Intersection Begins at 15:00																					
15:00	0	215	0	2	217	0	0	2	7	9	0	157	4	0	161	0	0	0	0	0	387
15:15	0	185	0	0	185	0	0	4	4	8	0	158	2	0	160	0	0	0	0	0	353
15:30	0	199	0	0	199	0	0	0	1	1	0	150	1	0	151	0	0	0	0	0	351
15:45	0	183	0	0	183	0	0	2	7	9	0	171	3	0	174	0	0	0	0	0	366
Total Volume	0	782	0	2	784	0	0	8	19	27	0	636	10	0	646	0	0	0	0	0	1457
% App. Total	0	99.7	0	0.3		0	0	29.6	70.4		0	98.5	1.5	0		0	0	0	0		
PHF	.000	.909	.000	.250	.903	.000	.000	.500	.679	.750	.000	.930	.625	.000	.928	.000	.000	.000	.000	.000	.941

