

SEH CONSULTING  
Traffic Data Collection  
TURN MOVEMENT COUNT

TH-51 / Snelling Ave at HarMar Mall entr  
Ref.Pt.: 007.155  
data by SEH  
TURN MOVEMENT COUNT

File Name : TH-51 at HarMar entrance 2008  
Site Code : 00000181  
Start Date : 11/19/2008  
Page No : 1

Groups Printed- Unshifted - Heavy Veh

Start Time	TH-51 / Snelling Ave. Southbound				HarMar entrance Westbound				TH-51 / Snelling Ave. Northbound				W Frontage Road connector Eastbound				Int. Total
	Left	Thru	Right	Peds	Left	Thru	Right	Peds	Left	Thru	Right	Peds	Left	Thru	Right	Peds	
06:00	3	81	5	1	1	0	2	0	1	69	2	0	3	0	6	0	174
06:15	1	131	7	2	2	0	0	0	4	90	5	0	2	0	9	0	253
06:30	7	198	19	0	1	0	4	0	8	110	3	0	8	2	19	0	379
06:45	15	284	11	0	5	2	1	0	7	145	8	0	6	0	9	0	493
Total	26	694	42	3	9	2	7	0	20	414	18	0	19	2	43	0	1299
07:00	4	279	11	0	2	2	12	0	4	145	4	0	6	0	9	0	478
07:15	5	365	25	1	6	5	4	0	14	188	5	0	9	2	29	0	658
07:30	3	376	22	10	4	5	6	1	8	239	6	0	12	4	21	1	718
07:45	3	397	27	0	6	0	6	0	20	261	8	0	12	2	28	0	770
Total	15	1417	85	11	18	12	28	1	46	833	23	0	39	8	87	1	2624
08:00	7	327	22	0	6	0	3	0	16	228	11	0	12	4	19	0	655
08:15	4	330	17	0	4	2	4	0	13	218	13	1	9	3	21	0	639
08:30	12	276	19	1	7	3	11	0	16	180	14	0	9	1	29	0	578
08:45	11	279	18	1	10	3	8	0	15	224	20	0	18	7	18	0	632
Total	34	1212	76	2	27	8	26	0	60	850	58	1	48	15	87	0	2504
*** BREAK ***																	
11:00	26	208	24	2	20	9	31	0	13	190	36	3	19	4	20	0	605
11:15	26	175	22	1	23	6	28	0	25	262	37	0	23	6	19	0	653
11:30	28	185	22	1	30	19	25	1	32	218	39	2	19	3	28	0	652
11:45	35	169	37	0	37	10	29	0	35	216	47	0	24	11	28	0	678
Total	115	737	105	4	110	44	113	1	105	886	159	5	85	24	95	0	2588
12:00	40	210	41	2	47	11	45	0	46	227	50	1	29	6	33	0	788
12:15	34	206	35	0	45	9	42	0	40	237	39	0	34	9	41	0	771
12:30	31	218	34	1	41	11	37	1	26	204	37	0	30	5	28	0	704
12:45	29	207	27	1	45	9	42	0	31	246	33	0	32	11	37	0	750
Total	134	841	137	4	178	40	166	1	143	914	159	1	125	31	139	0	3013
*** BREAK ***																	
15:00	27	220	19	1	28	12	47	0	10	287	29	1	19	7	12	1	720
15:15	18	241	13	3	32	8	36	0	11	300	28	0	11	7	18	0	726
15:30	16	231	21	5	34	5	26	0	13	321	28	0	15	5	11	0	731
15:45	21	223	13	0	27	3	30	1	15	322	84	5	29	8	12	0	793
Total	82	915	66	9	121	28	139	1	49	1230	169	6	74	27	53	1	2970
16:00	25	285	25	5	34	6	49	0	12	416	47	0	8	7	22	0	941
16:15	30	246	24	0	30	11	26	2	19	365	100	2	17	5	19	0	896
16:30	25	274	15	0	28	15	37	0	18	433	50	1	15	4	23	0	938
16:45	27	261	21	3	34	6	42	1	25	455	46	1	18	12	21	0	973
Total	107	1066	85	8	126	38	154	3	74	1669	243	4	58	28	85	0	3748
17:00	29	304	17	1	37	8	44	1	22	374	42	2	19	5	23	0	928
17:15	25	337	25	0	34	10	29	0	23	454	45	1	25	3	27	0	1038
17:30	31	335	21	6	24	7	42	1	12	302	42	0	17	8	26	0	874
17:45	31	291	19	1	34	11	35	0	14	327	40	0	28	4	24	1	860
Total	116	1267	82	8	129	36	150	2	71	1457	169	3	89	20	100	1	3700
Grand Total	629	8149	678	49	718	208	783	9	568	8253	998	20	537	155	689	3	22446
Apprch %	6.6	85.7	7.1	0.5	41.8	12.1	45.6	0.5	5.8	83.9	10.1	0.2	38.8	11.2	49.8	0.2	
Total	2.8	36.3	3	0.2	3.2	0.9	3.5	0	2.5	36.8	4.4	0.1	2.4	0.7	3.1	0	
Unshifted	624	8032	676	49	715	208	777	9	568	8148	995	20	532	155	688	3	22199
% Unshifted	99.2	98.6	99.7	100	99.6	100	99.2	100	100	98.7	99.7	100	99.1	100	99.9	100	98.9
Heavy Veh	5	117	2	0	3	0	6	0	0	105	3	0	5	0	1	0	247
% Heavy Veh	0.8	1.4	0.3	0	0.4	0	0.8	0	0	1.3	0.3	0	0.9	0	0.1	0	1.1

SEH CONSULTING  
Traffic Data Collection  
TURN MOVEMENT COUNT

TH-51 / Snelling Ave at HarMar Mall entr  
Ref.Pt.: 007.155  
data by SEH  
TURN MOVEMENT COUNT

File Name : TH-51 at HarMar entrance 2008  
Site Code : 00000181  
Start Date : 11/19/2008  
Page No : 2

Start Time	TH-51 / Snelling Ave. Southbound					HarMar entrance Westbound					TH-51 / Snelling Ave. Northbound					W Frontage Road connector Eastbound					Int. Total
	Left	Thru	Right	Peds	App. Total	Left	Thru	Right	Peds	App. Total	Left	Thru	Right	Peds	App. Total	Left	Thru	Right	Peds	App. Total	
Peak Hour Analysis From 06:00 to 08:45 - Peak 1 of 1																					
Peak Hour for Entire Intersection Begins at 07:15																					
07:15	5	365	25	1	396	6	5	4	0	15	14	188	5	0	207	9	2	29	0	40	658
07:30	3	376	22	10	411	4	5	6	1	16	8	239	6	0	253	12	4	21	1	38	718
07:45	3	397	27	0	427	6	0	6	0	12	20	261	8	0	289	12	2	28	0	42	770
08:00	7	327	22	0	356	6	0	3	0	9	16	228	11	0	255	12	4	19	0	35	655
Total Volume	18	1465	96	11	1590	22	10	19	1	52	58	916	30	0	1004	45	12	97	1	155	2801
% App. Total	1.1	92.1	6	0.7		42.3	19.2	36.5	1.9		5.8	91.2	3	0		29	7.7	62.6	0.6		
PHF	.643	.923	.889	.275	.931	.917	.500	.792	.250	.813	.725	.877	.682	.000	.869	.938	.750	.836	.250	.923	.909

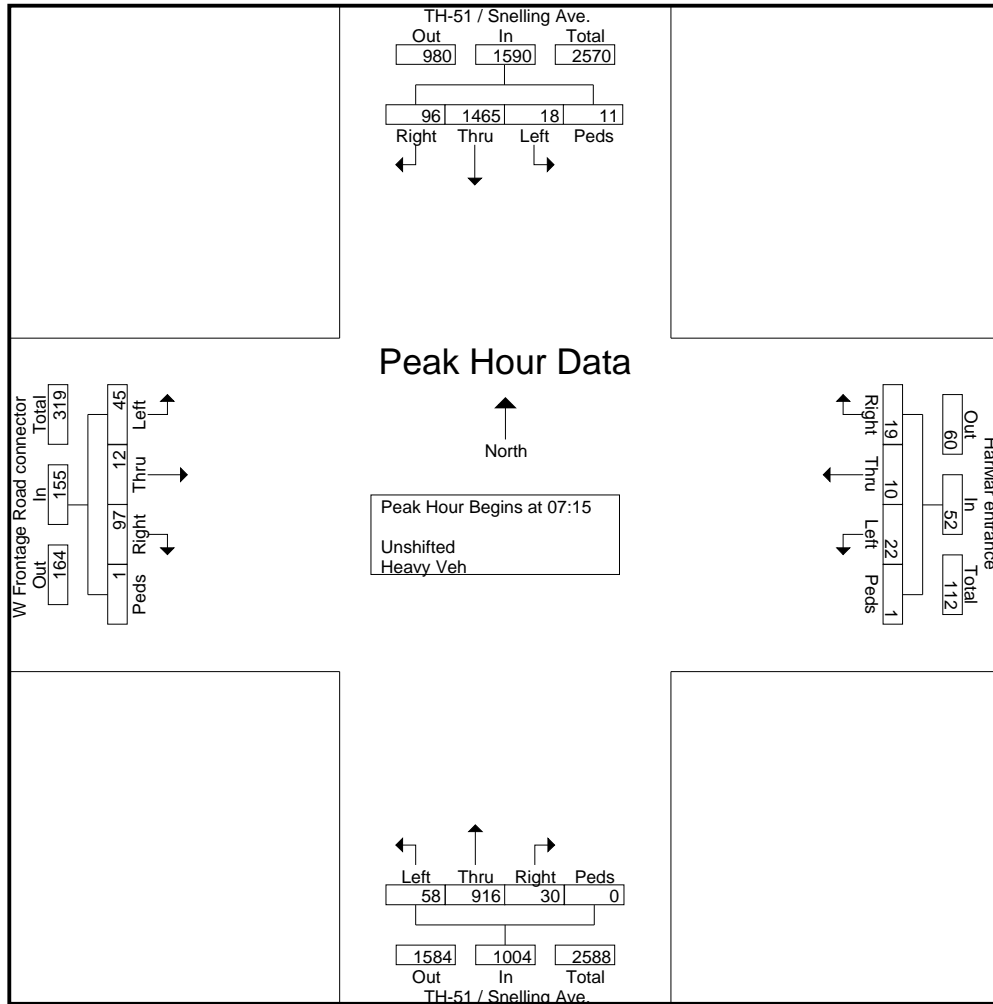

SEH CONSULTING  
Traffic Data Collection  
TURN MOVEMENT COUNT

TH-51 / Snelling Ave at HarMar Mall entr  
Ref.Pt.: 007.155  
data by SEH  
TURN MOVEMENT COUNT

File Name : TH-51 at HarMar entrance 2008  
Site Code : 00000181  
Start Date : 11/19/2008  
Page No : 3

Start Time	TH-51 / Snelling Ave. Southbound					HarMar entrance Westbound					TH-51 / Snelling Ave. Northbound					W Frontage Road connector Eastbound					Int. Total
	Left	Thru	Right	Peds	App. Total	Left	Thru	Right	Peds	App. Total	Left	Thru	Right	Peds	App. Total	Left	Thru	Right	Peds	App. Total	

Peak Hour Analysis From 15:00 to 17:45 - Peak 1 of 1

Peak Hour for Entire Intersection Begins at 16:30

16:30	25	274	15	0	314	28	15	37	0	80	18	433	50	1	502	15	4	23	0	42	938
16:45	27	261	21	3	312	34	6	42	1	83	25	455	46	1	527	18	12	21	0	51	973
17:00	29	304	17	1	351	37	8	44	1	90	22	374	42	2	440	19	5	23	0	47	928
17:15	25	337	25	0	387	34	10	29	0	73	23	454	45	1	523	25	3	27	0	55	1038
Total Volume	106	1176	78	4	1364	133	39	152	2	326	88	1716	183	5	1992	77	24	94	0	195	3877
% App. Total	7.8	86.2	5.7	0.3		40.8	12	46.6	0.6		4.4	86.1	9.2	0.3		39.5	12.3	48.2	0		
PHF	.914	.872	.780	.333	.881	.899	.650	.864	.500	.906	.880	.943	.915	.625	.945	.770	.500	.870	.000	.886	.934

