

# Short Elliott Hendrickson Inc.

3535 Vadnais Center Drive  
St. Paul, MN 55110

"Building a Better World for All of Us"



## TRAFFIC DATA

TH 52 & Upper 55th St W Ramp

Ref.Pt.: 125.929

Data By: Short Elliott Hendrickson, Inc.

TURN MOVEMENT COUNT

File Name : TH 52 & Upper 55th W Ramp 2019

Site Code : 3a

Start Date : 5/2/2019

Page No : 1

### Groups Printed- Vehicles - Trucks

| Start Time | Southbound |      |       |      |            | Westbound |      |       |      |            | Northbound |      |       |      |            | Eastbound |      |       |      |            | Int. Total |
|------------|------------|------|-------|------|------------|-----------|------|-------|------|------------|------------|------|-------|------|------------|-----------|------|-------|------|------------|------------|
|            | Left       | Thru | Right | Peds | App. Total | Left      | Thru | Right | Peds | App. Total | Left       | Thru | Right | Peds | App. Total | Left      | Thru | Right | Peds | App. Total |            |
| 06:00      | 2          | 1    | 0     | 0    | 3          | 20        | 9    | 8     | 0    | 37         | 6          | 9    | 16    | 0    | 31         | 1         | 19   | 5     | 0    | 25         | 96         |
| 06:15      | 2          | 2    | 1     | 0    | 5          | 9         | 21   | 9     | 0    | 39         | 5          | 16   | 39    | 0    | 60         | 0         | 40   | 7     | 0    | 47         | 151        |
| 06:30      | 1          | 0    | 1     | 0    | 2          | 19        | 23   | 12    | 0    | 54         | 4          | 20   | 43    | 0    | 67         | 0         | 38   | 10    | 0    | 48         | 171        |
| 06:45      | 0          | 1    | 1     | 0    | 2          | 9         | 28   | 23    | 0    | 60         | 10         | 32   | 46    | 0    | 88         | 0         | 48   | 4     | 2    | 54         | 204        |
| Total      | 5          | 4    | 3     | 0    | 12         | 57        | 81   | 52    | 0    | 190        | 25         | 77   | 144   | 0    | 246        | 1         | 145  | 26    | 2    | 174        | 622        |
| 07:00      | 5          | 0    | 0     | 0    | 5          | 17        | 26   | 21    | 0    | 64         | 5          | 29   | 44    | 0    | 78         | 1         | 41   | 18    | 2    | 62         | 209        |
| 07:15      | 2          | 1    | 0     | 0    | 3          | 18        | 23   | 30    | 0    | 71         | 14         | 39   | 70    | 0    | 123        | 0         | 44   | 18    | 0    | 62         | 259        |
| 07:30      | 5          | 0    | 0     | 0    | 5          | 19        | 31   | 24    | 0    | 74         | 5          | 53   | 61    | 0    | 119        | 0         | 50   | 15    | 1    | 66         | 264        |
| 07:45      | 0          | 2    | 0     | 0    | 2          | 26        | 39   | 40    | 0    | 105        | 13         | 49   | 65    | 0    | 127        | 1         | 55   | 9     | 1    | 66         | 300        |
| Total      | 12         | 3    | 0     | 0    | 15         | 80        | 119  | 115   | 0    | 314        | 37         | 170  | 240   | 0    | 447        | 2         | 190  | 60    | 4    | 256        | 1032       |
| 08:00      | 4          | 0    | 0     | 0    | 4          | 17        | 38   | 31    | 0    | 86         | 13         | 50   | 78    | 0    | 141        | 0         | 45   | 11    | 0    | 56         | 287        |
| 08:15      | 5          | 5    | 1     | 0    | 11         | 23        | 49   | 22    | 0    | 94         | 16         | 40   | 65    | 0    | 121        | 1         | 53   | 12    | 1    | 67         | 293        |
| 08:30      | 9          | 1    | 2     | 0    | 12         | 15        | 33   | 15    | 0    | 63         | 9          | 31   | 74    | 0    | 114        | 1         | 58   | 7     | 0    | 66         | 255        |
| 08:45      | 8          | 1    | 0     | 0    | 9          | 17        | 48   | 7     | 0    | 72         | 9          | 24   | 75    | 0    | 108        | 1         | 49   | 4     | 0    | 54         | 243        |
| Total      | 26         | 7    | 3     | 0    | 36         | 72        | 168  | 75    | 0    | 315        | 47         | 145  | 292   | 0    | 484        | 3         | 205  | 34    | 1    | 243        | 1078       |
| 09:00      | 5          | 0    | 1     | 0    | 6          | 14        | 38   | 7     | 0    | 59         | 7          | 16   | 59    | 1    | 83         | 0         | 44   | 9     | 1    | 54         | 202        |
| 09:15      | 6          | 2    | 5     | 0    | 13         | 13        | 27   | 14    | 0    | 54         | 8          | 9    | 68    | 0    | 85         | 1         | 36   | 8     | 0    | 45         | 197        |
| 09:30      | 8          | 2    | 1     | 0    | 11         | 16        | 32   | 6     | 0    | 54         | 12         | 15   | 82    | 0    | 109        | 0         | 51   | 11    | 0    | 62         | 236        |
| 09:45      | 6          | 0    | 0     | 0    | 6          | 21        | 32   | 8     | 0    | 61         | 10         | 8    | 90    | 0    | 108        | 0         | 41   | 12    | 0    | 53         | 228        |
| Total      | 25         | 4    | 7     | 0    | 36         | 64        | 129  | 35    | 0    | 228        | 37         | 48   | 299   | 1    | 385        | 1         | 172  | 40    | 1    | 214        | 863        |
| 10:00      | 8          | 2    | 3     | 0    | 13         | 11        | 28   | 11    | 0    | 50         | 7          | 5    | 68    | 0    | 80         | 2         | 35   | 7     | 0    | 44         | 187        |
| 10:15      | 11         | 0    | 2     | 0    | 13         | 13        | 48   | 2     | 0    | 63         | 12         | 7    | 88    | 0    | 107        | 1         | 59   | 12    | 0    | 72         | 255        |
| 10:30      | 9          | 2    | 2     | 0    | 13         | 16        | 40   | 9     | 0    | 65         | 10         | 9    | 68    | 0    | 87         | 2         | 48   | 18    | 0    | 68         | 233        |
| 10:45      | 14         | 4    | 2     | 0    | 20         | 20        | 36   | 7     | 0    | 63         | 5          | 15   | 79    | 0    | 99         | 3         | 48   | 14    | 0    | 65         | 247        |
| Total      | 42         | 8    | 9     | 0    | 59         | 60        | 152  | 29    | 0    | 241        | 34         | 36   | 303   | 0    | 373        | 8         | 190  | 51    | 0    | 249        | 922        |
| 11:00      | 13         | 3    | 2     | 0    | 18         | 14        | 38   | 5     | 0    | 57         | 4          | 6    | 103   | 0    | 113        | 2         | 51   | 10    | 0    | 63         | 251        |
| 11:15      | 13         | 2    | 1     | 0    | 16         | 10        | 46   | 9     | 0    | 65         | 11         | 11   | 79    | 0    | 101        | 2         | 58   | 14    | 0    | 74         | 256        |
| 11:30      | 19         | 4    | 3     | 0    | 26         | 21        | 38   | 9     | 0    | 68         | 13         | 8    | 94    | 0    | 115        | 1         | 63   | 11    | 0    | 75         | 284        |
| 11:45      | 16         | 3    | 4     | 0    | 23         | 19        | 51   | 8     | 0    | 78         | 9          | 7    | 130   | 0    | 146        | 1         | 65   | 15    | 0    | 81         | 328        |
| Total      | 61         | 12   | 10    | 0    | 83         | 64        | 173  | 31    | 0    | 268        | 37         | 32   | 406   | 0    | 475        | 6         | 237  | 50    | 0    | 293        | 1119       |
| 12:00      | 21         | 4    | 2     | 2    | 29         | 23        | 39   | 8     | 0    | 70         | 15         | 7    | 97    | 0    | 119        | 0         | 50   | 6     | 0    | 56         | 274        |
| 12:15      | 15         | 4    | 1     | 0    | 20         | 17        | 43   | 24    | 2    | 86         | 9          | 12   | 102   | 2    | 125        | 4         | 50   | 15    | 1    | 70         | 301        |
| 12:30      | 15         | 2    | 3     | 0    | 20         | 23        | 37   | 16    | 0    | 76         | 7          | 8    | 77    | 0    | 92         | 0         | 63   | 9     | 3    | 75         | 263        |
| 12:45      | 15         | 2    | 3     | 2    | 22         | 24        | 47   | 16    | 0    | 87         | 14         | 15   | 98    | 0    | 127        | 2         | 66   | 14    | 4    | 86         | 322        |
| Total      | 66         | 12   | 9     | 4    | 91         | 87        | 166  | 64    | 2    | 319        | 45         | 42   | 374   | 2    | 463        | 6         | 229  | 44    | 8    | 287        | 1160       |
| 13:00      | 12         | 4    | 3     | 0    | 19         | 16        | 47   | 17    | 0    | 80         | 8          | 13   | 82    | 0    | 103        | 2         | 64   | 12    | 4    | 82         | 284        |
| 13:15      | 8          | 2    | 3     | 1    | 14         | 22        | 49   | 11    | 0    | 82         | 13         | 8    | 98    | 0    | 119        | 1         | 50   | 11    | 0    | 62         | 277        |
| 13:30      | 9          | 3    | 0     | 1    | 13         | 20        | 52   | 7     | 0    | 79         | 8          | 14   | 99    | 0    | 121        | 0         | 59   | 14    | 3    | 76         | 289        |
| 13:45      | 12         | 5    | 2     | 0    | 19         | 16        | 54   | 8     | 0    | 78         | 9          | 15   | 111   | 0    | 135        | 0         | 71   | 8     | 0    | 79         | 311        |
| Total      | 41         | 14   | 8     | 2    | 65         | 74        | 202  | 43    | 0    | 319        | 38         | 50   | 390   | 0    | 478        | 3         | 244  | 45    | 7    | 299        | 1161       |

# Short Elliott Hendrickson Inc.

3535 Vadnais Center Drive  
St. Paul, MN 55110

"Building a Better World for All of Us"



## TRAFFIC DATA

TH 52 & Upper 55th St W Ramp

Ref.Pt.: 125.929

Data By: Short Elliott Hendrickson, Inc.

TURN MOVEMENT COUNT

File Name : TH 52 & Upper 55th W Ramp 2019

Site Code : 3a

Start Date : 5/2/2019

Page No : 2

Groups Printed- Vehicles - Trucks

| Start Time  | Southbound |      |       |      |            | Westbound |      |       |      |            | Northbound |      |       |      |            | Eastbound |      |       |      |            | Int. Total |
|-------------|------------|------|-------|------|------------|-----------|------|-------|------|------------|------------|------|-------|------|------------|-----------|------|-------|------|------------|------------|
|             | Left       | Thru | Right | Peds | App. Total | Left      | Thru | Right | Peds | App. Total | Left       | Thru | Right | Peds | App. Total | Left      | Thru | Right | Peds | App. Total |            |
| 14:00       | 15         | 4    | 2     | 0    | 21         | 31        | 39   | 10    | 0    | 80         | 10         | 8    | 105   | 0    | 123        | 3         | 47   | 22    | 0    | 72         | 296        |
| 14:15       | 21         | 5    | 1     | 2    | 29         | 13        | 52   | 6     | 0    | 71         | 15         | 2    | 91    | 0    | 108        | 3         | 58   | 15    | 0    | 76         | 284        |
| 14:30       | 18         | 4    | 3     | 0    | 25         | 23        | 43   | 10    | 0    | 76         | 5          | 8    | 93    | 0    | 106        | 2         | 63   | 14    | 0    | 79         | 286        |
| 14:45       | 14         | 1    | 3     | 0    | 18         | 17        | 67   | 8     | 0    | 92         | 17         | 12   | 96    | 0    | 125        | 3         | 81   | 19    | 0    | 103        | 338        |
| Total       | 68         | 14   | 9     | 2    | 93         | 84        | 201  | 34    | 0    | 319        | 47         | 30   | 385   | 0    | 462        | 11        | 249  | 70    | 0    | 330        | 1204       |
| 15:00       | 20         | 6    | 1     | 0    | 27         | 11        | 68   | 8     | 0    | 87         | 20         | 11   | 106   | 0    | 137        | 0         | 79   | 19    | 0    | 98         | 349        |
| 15:15       | 14         | 4    | 2     | 0    | 20         | 14        | 45   | 6     | 0    | 65         | 22         | 10   | 108   | 0    | 140        | 2         | 64   | 15    | 1    | 82         | 307        |
| 15:30       | 22         | 13   | 3     | 0    | 38         | 31        | 52   | 6     | 0    | 89         | 24         | 5    | 117   | 0    | 146        | 0         | 69   | 27    | 1    | 97         | 370        |
| 15:45       | 17         | 8    | 6     | 0    | 31         | 24        | 52   | 3     | 0    | 79         | 15         | 10   | 150   | 0    | 175        | 3         | 74   | 15    | 0    | 92         | 377        |
| Total       | 73         | 31   | 12    | 0    | 116        | 80        | 217  | 23    | 0    | 320        | 81         | 36   | 481   | 0    | 598        | 5         | 286  | 76    | 2    | 369        | 1403       |
| 16:00       | 58         | 21   | 7     | 0    | 86         | 34        | 70   | 11    | 0    | 115        | 17         | 7    | 148   | 0    | 172        | 2         | 79   | 20    | 0    | 101        | 474        |
| 16:15       | 26         | 18   | 6     | 0    | 50         | 37        | 45   | 13    | 0    | 95         | 24         | 4    | 185   | 0    | 213        | 2         | 75   | 17    | 0    | 94         | 452        |
| 16:30       | 53         | 16   | 3     | 0    | 72         | 30        | 58   | 8     | 0    | 96         | 16         | 10   | 176   | 0    | 202        | 4         | 102  | 21    | 0    | 127        | 497        |
| 16:45       | 40         | 31   | 4     | 0    | 75         | 44        | 66   | 6     | 0    | 116        | 14         | 8    | 214   | 0    | 236        | 2         | 79   | 29    | 2    | 112        | 539        |
| Total       | 177        | 86   | 20    | 0    | 283        | 145       | 239  | 38    | 0    | 422        | 71         | 29   | 723   | 0    | 823        | 10        | 335  | 87    | 2    | 434        | 1962       |
| 17:00       | 39         | 21   | 5     | 0    | 65         | 43        | 61   | 9     | 0    | 113        | 19         | 10   | 187   | 0    | 216        | 2         | 116  | 21    | 1    | 140        | 534        |
| 17:15       | 29         | 9    | 5     | 0    | 43         | 28        | 56   | 2     | 0    | 86         | 22         | 3    | 164   | 0    | 189        | 0         | 89   | 23    | 0    | 112        | 430        |
| 17:30       | 19         | 7    | 4     | 2    | 32         | 23        | 55   | 11    | 0    | 89         | 26         | 4    | 165   | 0    | 195        | 2         | 87   | 18    | 3    | 110        | 426        |
| 17:45       | 11         | 3    | 2     | 0    | 16         | 33        | 50   | 7     | 0    | 90         | 10         | 7    | 153   | 0    | 170        | 0         | 86   | 16    | 0    | 102        | 378        |
| Total       | 98         | 40   | 16    | 2    | 156        | 127       | 222  | 29    | 0    | 378        | 77         | 24   | 669   | 0    | 770        | 4         | 378  | 78    | 4    | 464        | 1768       |
| 18:00       | 11         | 2    | 2     | 0    | 15         | 20        | 60   | 9     | 0    | 89         | 14         | 4    | 103   | 0    | 121        | 0         | 88   | 10    | 2    | 100        | 325        |
| 18:15       | 8          | 3    | 1     | 1    | 13         | 27        | 43   | 5     | 0    | 75         | 13         | 5    | 93    | 0    | 111        | 0         | 70   | 17    | 1    | 88         | 287        |
| 18:30       | 7          | 1    | 1     | 0    | 9          | 24        | 48   | 2     | 0    | 74         | 13         | 1    | 89    | 0    | 103        | 0         | 64   | 3     | 0    | 67         | 253        |
| 18:45       | 8          | 0    | 2     | 0    | 10         | 13        | 43   | 3     | 0    | 59         | 10         | 3    | 74    | 0    | 87         | 0         | 61   | 6     | 0    | 67         | 223        |
| Total       | 34         | 6    | 6     | 1    | 47         | 84        | 194  | 19    | 0    | 297        | 50         | 13   | 359   | 0    | 422        | 0         | 283  | 36    | 3    | 322        | 1088       |
| Grand Total | 728        | 241  | 112   | 11   | 1092       | 1078      | 2263 | 587   | 2    | 3930       | 626        | 732  | 5065  | 3    | 6426       | 60        | 3143 | 697   | 34   | 3934       | 15382      |
| Apprch %    | 66.7       | 22.1 | 10.3  | 1    |            | 27.4      | 57.6 | 14.9  | 0.1  |            | 9.7        | 11.4 | 78.8  | 0    |            | 1.5       | 79.9 | 17.7  | 0.9  |            |            |
| Total %     | 4.7        | 1.6  | 0.7   | 0.1  | 7.1        | 7         | 14.7 | 3.8   | 0    | 25.5       | 4.1        | 4.8  | 32.9  | 0    | 41.8       | 0.4       | 20.4 | 4.5   | 0.2  | 25.6       |            |
| Vehicles    | 712        | 236  | 109   | 11   | 1068       | 1035      | 2169 |       |      |            |            |      | 4879  |      |            |           | 3093 |       |      |            | 14906      |
| % Vehicles  | 97.8       | 97.9 | 97.3  | 100  | 97.8       | 96        | 95.8 | 99    | 100  | 96.4       | 99.5       | 98.2 | 96.3  | 66.7 | 96.8       | 95        | 98.4 | 92.5  | 97.1 | 97.3       | 96.9       |
| Trucks      | 16         | 5    | 3     | 0    | 24         | 43        | 94   | 6     | 0    | 143        | 3          | 13   | 186   | 1    | 203        | 3         | 50   | 52    | 1    | 106        | 476        |
| % Trucks    | 2.2        | 2.1  | 2.7   | 0    | 2.2        | 4         | 4.2  | 1     | 0    | 3.6        | 0.5        | 1.8  | 3.7   | 33.3 | 3.2        | 5         | 1.6  | 7.5   | 2.9  | 2.7        | 3.1        |

# Short Elliott Hendrickson Inc.

3535 Vadnais Center Drive  
St. Paul, MN 55110

"Building a Better World for All of Us"



## TRAFFIC DATA

TH 52 & Upper 55th St W Ramp

Ref.Pt.: 125.929

Data By: Short Elliott Hendrickson, Inc.

TURN MOVEMENT COUNT

File Name : TH 52 & Upper 55th W Ramp 2019

Site Code : 3a

Start Date : 5/2/2019

Page No : 3

| Start Time   | Southbound |      |       |      |            | Westbound |      |       |      |            | Northbound |      |       |      |            | Eastbound |      |       |      |            | Int. Total |
|--|------------|------|-------|------|------------|-----------|------|-------|------|------------|------------|------|-------|------|------------|-----------|------|-------|------|------------|------------|
|  | Left       | Thru | Right | Peds | App. Total | Left      | Thru | Right | Peds | App. Total | Left       | Thru | Right | Peds | App. Total | Left      | Thru | Right | Peds | App. Total |            |
| Peak Hour Analysis From 06:00 to 08:45 - Peak 1 of 1 |            |      |       |      |            |           |      |       |      |            |            |      |       |      |            |           |      |       |      |            |            |
| Peak Hour for Entire Intersection Begins at 07:30    |            |      |       |      |            |           |      |       |      |            |            |      |       |      |            |           |      |       |      |            |            |
| 07:30  | 5          | 0    | 0     | 0    | 5          | 19        | 31   | 24    | 0    | 74         | 5          | 53   | 61    | 0    | 119        | 0         | 50   | 15    | 1    | 66         | 264        |
| 07:45  | 0          | 2    | 0     | 0    | 2          | 26        | 39   | 40    | 0    | 105        | 13         | 49   | 65    | 0    | 127        | 1         | 55   | 9     | 1    | 66         | 300        |
| 08:00  | 4          | 0    | 0     | 0    | 4          | 17        | 38   | 31    | 0    | 86         | 13         | 50   | 78    | 0    | 141        | 0         | 45   | 11    | 0    | 56         | 287        |
| 08:15  | 5          | 5    | 1     | 0    | 11         | 23        | 49   | 22    | 0    | 94         | 16         | 40   | 65    | 0    | 121        | 1         | 53   | 12    | 1    | 67         | 293        |
| Total Volume   | 14         | 7    | 1     | 0    | 22         | 85        | 157  | 117   | 0    | 359        | 47         | 192  | 269   | 0    | 508        | 2         | 203  | 47    | 3    | 255        | 1144       |
| % App. Total   | 63.6       | 31.8 | 4.5   | 0    |            | 23.7      | 43.7 | 32.6  | 0    |            | 9.3        | 37.8 | 53    | 0    |            | 0.8       | 79.6 | 18.4  | 1.2  |            |            |
| PHF  | .700       | .350 | .250  | .000 | .500       | .817      | .801 | .731  | .000 | .855       | .734       | .906 | .862  | .000 | .901       | .500      | .923 | .783  | .750 | .951       | .953       |

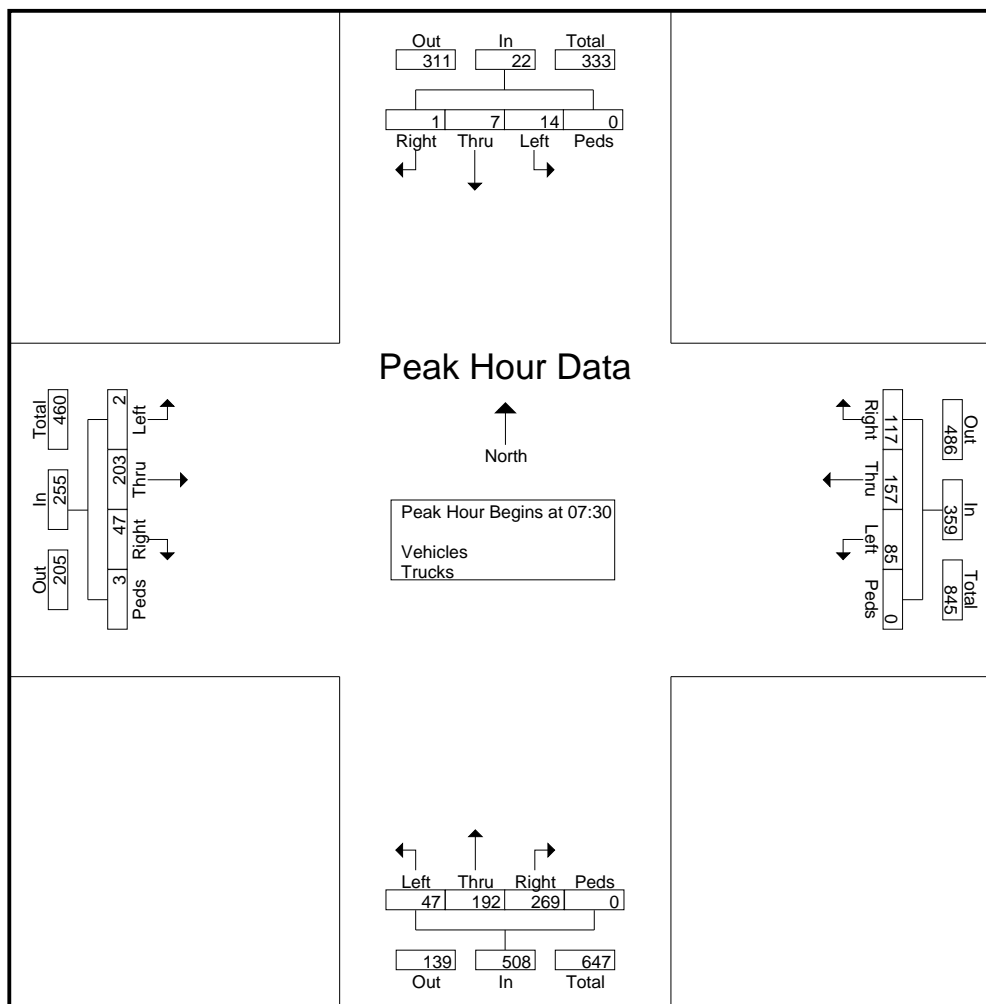

# Short Elliott Hendrickson Inc.

3535 Vadnais Center Drive  
St. Paul, MN 55110

"Building a Better World for All of Us"



## TRAFFIC DATA

TH 52 & Upper 55th St W Ramp

Ref.Pt.: 125.929

Data By: Short Elliott Hendrickson, Inc.

TURN MOVEMENT COUNT

File Name : TH 52 & Upper 55th W Ramp 2019

Site Code : 3a

Start Date : 5/2/2019

Page No : 4

| Start Time   | Southbound |      |       |      |            | Westbound |      |       |      |            | Northbound |      |       |      |            | Eastbound |      |       |      |            | Int. Total |
|--|------------|------|-------|------|------------|-----------|------|-------|------|------------|------------|------|-------|------|------------|-----------|------|-------|------|------------|------------|
|  | Left       | Thru | Right | Peds | App. Total | Left      | Thru | Right | Peds | App. Total | Left       | Thru | Right | Peds | App. Total | Left      | Thru | Right | Peds | App. Total |            |
| Peak Hour Analysis From 11:00 to 12:45 - Peak 1 of 1 |            |      |       |      |            |           |      |       |      |            |            |      |       |      |            |           |      |       |      |            |            |
| Peak Hour for Entire Intersection Begins at 11:30    |            |      |       |      |            |           |      |       |      |            |            |      |       |      |            |           |      |       |      |            |            |
| 11:30  | 19         | 4    | 3     | 0    | 26         | 21        | 38   | 9     | 0    | 68         | 13         | 8    | 94    | 0    | 115        | 1         | 63   | 11    | 0    | 75         | 284        |
| 11:45  | 16         | 3    | 4     | 0    | 23         | 19        | 51   | 8     | 0    | 78         | 9          | 7    | 130   | 0    | 146        | 1         | 65   | 15    | 0    | 81         | 328        |
| 12:00  | 21         | 4    | 2     | 2    | 29         | 23        | 39   | 8     | 0    | 70         | 15         | 7    | 97    | 0    | 119        | 0         | 50   | 6     | 0    | 56         | 274        |
| 12:15  | 15         | 4    | 1     | 0    | 20         | 17        | 43   | 24    | 2    | 86         | 9          | 12   | 102   | 2    | 125        | 4         | 50   | 15    | 1    | 70         | 301        |
| Total Volume   | 71         | 15   | 10    | 2    | 98         | 80        | 171  | 49    | 2    | 302        | 46         | 34   | 423   | 2    | 505        | 6         | 228  | 47    | 1    | 282        | 1187       |
| % App. Total   | 72.4       | 15.3 | 10.2  | 2    |            | 26.5      | 56.6 | 16.2  | 0.7  |            | 9.1        | 6.7  | 83.8  | 0.4  |            | 2.1       | 80.9 | 16.7  | 0.4  |            |            |
| PHF  | .845       | .938 | .625  | .250 | .845       | .870      | .838 | .510  | .250 | .878       | .767       | .708 | .813  | .250 | .865       | .375      | .877 | .783  | .250 | .870       | .905       |

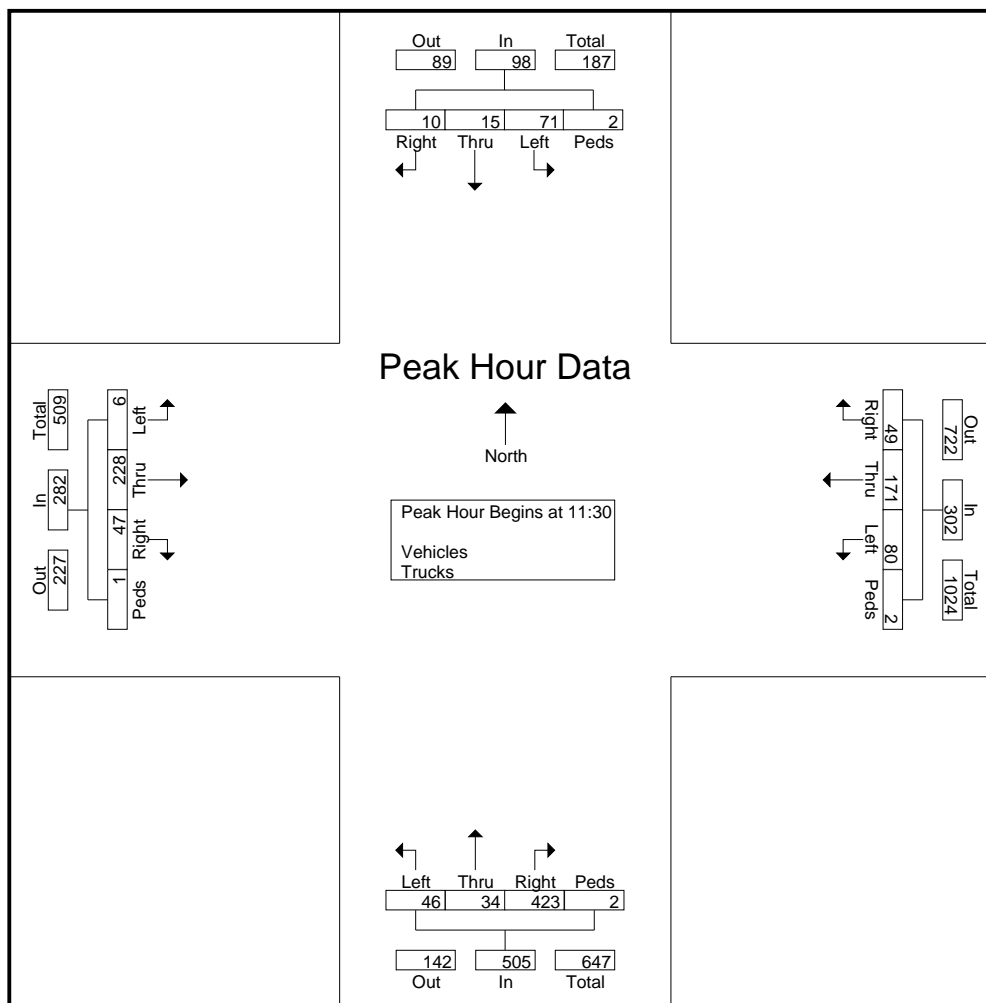

# Short Elliott Hendrickson Inc.

3535 Vadnais Center Drive  
St. Paul, MN 55110

"Building a Better World for All of Us"



## TRAFFIC DATA

TH 52 & Upper 55th St W Ramp

Ref.Pt.: 125.929

Data By: Short Elliott Hendrickson, Inc.

TURN MOVEMENT COUNT

File Name : TH 52 & Upper 55th W Ramp 2019

Site Code : 3a

Start Date : 5/2/2019

Page No : 5

| Start Time   | Southbound |      |       |      |            | Westbound |      |       |      |            | Northbound |      |       |      |            | Eastbound |      |       |      |            | Int. Total |
|--|------------|------|-------|------|------------|-----------|------|-------|------|------------|------------|------|-------|------|------------|-----------|------|-------|------|------------|------------|
|  | Left       | Thru | Right | Peds | App. Total | Left      | Thru | Right | Peds | App. Total | Left       | Thru | Right | Peds | App. Total | Left      | Thru | Right | Peds | App. Total |            |
| Peak Hour Analysis From 15:00 to 17:45 - Peak 1 of 1 |            |      |       |      |            |           |      |       |      |            |            |      |       |      |            |           |      |       |      |            |            |
| Peak Hour for Entire Intersection Begins at 16:15    |            |      |       |      |            |           |      |       |      |            |            |      |       |      |            |           |      |       |      |            |            |
| 16:15  | 26         | 18   | 6     | 0    | 50         | 37        | 45   | 13    | 0    | 95         | 24         | 4    | 185   | 0    | 213        | 2         | 75   | 17    | 0    | 94         | 452        |
| 16:30  | 53         | 16   | 3     | 0    | 72         | 30        | 58   | 8     | 0    | 96         | 16         | 10   | 176   | 0    | 202        | 4         | 102  | 21    | 0    | 127        | 497        |
| 16:45  | 40         | 31   | 4     | 0    | 75         | 44        | 66   | 6     | 0    | 116        | 14         | 8    | 214   | 0    | 236        | 2         | 79   | 29    | 2    | 112        | 539        |
| 17:00  | 39         | 21   | 5     | 0    | 65         | 43        | 61   | 9     | 0    | 113        | 19         | 10   | 187   | 0    | 216        | 2         | 116  | 21    | 1    | 140        | 534        |
| Total Volume   | 158        | 86   | 18    | 0    | 262        | 154       | 230  | 36    | 0    | 420        | 73         | 32   | 762   | 0    | 867        | 10        | 372  | 88    | 3    | 473        | 2022       |
| % App. Total   | 60.3       | 32.8 | 6.9   | 0    |            | 36.7      | 54.8 | 8.6   | 0    |            | 8.4        | 3.7  | 87.9  | 0    |            | 2.1       | 78.6 | 18.6  | 0.6  |            |            |
| PHF  | .745       | .694 | .750  | .000 | .873       | .875      | .871 | .692  | .000 | .905       | .760       | .800 | .890  | .000 | .918       | .625      | .802 | .759  | .375 | .845       | .938       |

