



MINNESOTA DEPT OF TRANSPORTATION

TRAFFIC DATA COLLECTION - METRO

Counted By: Joanne & Joseph
 Day of the Week: Thursday
 Location: TH 55 & Industrial Park
 Project #: 5764

File Name : TH 55 @ INDUSTRIAL PARK BLVD 2006
 Site.Code : 07271112
 Start Date : 7/27/2006
 Page No : 1

Groups Printed- Unshifted

Start Time	Industrial Park Blvd Southbound					TH 55 Westbound					Industrial Park Blvd Northbound					TH 55 Eastbound					Int. Total
	Left	Thru	Right	Peds	App. Total	Left	Thru	Right	Peds	App. Total	Left	Thru	Right	Peds	App. Total	Left	Thru	Right	Peds	App. Total	
06:00	6	1	0	0	7	7	77	5	0	89	1	0	0	0	1	0	197	5	0	202	299
06:15	4	0	0	0	4	9	102	8	0	119	1	0	2	0	3	0	235	7	0	242	368
06:30	2	1	0	0	3	8	159	3	0	170	0	0	3	0	3	2	368	6	0	376	552
06:45	5	5	2	0	12	23	168	9	0	200	2	0	5	0	7	1	447	11	0	459	678
Total	17	7	2	0	26	47	506	25	0	578	4	0	10	0	14	3	1247	29	0	1279	1897
07:00	11	6	0	0	17	8	147	10	0	165	1	3	5	0	9	3	468	12	0	483	674
07:15	13	3	1	0	17	14	225	10	0	249	3	0	3	0	6	5	565	10	0	580	852
07:30	7	5	1	0	13	10	213	8	0	231	2	2	7	0	11	3	679	15	0	697	952
07:45	23	1	1	0	25	11	259	12	0	282	2	3	6	0	11	1	589	14	0	604	922
Total	54	15	3	0	72	43	844	40	0	927	8	8	21	0	37	12	2301	51	0	2364	3400
08:00	8	2	3	0	13	10	244	13	0	267	1	1	14	0	16	5	459	6	0	470	766
08:15	6	5	1	0	12	13	200	15	0	228	1	4	6	0	11	7	444	5	0	456	707
08:30	5	2	3	0	10	8	192	11	0	211	2	3	2	0	7	5	356	2	0	363	591
08:45	8	1	3	0	12	6	233	20	0	259	3	2	5	0	10	6	332	3	0	341	622
Total	27	10	10	0	47	37	869	59	0	965	7	10	27	0	44	23	1591	16	0	1630	2686
11:00	15	5	5	0	25	8	198	7	0	213	6	1	5	0	12	6	191	6	0	203	453
11:15	8	4	4	0	16	4	200	7	0	211	7	3	10	0	20	8	219	12	0	239	486
11:30	14	2	7	0	23	10	225	9	0	244	10	2	16	0	28	5	217	10	0	232	527
11:45	23	0	2	0	25	6	211	10	0	227	8	2	11	0	21	7	242	13	0	262	535
Total	60	11	18	0	89	28	834	33	0	895	31	8	42	0	81	26	869	41	0	936	2001
12:00	10	4	2	0	16	6	210	39	0	255	9	1	13	0	23	1	223	7	1	232	526
12:15	15	2	2	0	19	11	245	12	0	268	6	0	7	0	13	4	215	9	3	231	531
12:30	9	2	5	0	16	8	211	5	0	224	3	1	6	0	10	1	211	7	3	222	472
12:45	11	8	4	0	23	7	243	9	0	259	2	2	4	0	8	2	267	12	1	282	572
Total	45	16	13	0	74	32	909	65	0	1006	20	4	30	0	54	8	916	35	8	967	2101
15:00	6	2	3	0	11	9	299	14	1	323	12	1	21	0	34	1	238	5	1	245	613
15:15	12	2	4	0	18	20	284	27	1	332	11	1	9	0	21	8	217	6	2	233	604
15:30	11	6	1	3	21	29	274	13	0	316	9	1	70	0	80	1	285	7	2	295	712
15:45	9	5	5	0	19	25	149	3	0	177	10	1	11	0	22	2	229	6	1	238	456
Total	38	15	13	3	69	83	1006	57	2	1148	42	4	111	0	157	12	969	24	6	1011	2385
16:00	9	2	5	0	16	11	325	148	0	484	16	0	31	0	47	3	271	5	4	283	830
16:15	8	4	1	2	15	6	245	92	1	344	10	3	15	0	28	4	234	1	1	240	627
16:30	19	2	5	0	26	23	288	19	0	330	7	4	36	0	47	1	309	4	1	315	718
16:45	7	2	6	0	15	10	264	18	4	296	1	5	17	0	23	2	276	4	0	282	616
Total	43	10	17	2	72	50	1122	277	5	1454	34	12	99	0	145	10	1090	14	6	1120	2791
17:00	36	2	7	0	45	14	250	18	0	282	7	0	21	0	28	1	337	3	2	343	698
17:15	13	3	4	0	20	5	420	10	1	436	8	1	10	0	19	1	327	2	2	332	807
17:30	11	9	1	0	21	3	200	8	0	211	7	4	7	0	18	2	280	1	2	285	535
17:45	9	3	3	0	15	2	277	7	0	286	3	3	9	0	15	1	252	1	2	256	572
Total	69	17	15	0	101	24	1147	43	1	1215	25	8	47	0	80	5	1196	7	8	1216	2612
Grand Total	353	101	91	5	550	344	7237	599	8	8188	171	54	387	0	612	99	10179	217	28	10523	19873
Apprch %	64.2	18.4	16.5	0.9		4.2	88.4	7.3	0.1		27.9	8.8	63.2	0		0.9	96.7	2.1	0.3		
Total %	1.8	0.5	0.5	0	2.8	1.7	36.4	3	0	41.2	0.9	0.3	1.9	0	3.1	0.5	51.2	1.1	0.1	53	



MINNESOTA DEPT OF TRANSPORTATION

TRAFFIC DATA COLLECTION - METRO

File Name : TH 55 @ INDUSTRIAL PARK BLVD 2006
 Site.Code : 07271112
 Start Date : 7/27/2006
 Page No : 2

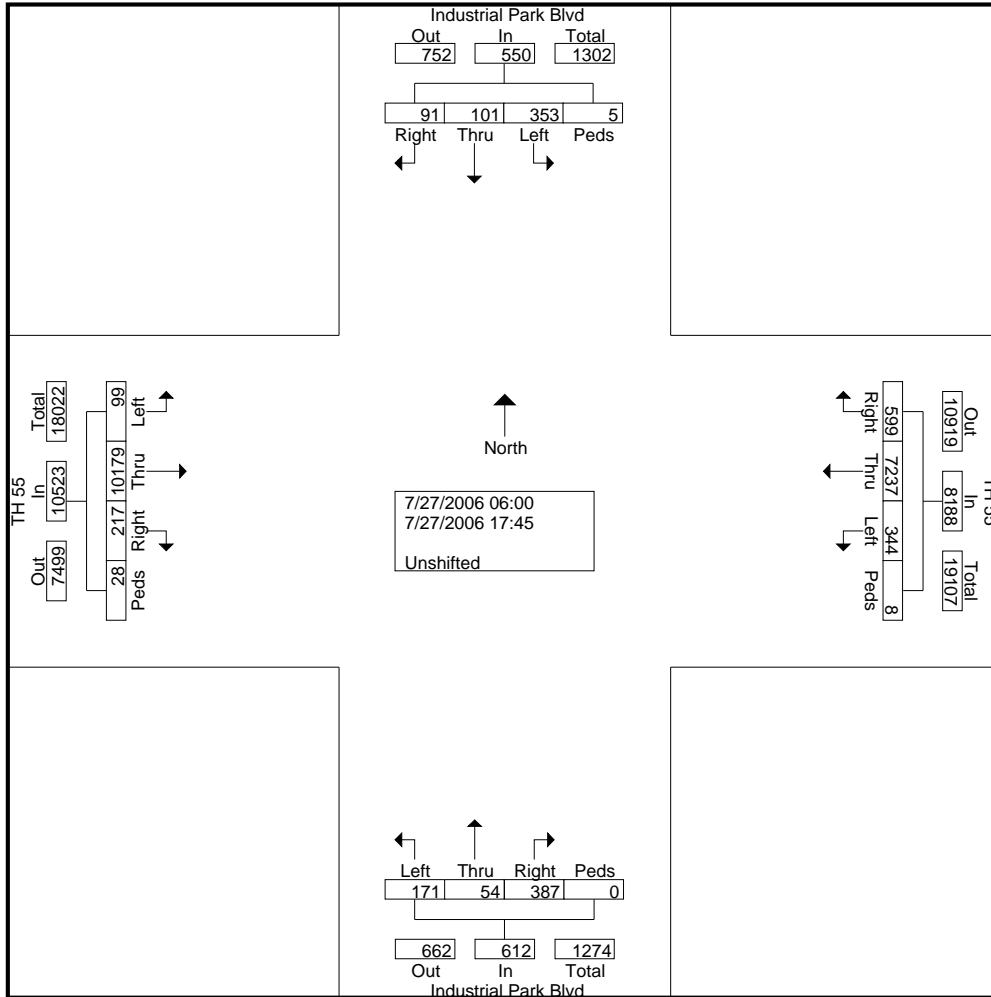



MINNESOTA DEPT OF TRANSPORTATION

TRAFFIC DATA COLLECTION - METRO

File Name : TH 55 @ INDUSTRIAL PARK BLVD 2006
 Site.Code : 07271112
 Start Date : 7/27/2006
 Page No : 3

Start Time	Industrial Park Blvd Southbound					TH 55 Westbound					Industrial Park Blvd Northbound					TH 55 Eastbound					Int. Total
	Left	Thru	Right	Peds	App. Total	Left	Thru	Right	Peds	App. Total	Left	Thru	Right	Peds	App. Total	Left	Thru	Right	Peds	App. Total	
Peak Hour Analysis From 06:00 to 09:45 - Peak 1 of 1																					
Peak Hour for Entire Intersection Begins at 07:15																					
07:15	13	3	1	0	17	14	225	10	0	249	3	0	3	0	6	5	565	10	0	580	852
07:30	7	5	1	0	13	10	213	8	0	231	2	2	7	0	11	3	679	15	0	697	952
07:45	23	1	1	0	25	11	259	12	0	282	2	3	6	0	11	1	589	14	0	604	922
08:00	8	2	3	0	13	10	244	13	0	267	1	1	14	0	16	5	459	6	0	470	766
Total Volume	51	11	6	0	68	45	941	43	0	1029	8	6	30	0	44	14	2292	45	0	2351	3492
% App. Total	75	16.2	8.8	0		4.4	91.4	4.2	0		18.2	13.6	68.2	0		0.6	97.5	1.9	0		
PHF	.554	.550	.500	.000	.680	.804	.908	.827	.000	.912	.667	.500	.536	.000	.688	.700	.844	.750	.000	.843	.917

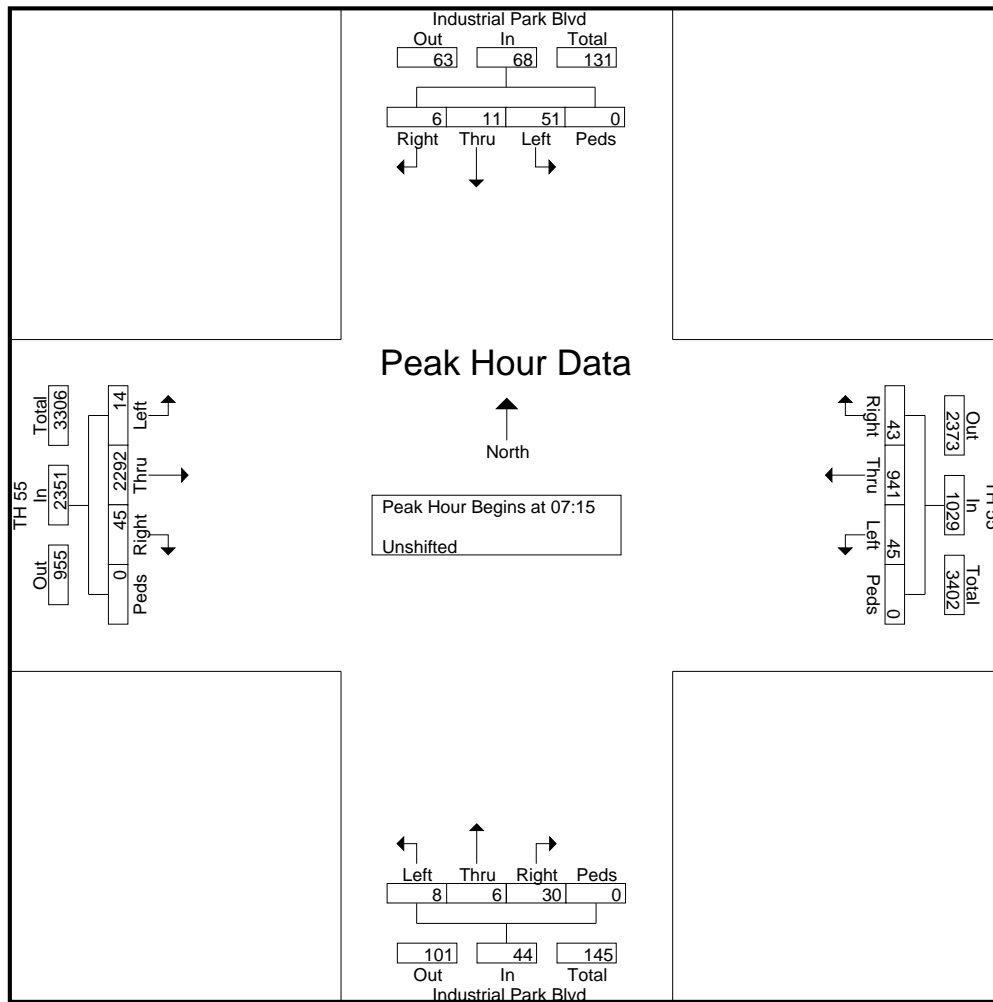



MINNESOTA DEPT OF TRANSPORTATION

TRAFFIC DATA COLLECTION - METRO

File Name : TH 55 @ INDUSTRIAL PARK BLVD 2006
 Site.Code : 07271112
 Start Date : 7/27/2006
 Page No : 4

Start Time	Industrial Park Blvd Southbound					TH 55 Westbound					Industrial Park Blvd Northbound					TH 55 Eastbound					Int. Total
	Left	Thru	Right	Peds	App. Total	Left	Thru	Right	Peds	App. Total	Left	Thru	Right	Peds	App. Total	Left	Thru	Right	Peds	App. Total	
11:30	14	2	7	0	23	10	225	9	0	244	10	2	16	0	28	5	217	10	0	232	527
11:45	23	0	2	0	25	6	211	10	0	227	8	2	11	0	21	7	242	13	0	262	535
12:00	10	4	2	0	16	6	210	39	0	255	9	1	13	0	23	1	223	7	1	232	526
12:15	15	2	2	0	19	11	245	12	0	268	6	0	7	0	13	4	215	9	3	231	531
Total Volume	62	8	13	0	83	33	891	70	0	994	33	5	47	0	85	17	897	39	4	957	2119
% App. Total	74.7	9.6	15.7	0		3.3	89.6	7	0		38.8	5.9	55.3	0		1.8	93.7	4.1	0.4		
PHF	.674	.500	.464	.000	.830	.750	.909	.449	.000	.927	.825	.625	.734	.000	.759	.607	.927	.750	.333	.913	.990

Peak Hour Analysis From 10:00 to 13:45 - Peak 1 of 1
 Peak Hour for Entire Intersection Begins at 11:30

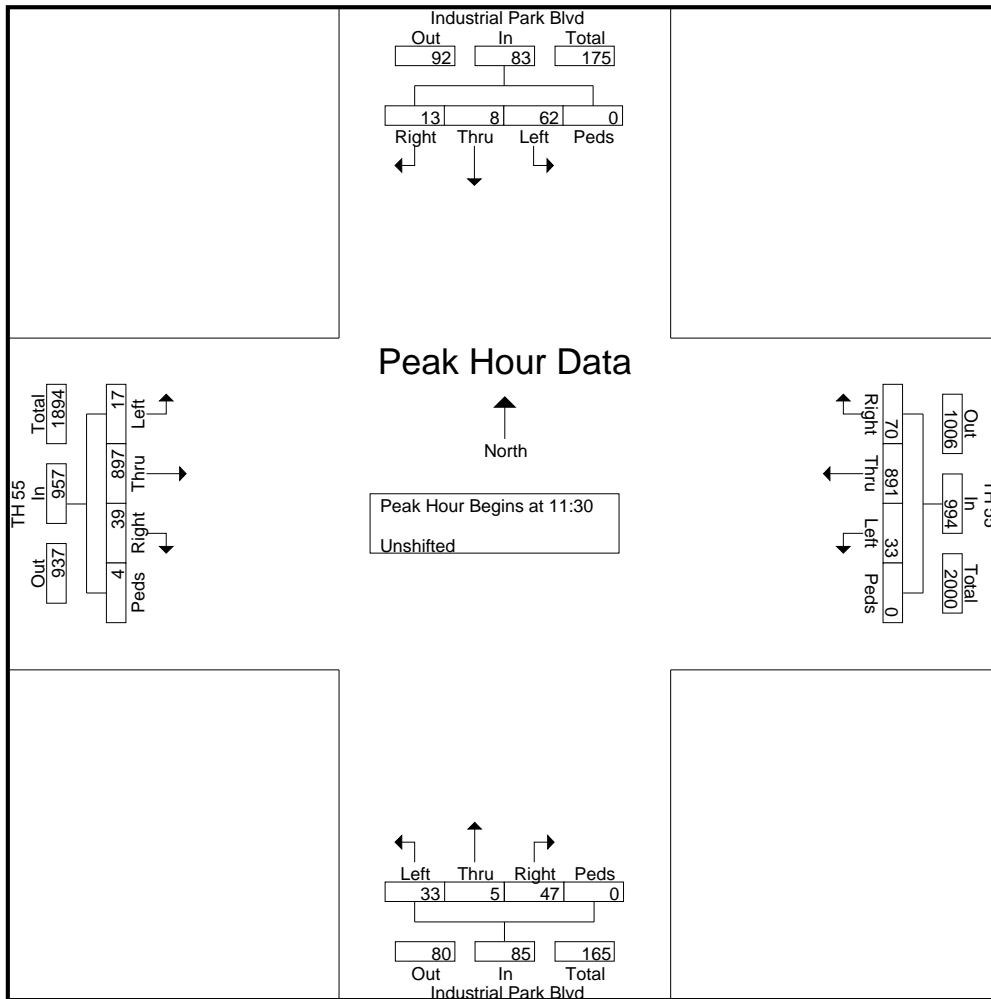



MINNESOTA DEPT OF TRANSPORTATION

TRAFFIC DATA COLLECTION - METRO

File Name : TH 55 @ INDUSTRIAL PARK BLVD 2006
 Site.Code : 07271112
 Start Date : 7/27/2006
 Page No : 5

Start Time	Industrial Park Blvd Southbound					TH 55 Westbound					Industrial Park Blvd Northbound					TH 55 Eastbound					Int. Total
	Left	Thru	Right	Peds	App. Total	Left	Thru	Right	Peds	App. Total	Left	Thru	Right	Peds	App. Total	Left	Thru	Right	Peds	App. Total	
16:30	19	2	5	0	26	23	288	19	0	330	7	4	36	0	47	1	309	4	1	315	718
16:45	7	2	6	0	15	10	264	18	4	296	1	5	17	0	23	2	276	4	0	282	616
17:00	36	2	7	0	45	14	250	18	0	282	7	0	21	0	28	1	337	3	2	343	698
17:15	13	3	4	0	20	5	420	10	1	436	8	1	10	0	19	1	327	2	2	332	807
Total Volume	75	9	22	0	106	52	1222	65	5	1344	23	10	84	0	117	5	1249	13	5	1272	2839
% App. Total	70.8	8.5	20.8	0		3.9	90.9	4.8	0.4		19.7	8.5	71.8	0		0.4	98.2	1	0.4		
PHF	.521	.750	.786	.000	.589	.565	.727	.855	.313	.771	.719	.500	.583	.000	.622	.625	.927	.813	.625	.927	.879

Peak Hour Analysis From 14:00 to 17:45 - Peak 1 of 1
 Peak Hour for Entire Intersection Begins at 16:30

