



MINNESOTA DEPT OF TRANSPORTATION

TRAFFIC DATA COLLECTION - METRO

File Name : TH 55 @ TH 100 RAMPS 2006

Site Code : 08032812

Start Date : 8/3/2006

Page No : 2

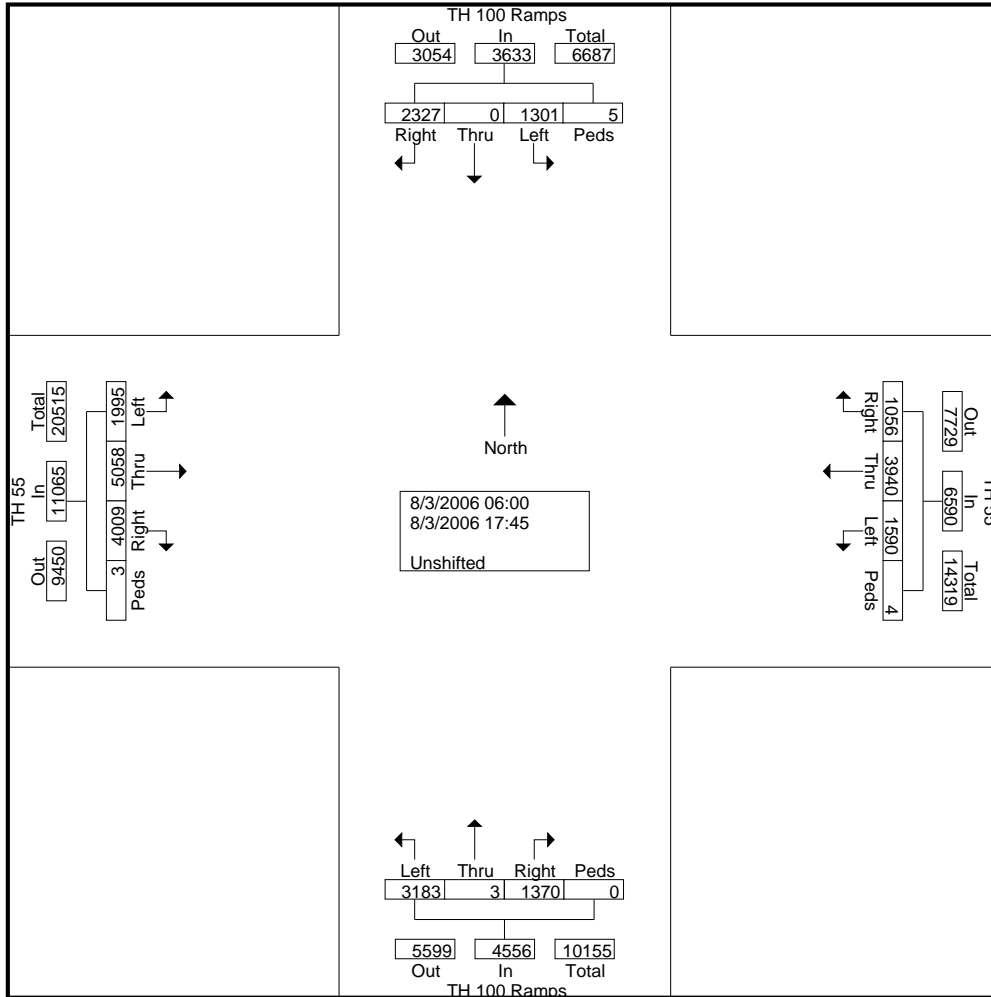



MINNESOTA DEPT OF TRANSPORTATION

TRAFFIC DATA COLLECTION - METRO

File Name : TH 55 @ TH 100 RAMPS 2006
 Site Code : 08032812
 Start Date : 8/3/2006
 Page No : 3

| Start Time | TH 100 Ramps Southbound | | | | | TH 55 Westbound | | | | | TH 100 Ramps Northbound | | | | | TH 55 Eastbound | | | | | Int. Total |
|--|-------------------------|------|-------|------|------------|-----------------|------|-------|------|------------|-------------------------|------|-------|------|------------|-----------------|------|-------|------|------------|------------|
| | Left | Thru | Right | Peds | App. Total | Left | Thru | Right | Peds | App. Total | Left | Thru | Right | Peds | App. Total | Left | Thru | Right | Peds | App. Total | |
| Peak Hour Analysis From 06:00 to 09:45 - Peak 1 of 1 | | | | | | | | | | | | | | | | | | | | | |
| Peak Hour for Entire Intersection Begins at 07:30 | | | | | | | | | | | | | | | | | | | | | |
| 07:30 | 61 | 0 | 67 | 0 | 128 | 44 | 99 | 12 | 0 | 155 | 125 | 0 | 48 | 0 | 173 | 37 | 307 | 114 | 0 | 458 | 914 |
| 07:45 | 101 | 0 | 89 | 1 | 191 | 26 | 125 | 25 | 1 | 177 | 146 | 0 | 73 | 0 | 219 | 47 | 323 | 134 | 0 | 504 | 1091 |
| 08:00 | 85 | 0 | 111 | 0 | 196 | 30 | 143 | 15 | 0 | 188 | 122 | 0 | 74 | 0 | 196 | 37 | 291 | 120 | 2 | 450 | 1030 |
| 08:15 | 83 | 0 | 122 | 0 | 205 | 39 | 106 | 19 | 0 | 164 | 134 | 0 | 50 | 0 | 184 | 40 | 272 | 136 | 0 | 448 | 1001 |
| Total Volume | 330 | 0 | 389 | 1 | 720 | 139 | 473 | 71 | 1 | 684 | 527 | 0 | 245 | 0 | 772 | 161 | 1193 | 504 | 2 | 1860 | 4036 |
| % App. Total | 45.8 | 0 | 54 | 0.1 | | 20.3 | 69.2 | 10.4 | 0.1 | | 68.3 | 0 | 31.7 | 0 | | 8.7 | 64.1 | 27.1 | 0.1 | | |
| PHF | .817 | .000 | .797 | .250 | .878 | .790 | .827 | .710 | .250 | .910 | .902 | .000 | .828 | .000 | .881 | .856 | .923 | .926 | .250 | .923 | .925 |

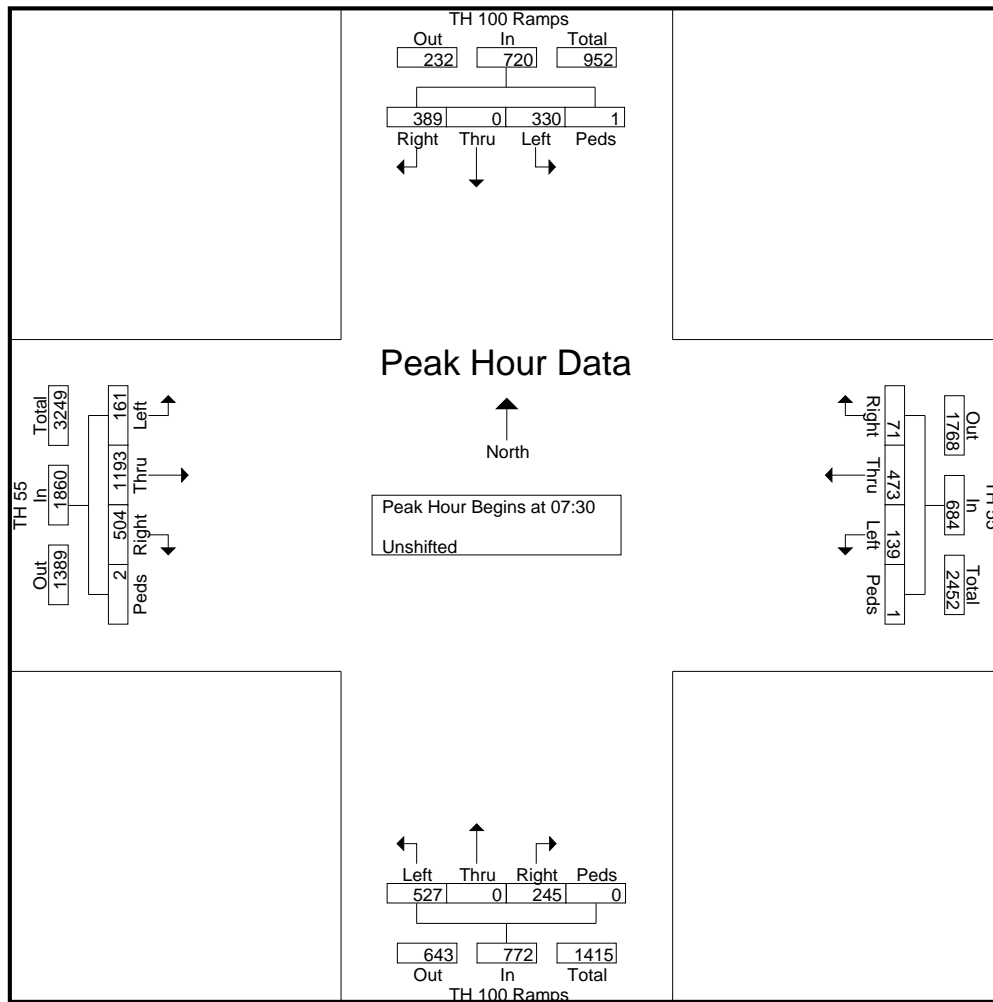



MINNESOTA DEPT OF TRANSPORTATION

TRAFFIC DATA COLLECTION - METRO

File Name : TH 55 @ TH 100 RAMPS 2006
 Site Code : 08032812
 Start Date : 8/3/2006
 Page No : 4

| Start Time | TH 100 Ramps Southbound | | | | | TH 55 Westbound | | | | | TH 100 Ramps Northbound | | | | | TH 55 Eastbound | | | | | Int. Total |
|--------------|-------------------------|------|-------|------|------------|-----------------|------|-------|------|------------|-------------------------|------|-------|------|------------|-----------------|------|-------|------|------------|------------|
| | Left | Thru | Right | Peds | App. Total | Left | Thru | Right | Peds | App. Total | Left | Thru | Right | Peds | App. Total | Left | Thru | Right | Peds | App. Total | |
| 12:00 | 21 | 0 | 47 | 0 | 68 | 58 | 125 | 46 | 0 | 229 | 95 | 0 | 32 | 0 | 127 | 34 | 118 | 112 | 0 | 264 | 688 |
| 12:15 | 28 | 0 | 59 | 0 | 87 | 62 | 86 | 20 | 0 | 168 | 110 | 0 | 46 | 0 | 156 | 54 | 106 | 112 | 0 | 272 | 683 |
| 12:30 | 22 | 0 | 54 | 0 | 76 | 71 | 125 | 28 | 0 | 224 | 92 | 0 | 48 | 0 | 140 | 32 | 122 | 124 | 0 | 278 | 718 |
| 12:45 | 32 | 0 | 47 | 0 | 79 | 72 | 90 | 25 | 0 | 187 | 110 | 0 | 51 | 0 | 161 | 52 | 108 | 113 | 0 | 273 | 700 |
| Total Volume | 103 | 0 | 207 | 0 | 310 | 263 | 426 | 119 | 0 | 808 | 407 | 0 | 177 | 0 | 584 | 172 | 454 | 461 | 0 | 1087 | 2789 |
| % App. Total | 33.2 | 0 | 66.8 | 0 | | 32.5 | 52.7 | 14.7 | 0 | | 69.7 | 0 | 30.3 | 0 | | 15.8 | 41.8 | 42.4 | 0 | | |
| PHF | .805 | .000 | .877 | .000 | .891 | .913 | .852 | .647 | .000 | .882 | .925 | .000 | .868 | .000 | .907 | .796 | .930 | .929 | .000 | .978 | .971 |

Peak Hour Analysis From 10:00 to 13:45 - Peak 1 of 1
 Peak Hour for Entire Intersection Begins at 12:00

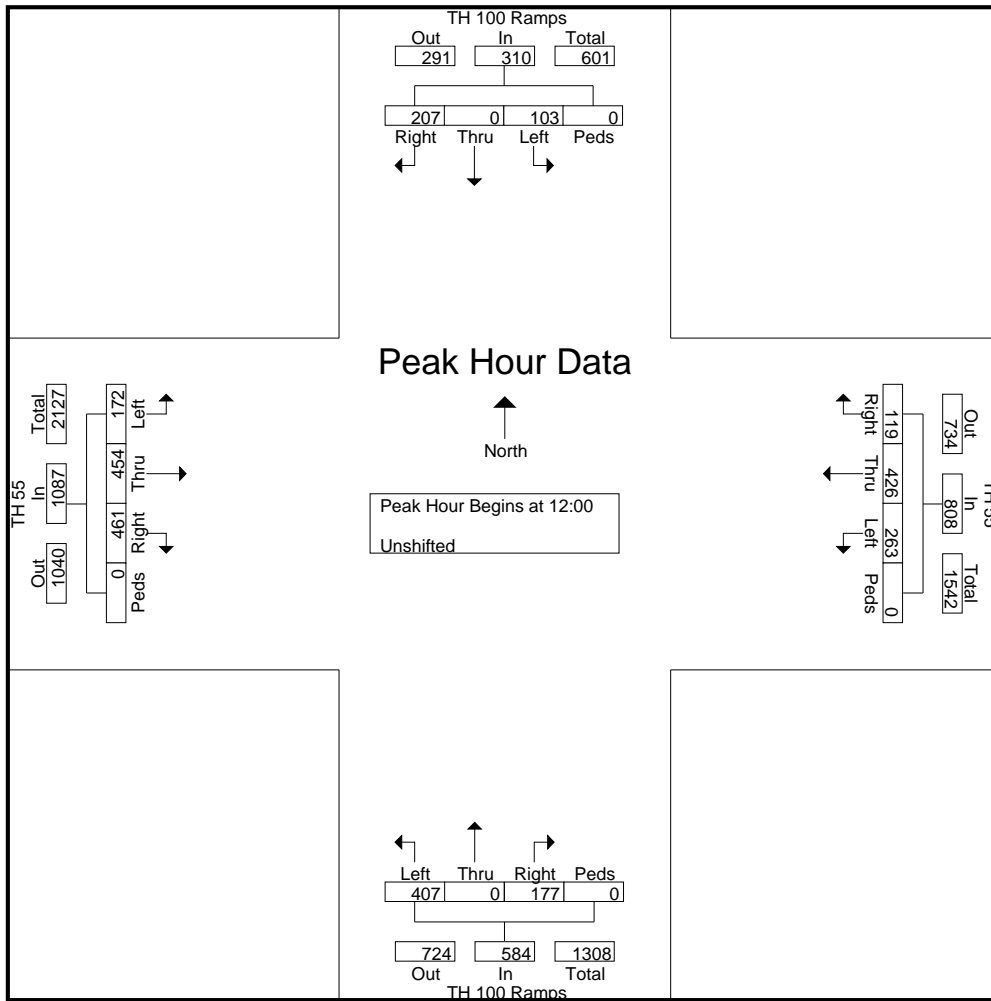



MINNESOTA DEPT OF TRANSPORTATION

TRAFFIC DATA COLLECTION - METRO

File Name : TH 55 @ TH 100 RAMPS 2006
 Site Code : 08032812
 Start Date : 8/3/2006
 Page No : 5

| Start Time | TH 100 Ramps Southbound | | | | | TH 55 Westbound | | | | | TH 100 Ramps Northbound | | | | | TH 55 Eastbound | | | | | Int. Total |
|--------------|-------------------------|------|-------|------|------------|-----------------|------|-------|------|------------|-------------------------|------|-------|------|------------|-----------------|------|-------|------|------------|------------|
| | Left | Thru | Right | Peds | App. Total | Left | Thru | Right | Peds | App. Total | Left | Thru | Right | Peds | App. Total | Left | Thru | Right | Peds | App. Total | |
| 16:30 | 30 | 0 | 51 | 0 | 81 | 84 | 176 | 55 | 0 | 315 | 109 | 3 | 53 | 0 | 165 | 107 | 116 | 177 | 0 | 400 | 961 |
| 16:45 | 44 | 0 | 80 | 0 | 124 | 62 | 178 | 42 | 0 | 282 | 104 | 0 | 55 | 0 | 159 | 131 | 131 | 171 | 0 | 433 | 998 |
| 17:00 | 26 | 0 | 48 | 1 | 75 | 85 | 180 | 70 | 0 | 335 | 113 | 0 | 42 | 0 | 155 | 89 | 116 | 201 | 0 | 406 | 971 |
| 17:15 | 36 | 0 | 64 | 0 | 100 | 81 | 185 | 72 | 0 | 338 | 94 | 0 | 50 | 0 | 144 | 116 | 116 | 189 | 0 | 421 | 1003 |
| Total Volume | 136 | 0 | 243 | 1 | 380 | 312 | 719 | 239 | 0 | 1270 | 420 | 3 | 200 | 0 | 623 | 443 | 479 | 738 | 0 | 1660 | 3933 |
| % App. Total | 35.8 | 0 | 63.9 | 0.3 | | 24.6 | 56.6 | 18.8 | 0 | | 67.4 | 0.5 | 32.1 | 0 | | 26.7 | 28.9 | 44.5 | 0 | | |
| PHF | .773 | .000 | .759 | .250 | .766 | .918 | .972 | .830 | .000 | .939 | .929 | .250 | .909 | .000 | .944 | .845 | .914 | .918 | .000 | .958 | .980 |

Peak Hour Analysis From 14:00 to 17:45 - Peak 1 of 1
 Peak Hour for Entire Intersection Begins at 16:30

