

Associated Consulting Services (ACS)
 Roseville, MN 55113
 -- TRAFFIC DATA --

MN-55 at Motel Entrance_2022
 City: Eagan
 Data Prepared By: ACS
 TURNING MOVEMENT COUNT

File Name : MN-55 at Motel Entrance_2022
 Site Code :
 Start Date : 9/28/2022
 Page No : 1

Groups Printed- Cars - Trucks

Start Time	MN-55 Southbound				Westbound				MN-55 Northbound				Motel Entrance Eastbound				Int. Total
	Left	Thru	Right	Peds	Left	Thru	Right	Peds	Left	Thru	Right	Peds	Left	Thru	Right	Peds	
06:00	0	54	0	0	0	0	0	0	0	80	0	0	1	0	0	0	135
06:15	0	64	0	0	0	0	0	0	0	110	0	0	0	0	0	0	174
06:30	0	98	0	0	0	0	0	0	0	136	0	0	0	0	0	0	234
06:45	0	125	1	0	0	0	0	0	0	173	0	0	1	0	0	0	300
Total	0	341	1	0	0	0	0	0	0	499	0	0	2	0	0	0	843
07:00	0	124	0	0	0	0	0	0	0	165	0	0	0	0	0	0	289
07:15	0	126	0	0	0	0	0	0	0	191	0	0	1	0	0	0	318
07:30	0	109	0	0	0	0	0	0	0	219	0	0	0	0	0	0	328
07:45	0	136	0	0	0	0	0	0	0	216	0	0	0	0	0	0	352
Total	0	495	0	0	0	0	0	0	0	791	0	0	1	0	0	0	1287
08:00	0	137	0	0	0	0	0	0	0	200	0	0	0	0	0	1	338
08:15	0	117	0	0	0	0	0	0	0	166	0	0	0	0	0	0	283
08:30	0	131	0	0	0	0	0	0	0	167	0	0	0	0	0	0	298
08:45	0	111	0	0	0	0	0	0	0	128	0	0	0	0	0	0	239
Total	0	496	0	0	0	0	0	0	0	661	0	0	0	0	0	1	1158
09:00	0	113	0	0	0	0	0	0	0	115	0	0	1	0	0	0	229
09:15	0	109	1	0	0	0	0	0	0	109	0	0	0	0	0	0	219
09:30	0	110	1	0	0	0	0	0	0	106	0	0	1	0	1	0	219
09:45	0	121	0	0	0	0	0	0	0	102	0	0	0	0	0	0	223
Total	0	453	2	0	0	0	0	0	0	432	0	0	2	0	1	0	890
10:00	0	105	0	0	0	0	0	0	0	103	0	0	0	0	0	0	208
10:15	0	102	0	0	0	0	0	0	0	95	0	0	0	0	0	0	197
10:30	0	89	0	0	0	0	0	0	0	102	0	0	1	0	0	0	192
10:45	0	113	0	0	0	0	0	0	0	95	0	0	0	0	0	0	208
Total	0	409	0	0	0	0	0	0	0	395	0	0	1	0	0	0	805
11:00	0	100	0	0	0	0	0	0	0	89	0	0	1	0	0	0	190
11:15	0	122	1	0	0	0	0	0	0	121	0	0	0	0	0	0	244
11:30	0	139	0	0	0	0	0	0	0	144	0	0	0	0	0	0	283
11:45	0	137	0	0	0	0	0	0	1	128	0	0	0	0	0	0	266
Total	0	498	1	0	0	0	0	0	1	482	0	0	1	0	0	0	983
12:00	0	139	0	0	0	0	0	0	0	105	0	0	1	0	0	0	245
12:15	0	144	2	0	0	0	0	0	0	110	0	0	1	0	0	0	257
12:30	0	123	0	0	0	0	0	0	1	104	0	0	0	0	2	0	230
12:45	0	151	0	0	0	0	0	0	0	90	0	0	0	0	0	1	242
Total	0	557	2	0	0	0	0	0	1	409	0	0	2	0	2	1	974
13:00	0	130	1	0	0	0	0	0	0	106	0	0	0	0	2	0	239
13:15	0	134	1	0	0	0	0	0	1	104	0	0	0	0	0	0	240
13:30	0	132	0	0	0	0	0	0	0	102	0	0	0	0	0	0	234
13:45	0	141	0	0	0	0	0	0	0	117	0	0	0	0	0	3	261
Total	0	537	2	0	0	0	0	0	1	429	0	0	0	0	2	3	974
14:00	0	125	0	0	0	0	0	0	0	124	0	0	1	0	0	0	250
14:15	0	141	0	0	0	0	0	0	0	90	0	0	0	0	0	0	231
14:30	0	199	1	0	0	0	0	0	0	138	0	0	0	0	0	0	338

Associated Consulting Services (ACS)
 Roseville, MN 55113
 -- TRAFFIC DATA --

MN-55 at Motel Entrance_2022
 City: Eagan
 Data Prepared By: ACS
 TURNING MOVEMENT COUNT

File Name : MN-55 at Motel Entrance_2022
 Site Code :
 Start Date : 9/28/2022
 Page No : 2

Groups Printed- Cars - Trucks

Start Time	MN-55 Southbound				Westbound				MN-55 Northbound				Motel Entrance Eastbound				Int. Total	
	Left	Thru	Right	Peds	Left	Thru	Right	Peds	Left	Thru	Right	Peds	Left	Thru	Right	Peds		
14:45	0	192	0	0	0	0	0	0	0	132	0	0	0	0	0	0	0	324
Total	0	657	1	0	0	0	0	0	0	484	0	0	1	0	0	0	0	1143
15:00	0	203	0	0	0	0	0	0	0	123	0	0	0	0	0	0	0	326
15:15	0	156	0	0	0	0	0	0	0	145	0	0	0	0	0	0	1	302
15:30	0	219	0	0	0	0	0	0	0	152	0	0	0	0	0	0	5	376
15:45	0	190	0	0	0	0	0	0	0	131	0	0	1	0	0	0	0	322
Total	0	768	0	0	0	0	0	0	0	551	0	0	1	0	0	6	0	1326
16:00	0	236	0	0	0	0	0	0	0	139	0	0	0	0	0	0	0	375
16:15	0	219	0	0	0	0	0	0	0	148	0	0	0	0	0	0	0	367
16:30	0	217	0	1	0	0	0	0	0	143	0	0	0	0	0	0	1	362
16:45	0	220	0	0	0	0	0	0	1	142	0	0	0	0	0	0	0	363
Total	0	892	0	1	0	0	0	0	1	572	0	0	0	0	0	1	0	1467
17:00	0	193	3	0	0	0	0	0	0	153	0	0	0	0	0	0	0	349
17:15	0	195	0	0	0	0	0	0	0	149	0	0	1	0	0	0	0	345
17:30	0	178	0	0	0	0	0	0	0	119	0	0	2	0	1	0	0	300
17:45	0	146	2	0	0	0	0	0	0	116	0	0	0	0	0	0	0	264
Total	0	712	5	0	0	0	0	0	0	537	0	0	3	0	1	0	0	1258
Grand Total	0	6815	14	1	0	0	0	0	4	6242	0	0	14	0	6	12	0	13108
Apprch %	0	99.8	0.2	0	0	0	0	0	0.1	99.9	0	0	43.8	0	18.8	37.5	0	
Total %	0	52	0.1	0	0	0	0	0	0	47.6	0	0	0.1	0	0	0.1	0	
Cars	0	6106	14	1	0	0	0	0	3	5643	0	0	14	0	5	12	0	11798
% Cars	0	89.6	100	100	0	0	0	0	75	90.4	0	0	100	0	83.3	100	0	90
Trucks	0	709	0	0	0	0	0	0	1	599	0	0	0	0	1	0	0	1310
% Trucks	0	10.4	0	0	0	0	0	0	25	9.6	0	0	0	0	16.7	0	0	10

Associated Consulting Services (ACS)
 Roseville, MN 55113
 -- TRAFFIC DATA --

MN-55 at Motel Entrance_2022
 City: Eagan
 Data Prepared By: ACS
 TURNING MOVEMENT COUNT

File Name : MN-55 at Motel Entrance_2022
 Site Code :
 Start Date : 9/28/2022
 Page No : 3

Start Time	MN-55 Southbound					Westbound					MN-55 Northbound					Motel Entrance Eastbound					Int. Total
	Left	Thru	Right	Peds	App. Total	Left	Thru	Right	Peds	App. Total	Left	Thru	Right	Peds	App. Total	Left	Thru	Right	Peds	App. Total	
Peak Hour Analysis From 06:00 to 11:45 - Peak 1 of 1																					
Peak Hour for Entire Intersection Begins at 07:15																					
07:15	0	126	0	0	126	0	0	0	0	0	0	191	0	0	191	1	0	0	0	1	318
07:30	0	109	0	0	109	0	0	0	0	0	0	219	0	0	219	0	0	0	0	0	328
07:45	0	136	0	0	136	0	0	0	0	0	0	216	0	0	216	0	0	0	0	0	352
08:00	0	137	0	0	137	0	0	0	0	0	0	200	0	0	200	0	0	0	1	1	338
Total Volume	0	508	0	0	508	0	0	0	0	0	0	826	0	0	826	1	0	0	1	2	1336
% App. Total	0	100	0	0		0	0	0	0		0	100	0	0		50	0	0	50		
PHF	.000	.927	.000	.000	.927	.000	.000	.000	.000	.000	.000	.943	.000	.000	.943	.250	.000	.000	.250	.500	.949

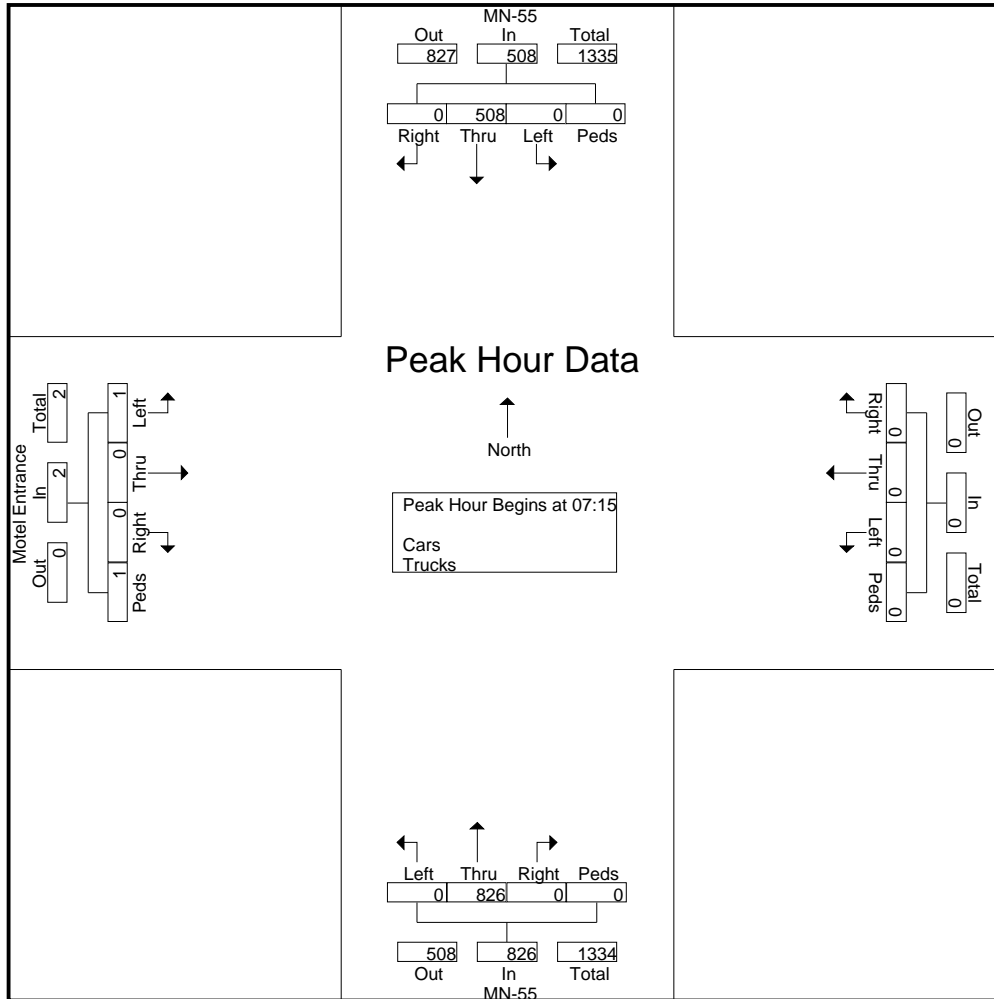

Associated Consulting Services (ACS)
 Roseville, MN 55113
 -- TRAFFIC DATA --

MN-55 at Motel Entrance_2022
 City: Eagan
 Data Prepared By: ACS
 TURNING MOVEMENT COUNT

File Name : MN-55 at Motel Entrance_2022
 Site Code :
 Start Date : 9/28/2022
 Page No : 4

Start Time	MN-55 Southbound					Westbound					MN-55 Northbound					Motel Entrance Eastbound					Int. Total
	Left	Thru	Right	Peds	App. Total	Left	Thru	Right	Peds	App. Total	Left	Thru	Right	Peds	App. Total	Left	Thru	Right	Peds	App. Total	
Peak Hour Analysis From 12:00 to 17:45 - Peak 1 of 1																					
Peak Hour for Entire Intersection Begins at 16:00																					
16:00	0	236	0	0	236	0	0	0	0	0	0	139	0	0	139	0	0	0	0	0	375
16:15	0	219	0	0	219	0	0	0	0	0	0	148	0	0	148	0	0	0	0	0	367
16:30	0	217	0	1	218	0	0	0	0	0	0	143	0	0	143	0	0	0	1	1	362
16:45	0	220	0	0	220	0	0	0	0	0	1	142	0	0	143	0	0	0	0	0	363
Total Volume	0	892	0	1	893	0	0	0	0	0	1	572	0	0	573	0	0	0	1	1	1467
% App. Total	0	99.9	0	0.1		0	0	0	0		0.2	99.8	0	0		0	0	0	100		
PHF	.000	.945	.000	.250	.946	.000	.000	.000	.000	.000	.250	.966	.000	.000	.968	.000	.000	.000	.250	.250	.978

