



# MINNESOTA DEPT OF TRANSPORTATION

## TRAFFIC DATA COLLECTION - METRO

TH-61 AT 4TH ST., WHITE BEAR LAKE  
 REF.PT.: 147.244  
 JAMAR # 631 RE  
 TURN MOVEMENT COUNT

File Name : TH-61 AT 4TH ST WBL 2007  
 Site Code : 00000000  
 Start Date : 9/6/2007  
 Page No : 1

**Groups Printed- Cars & Trucks**

Start Time	TH-61 Southbound				4TH ST. Westbound				TH-61 Northbound				4TH ST. Eastbound				Int. Total
	Left	Thru	Right	Peds	Left	Thru	Right	Peds	Left	Thru	Right	Peds	Left	Thru	Right	Peds	
06:00	4	65	9	0	9	1	21	0	1	226	9	0	18	1	0	0	364
06:15	7	87	2	0	10	0	21	0	0	300	16	0	19	2	0	1	465
06:30	12	72	11	0	7	2	25	0	0	342	13	0	15	5	3	0	507
06:45	24	117	5	0	16	6	38	1	1	374	17	0	27	9	0	0	635
<b>Total</b>	<b>47</b>	<b>341</b>	<b>27</b>	<b>0</b>	<b>42</b>	<b>9</b>	<b>105</b>	<b>1</b>	<b>2</b>	<b>1242</b>	<b>55</b>	<b>0</b>	<b>79</b>	<b>17</b>	<b>3</b>	<b>1</b>	<b>1971</b>
07:00	21	128	6	1	14	7	62	0	0	437	25	0	31	6	0	5	743
07:15	32	130	16	0	15	5	50	3	0	363	34	0	33	12	0	0	693
07:30	30	138	7	2	29	4	25	2	1	402	15	0	21	8	0	1	685
07:45	33	144	5	0	27	15	24	1	8	307	23	0	25	19	0	0	631
<b>Total</b>	<b>116</b>	<b>540</b>	<b>34</b>	<b>3</b>	<b>85</b>	<b>31</b>	<b>161</b>	<b>6</b>	<b>9</b>	<b>1509</b>	<b>97</b>	<b>0</b>	<b>110</b>	<b>45</b>	<b>0</b>	<b>6</b>	<b>2752</b>
08:00	29	137	4	0	16	4	40	4	15	271	25	1	32	21	1	1	601
08:15	19	127	8	0	24	14	44	1	3	240	22	0	24	10	1	2	539
08:30	30	150	18	1	30	18	33	0	1	221	12	0	45	7	0	3	569
08:45	25	167	23	0	27	14	36	0	1	211	24	0	28	15	2	0	573
<b>Total</b>	<b>103</b>	<b>581</b>	<b>53</b>	<b>1</b>	<b>97</b>	<b>50</b>	<b>153</b>	<b>5</b>	<b>20</b>	<b>943</b>	<b>83</b>	<b>1</b>	<b>129</b>	<b>53</b>	<b>4</b>	<b>6</b>	<b>2282</b>
*** BREAK ***																	
14:30	45	236	17	0	22	15	36	5	4	172	13	0	42	19	6	0	632
14:45	59	308	27	0	33	12	46	5	5	152	19	8	45	23	2	1	745
<b>Total</b>	<b>104</b>	<b>544</b>	<b>44</b>	<b>0</b>	<b>55</b>	<b>27</b>	<b>82</b>	<b>10</b>	<b>9</b>	<b>324</b>	<b>32</b>	<b>8</b>	<b>87</b>	<b>42</b>	<b>8</b>	<b>1</b>	<b>1377</b>
15:00	53	308	25	0	35	22	38	4	4	173	18	0	43	17	5	5	750
15:15	55	281	29	0	27	21	38	7	4	160	24	0	28	25	1	2	702
15:30	48	342	27	0	28	23	40	0	3	137	19	0	38	17	4	4	730
15:45	51	375	33	1	39	24	36	5	1	145	18	2	31	26	5	2	794
<b>Total</b>	<b>207</b>	<b>1306</b>	<b>114</b>	<b>1</b>	<b>129</b>	<b>90</b>	<b>152</b>	<b>16</b>	<b>12</b>	<b>615</b>	<b>79</b>	<b>2</b>	<b>140</b>	<b>85</b>	<b>15</b>	<b>13</b>	<b>2976</b>
16:00	62	343	17	1	38	24	40	0	1	162	20	0	38	19	3	5	773
16:15	37	365	23	3	32	20	43	3	7	193	24	0	33	32	4	0	819
16:30	40	389	32	1	45	22	32	6	1	186	14	0	34	22	3	0	827
16:45	60	400	33	1	44	18	40	5	6	177	15	0	35	32	7	5	878
<b>Total</b>	<b>199</b>	<b>1497</b>	<b>105</b>	<b>6</b>	<b>159</b>	<b>84</b>	<b>155</b>	<b>14</b>	<b>15</b>	<b>718</b>	<b>73</b>	<b>0</b>	<b>140</b>	<b>105</b>	<b>17</b>	<b>10</b>	<b>3297</b>
17:00	54	397	20	1	32	24	39	1	4	182	20	0	35	37	6	12	864
17:15	56	412	24	1	35	14	41	0	2	173	23	0	41	22	9	2	855
17:30	55	346	32	3	39	21	42	3	4	178	14	0	35	34	5	4	815
17:45	37	356	16	2	46	24	40	3	6	148	12	0	28	15	6	2	741
<b>Total</b>	<b>202</b>	<b>1511</b>	<b>92</b>	<b>7</b>	<b>152</b>	<b>83</b>	<b>162</b>	<b>7</b>	<b>16</b>	<b>681</b>	<b>69</b>	<b>0</b>	<b>139</b>	<b>108</b>	<b>26</b>	<b>20</b>	<b>3275</b>
<b>Grand Total</b>	<b>978</b>	<b>6320</b>	<b>469</b>	<b>18</b>	<b>719</b>	<b>374</b>	<b>970</b>	<b>59</b>	<b>83</b>	<b>6032</b>	<b>488</b>	<b>11</b>	<b>824</b>	<b>455</b>	<b>73</b>	<b>57</b>	<b>17930</b>
Apprch %	12.6	81.2	6	0.2	33.9	17.6	45.7	2.8	1.3	91.2	7.4	0.2	58.5	32.3	5.2	4	
Total %	5.5	35.2	2.6	0.1	4	2.1	5.4	0.3	0.5	33.6	2.7	0.1	4.6	2.5	0.4	0.3	



# MINNESOTA DEPT OF TRANSPORTATION

## TRAFFIC DATA COLLECTION - METRO

TH-61 AT 4TH ST., WHITE BEAR LAKE  
 REF.PT.: 147.244  
 JAMAR # 631 RE  
 TURN MOVEMENT COUNT

File Name : TH-61 AT 4TH ST WBL 2007  
 Site Code : 00000000  
 Start Date : 9/6/2007  
 Page No : 2

Start Time	TH-61 Southbound					4TH ST. Westbound					TH-61 Northbound					4TH ST. Eastbound					Int. Total
	Left	Thru	Right	Peds	App. Total	Left	Thru	Right	Peds	App. Total	Left	Thru	Right	Peds	App. Total	Left	Thru	Right	Peds	App. Total	
Peak Hour Analysis From 06:00 to 08:45 - Peak 1 of 1																					
Peak Hour for Entire Intersection Begins at 06:45																					
06:45	24	117	5	0	146	16	6	38	1	61	1	374	17	0	392	27	9	0	0	36	635
07:00	21	128	6	1	156	14	7	62	0	83	0	437	25	0	462	31	6	0	5	42	743
07:15	32	130	16	0	178	15	5	50	3	73	0	363	34	0	397	33	12	0	0	45	693
07:30	30	138	7	2	177	29	4	25	2	60	1	402	15	0	418	21	8	0	1	30	685
Total Volume	107	513	34	3	657	74	22	175	6	277	2	1576	91	0	1669	112	35	0	6	153	2756
% App. Total	16.3	78.1	5.2	0.5		26.7	7.9	63.2	2.2		0.1	94.4	5.5	0		73.2	22.9	0	3.9		
PHF	.836	.929	.531	.375	.923	.638	.786	.706	.500	.834	.500	.902	.669	.000	.903	.848	.729	.000	.300	.850	.927

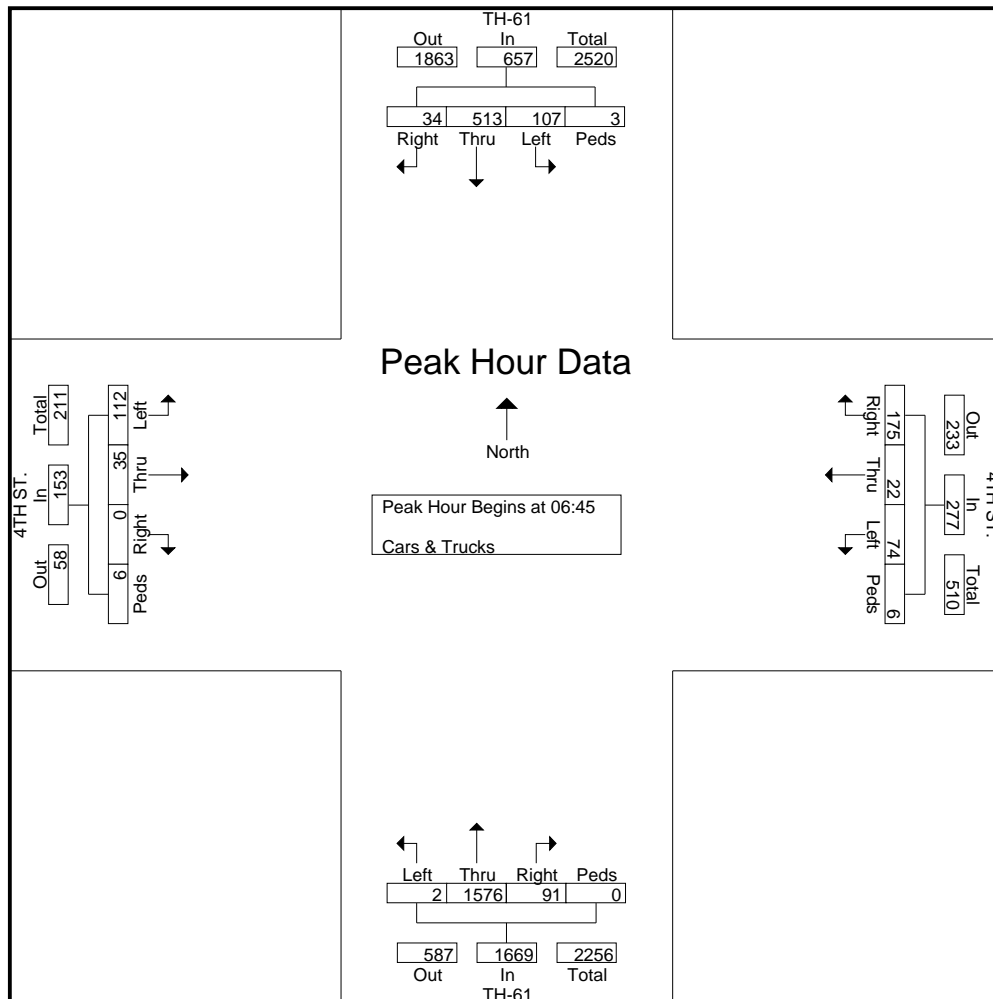



# MINNESOTA DEPT OF TRANSPORTATION

## TRAFFIC DATA COLLECTION - METRO

TH-61 AT 4TH ST., WHITE BEAR LAKE  
 REF.PT.: 147.244  
 JAMAR # 631 RE  
 TURN MOVEMENT COUNT

File Name : TH-61 AT 4TH ST WBL 2007  
 Site Code : 00000000  
 Start Date : 9/6/2007  
 Page No : 3

Start Time	TH-61 Southbound					4TH ST. Westbound					TH-61 Northbound					4TH ST. Eastbound					Int. Total
	Left	Thru	Right	Peds	App. Total	Left	Thru	Right	Peds	App. Total	Left	Thru	Right	Peds	App. Total	Left	Thru	Right	Peds	App. Total	
Peak Hour Analysis From 14:30 to 17:45 - Peak 1 of 1																					
Peak Hour for Entire Intersection Begins at 16:30																					
16:30	40	389	32	1	462	45	22	32	6	105	1	186	14	0	201	34	22	3	0	59	827
16:45	60	400	33	1	494	44	18	40	5	107	6	177	15	0	198	35	32	7	5	79	878
17:00	54	397	20	1	472	32	24	39	1	96	4	182	20	0	206	35	37	6	12	90	864
17:15	56	412	24	1	493	35	14	41	0	90	2	173	23	0	198	41	22	9	2	74	855
Total Volume	210	1598	109	4	1921	156	78	152	12	398	13	718	72	0	803	145	113	25	19	302	3424
% App. Total	10.9	83.2	5.7	0.2		39.2	19.6	38.2	3		1.6	89.4	9	0		48	37.4	8.3	6.3		
PHF	.875	.970	.826	1.000	.972	.867	.813	.927	.500	.930	.542	.965	.783	.000	.975	.884	.764	.694	.396	.839	.975

